

Digital Temperature Controller
FY400/600/700/800/900
FA230/231

Operation Manual

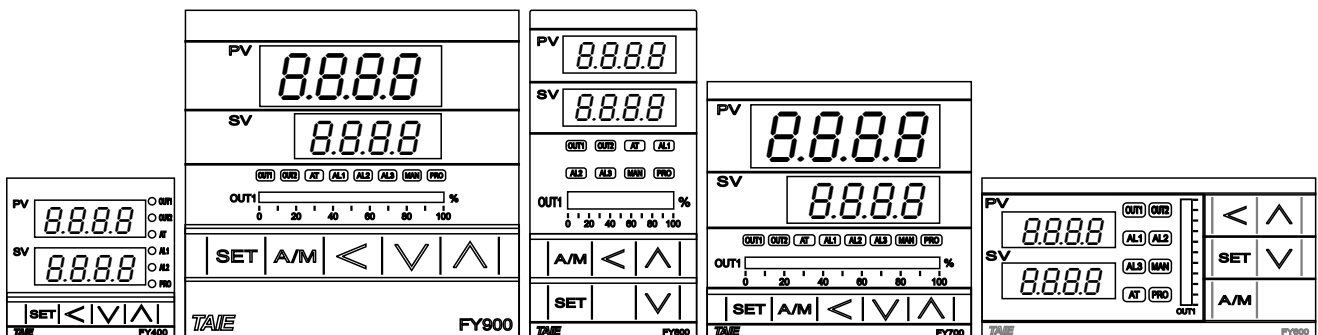

Ver 1.7



台灣儀控股份有限公司
TAIWAN INSTRUMENT & CONTROL CO., LTD

Preface

Thank you for purchasing the TAIE FY/FA series digital temperature controllers.

This User's Manual contains instructions for mounting, functions, operations and notes when operating the FY/FA series digital temperature controllers.

To prevent accidents arising from the misuse of this controller, please ensure the operator receives this manual.

Notes

- This instrument should be used in accordance with the specifications described in the manual. If it is not used according to the specifications, it may malfunction or cause a fire.
- Be sure to follow the warnings, cautions and notices. If they are not observed, serious injury or malfunction may occur.
- The contents of this instruction manual are subject to change without notice.
- Care has been taken to ensure that the contents of this instruction manual are correct, but if there are any doubts, mistakes or questions, please inform our company.
- Measures must be taken to ensure that the operator cannot touch power terminals or other high voltage sections.
- Any unauthorized transfer or copying of this document, in part or in whole, is prohibited.
- TAIWAN INSTRUMENT & CONTROL Co., Ltd. is not liable for any damage or secondary damage(s) incurred as a result of using this product, including any indirect damage.

Copyright and Trademark

TAIWAN INSTRUMENT & CONTROL Co., Ltd. owns the copyright of this manual.

- Reproduction of this manual without express permission from TAIWAN INSTRUMENT & CONTROL Co., Ltd. is prohibited.
- Modbus protocol is a communication protocol that Modicon Inc. Developed for PLC and Modbus is a registered trademark of Schneider Electric.
- Other company names and the product names are the trademarks or registered trademarks of each company.



WARNING : This mark indicates precautions that must be taken if there is danger of electric shock, fire, etc., which could result in loss of life or injury.



CAUTION : This mark indicates that if these precautions and operating procedures are not taken, damage to the instrument may result.



WARNING

- An external protection device must be installed if failure of this instrument could result in damage to the instrument, equipment or injury to personnel.
- All wiring must be completed before power is turned on to prevent electric shock, fire or damage to instrument and equipment.
- This instrument must be used in accordance with the specifications to prevent fire or damage to instrument and equipment.
- This instrument is not intended for use in locations subject to flammable or explosive gases.
- Do not touch high-voltage connections such as power supply terminals, etc. to avoid electric shock.
- TAIWAN INSTRUMENT & CONTROL Co., Ltd. is not responsible if this instrument is repaired, modified or disassembled by other than factory-approved personnel. Malfunction can occur and warranty is void under these conditions.

CAUTION

- This product is intended for use with industrial machines, test and measuring equipment. It is not designed for use with medical equipment and nuclear energy.
- This is a Class A instrument. In a domestic environment, this instrument may cause radio interference, in which case the user may be required to take additional measures.
- This instrument is protected from electric shock by reinforced insulation.
Provide reinforced insulation between the wire for the input signal and the wires for instrument power supply, source of power and loads.
- This instrument is designed for installation in an enclosed instrumentation panel. All high-voltage connections such as power supply terminals must be enclosed in the instrumentation panel to avoid electric shock by operating personnel.
- All precautions described in this manual should be taken to avoid damage to the instrument or equipment.
- All wiring must be completed before power is turned on to prevent electric shock, instrument failure, or incorrect action.
- The power must be turned off before repairing work for input break and output failure including replacement of sensor, contactor or SSR, and all wiring must be completed before power is turned on again.
- Prevent metal fragments or lead wire scraps from falling inside instrument case to avoid electric shock, fire or malfunction.

- Please use crimp terminals suitable for M3 screws, as shown below:

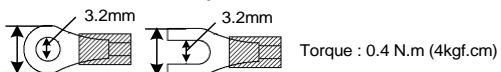

- Tighten each terminal screw to the specified torque found in the manual to avoid electric shock, fire or malfunction.
- When the thermocouple wiring is extended, please use the compensation lead of the corresponding type to this thermocouple.

Content

1.	Order Information	7
1.1	FY Order Information	7
1.2	FA Order Information	7
2.	Specifications	8
2.1	FY Specifications	8
2.2	FA Specifications	9
3.	Input Range Table	10
4.	Packing List & Label Information	10
4.1	Packing List Guide	10
4.2	Label Guide	11
4.2.1	FY400	11
4.2.2	FY700	11
4.2.3	FY600/800/900	12
4.2.4	FA230	12
4.2.5	FA231	13
5.	Parts Description	14
5.1	FY Series	14
5.2	FA Series	15
6.	Installation	16
6.1	FY400 Dimensions	16
6.2	FY600 Dimensions	16
6.3	FY700 Dimensions	16
6.4	FY800 Dimensions	17
6.5	FY900 Dimensions	17
6.6	FA230/231 Dimensions	18
7.	Terminal Arrangement	19
7.1	FY400 Terminal Arrangement	19
7.2	FY600 Terminal Arrangement	20
7.3	FY700 Terminal Arrangement	21
7.4	FY800 Terminal Arrangement	22
7.5	FY900 Terminal Arrangement	23
7.6	FA230 Terminal Arrangement	24
7.7	FA231 Terminal Arrangement	25
8.	Basic Function Setting	26
8.1	Changing Input Type	26
8.2	SV Setting	26
8.3	Setting PID Values Automatically(Auto-tuning)	26
8.4	Setting PID Values Manually	26
8.5	Controlling With ON/OFF Action	27
8.6	Alarm Mode Setting	27
8.7	Alarm Value Setting	27

8.8	Controlling With Manual Control.....	28
9.	Flow Chart of Parameter Setting.....	28
9.1	Level Operation Mode	28
9.2	Level Operation Diagram	29
9.3	Data Lock Function	29
9.4	Level 1 (User Level) All Parameters Display	30
9.5	LEVEL_1 Parameter	31
9.6	Level 2 (PID Level) All Parameters Display	32
9.7	LEVEL_2 Parameter	33
9.8	Level 3 (Input Level) All Parameters Display	34
9.9	LEVEL_3 Parameter	34
9.10	Level 4 (Setting Level) All Parameters Display	37
9.11	LEVEL_4 Parameter.....	37
9.12	Parameters Hide/Display Table on Level 4	38
9.13	Fast Level All Parameters Display	40
9.14	Fast Level Parameter	40
10.	Functional Descriptions.....	43
10.1	PV bias	43
10.2	Retransmission.....	44
10.3	Remote SV	45
10.4	Heater Break Alarm	47
10.5	Dehumidification Function	49
10.6	Motor Valve Control	50
10.7	RAMP & SOAK.....	53
10.8	Proportional Control	56
10.9	Master-Slave communication	57
10.10	Piece Linear Compensation	58
10.11	Auto-tuning and Startup tuning.....	61
10.12	ON / OFF Control	64
10.13	Super SV	66
10.14	Input Math Function.....	67
11.	Alarm Action	70
11.1	Alarm Mode	71
11.2	Alarm Special Setting	73
11.3	Alarm Example	73
12.	Programmable.....	74
12.1	Parameter.....	74
12.2	Key Operation Description	75
12.3	Program Initial Setting	76
12.4	Create Program.....	78
12.5	Program Execution Flow	81
12.6	Program Setting Example	81
13.	Modification of Output Module	82

13.1	Relay Control (1a)	82
13.2	Relay Control (1c)	82
13.3	SSR Control	82
13.4	Linear Control	82
13.5	Output Calibration Procedure Diagram	83
13.6	Output Calibration Steps	84
14.	Modification of Input Signal	85
14.1	Input modify to thermocouple	85
14.2	Input modify to RTD	86
14.3	Input modify to Linear (4~20mA)	87
14.4	Steps For Linear Input Calibration	87
15.	Phase angle / Zero cross Control	89
16.	Error Message	93
17.	Calibration parameters and experience value list	94
18.	FY/FA Communication Register Address Table	95
19.	FY/FA Fast Communication Register Address Table	96
20.	Program Design Table	97
21.	Glossary of Characters Used In This Manual	99

1. Order Information

1.1 FY Order Information

Model	Output 1	Output 2	Alarm	TRS	Remote	Communication	Input type	Power	Accessories
FY900(Red/Green light) FY901(Blue/White light) PFY900(Program)	1	0	1	0	0	0	0 1	A	N
FY400 48x48mm FY600 96x48mm FY700 72x72mm FY800 48x96mm FY900 96x96mm	0 None 1 Relay 2 Voltage Pulse (SSR Drive) 3 4~20mA 4 0~20mA A 0~5V B 0~10V C 1~5V D 2~10V	0 None 1 Relay 2 Voltage Pulse (SSR Drive) 3 4~20mA 4 0~20mA A 0~5V B 0~10V C 1~5V D 2~10V	0 None 1 1 Set 2 2 Sets 3 3 Sets A HBA B HBA+AL2 C HBA+AL2+AL3	0 None 1 4~20mA 2 0~20mA A 0~5V B 0~10V C 1~5V D 2~10V	0 None 1 4~20mA 2 0~20mA A 0~5V B 0~10V C 1~5V D 2~10V M Motor valve control feedback	0 None 3 TTL B RS-485	See input Range type code	A AC 85~265V D DC 24V	N None T Terminal Cover W IP65 R Terminal Cover +IP65
PFY400 / 401 48x48mm PFY600 96x48mm PFY700 / 701 72x72mm PFY800 / 801 48x96mm PFY900 / 901 96x96mm	5 1φSCR zero cross control 6 3φSCR zero cross control 7 Motor valve control 8 1φSCR phase angle control								

※ Block means optional functions with additional charge
 ※ HBA : Heater Break Alarm(HBA must use AL1 as alarm relay)

※ Block means optional functions with additional charge.

1.2 FA Order Information

Model	Output 1	Output 2	Alarm	TRS	Remote	Communication	Input type	Power
FA230(plug-in-out terminal) FA231(fixed terminal)	1	0	1	0	0	0	0 1	A
PFA230 PFA231	0 None 1 Relay 2 Voltage Pulse (SSR Drive) 3 4~20mA 4 0~20mA A 0~5V B 0~10V C 1~5V D 2~10V	0 None 1 Relay 2 Voltage Pulse (SSR Drive) 3 4~20mA 4 0~20mA A 0~5V B 0~10V C 1~5V D 2~10V	0 None 1 1 Set 2 2 Set A HBA B HBA+AL2	0 None 1 4~20mA 2 0~20mA A 0~5V B 0~10V C 1~5V D 2~10V	0 None 1 4~20mA 2 0~20mA A 0~5V B 0~10V C 1~5V D 2~10V	0 None 3 TTL B RS-485	See input Range type code	A AC 85~265V D DC 24V
	7 Motor valve control							

※ Block means optional functions with additional charge
 ※ HBA : Heater Break Alarm(HBA must use AL1 as alarm relay)

※ Block means optional functions with additional charge.

2. Specifications

2.1 FY Specifications

Model	FY400	FY600	FY700	FY800	FY900
Supply Voltage	AC 85 ~ 265V, DC 24V (Optional Functions)				
Power Frequency	50/60 Hz				
Power Consumption	Approximately 6VA				
Memory	Non-Volatile Memory EEPROM				
Sensor Input ※ Please refer to Input Range Table	Cold junction compensation device external Accuracy : 0.1%				
	Cold junction compensation device internal Accuracy : 0.3%				
	Sample time : 50ms				
	Thermocouple : (K, J, R, S, B, E, N, T, W, PL II, L)				
	RTD: PT100				
DC Linear Analog Input : 0~20mA, 4~20mA 0~1V, 0~5V, 0~10V, 0~2V, 1~5V, 2~10V 0~25mV, 0~50mV, 0~70mV					
Output	1a	1c	1c	1c	1c
	OUT1 Relay	1a SPST-NO, 250 VAC, 5A (resistive load), electrical life: 100,000 operations 1c SPDT-NO, 250 VAC, 5A (resistive load), electrical life: 50,000 operations SPDT-NC, 250 VAC, 2A (resistive load), electrical life: 20,000 operations			
	OUT2 Relay	SPST-NO, 250 VAC, 5A (resistive load), electrical life: 100,000 operations			
	SSR Driver	ON: 24 V OFF: 0V max. load current: 20mA, with short circuit protection circuit			
linear	4~20mA, 0~20mA, 0~5V, 0~10V, 1~5V, 2~10V				
Control Method	ON-OFF or P, PI, PID control				
Alarm	1a	1c	1a	1c	1c
	Alarm 1	1a SPST-NO, 250 VAC, 5A (resistive load), electrical life: 100,000 operations 1c SPDT-NO, 250 VAC, 5A (resistive load), electrical life: 50,000 operations SPDT-NC, 250 VAC, 2A (resistive load), electrical life: 20,000 operations			
	Alarm 2	SPST-NO, 250 VAC, 5A (resistive load), electrical life: 100,000 operations			
Alarm 3	---	1a	1a	1a	1a
SPST-NO, 250 VAC, 5A (resistive load), electrical life: 100,000 operations					
TRS	Re-transmitted Signal	4~20mA, 0~20mA, 0~5V, 0~10V, 1~5V, 2~10V			
	Source of Re-transmission	SV, PV			
	Accuracy	0.1%			
	Resolution	14 bit			
Remote SV	Signal	4~20mA, 0~20mA, 0~5V, 0~10V, 1~5V, 2~10V			
	Resolution	18 bit			
	controlled by	SV			
Motor valve	Signal	1KΩ, 560Ω			
	Resolution	18 bit			
	Controlled by	PV2			
Communication	Interface	RS-485 Half duplex Communication MAX. 31 units, MAX. distance 1200 meters			
	Protocol	Modbus RTU, TAIE			
	Parity bit	NONE, ODD, EVEN			
	Data bit	8 bit			
	Stop bit	1 or 2 bit			
	Baud rate	2400,4800,9600,19200,38400,57600,115200 bps			
Malfunction vibration	10~55 Hz 20m / s ² , for 10 min each in X, Y and Z directions.				
Vibration resistance	10~55 Hz 20m / s ² , for 2 hr each in X, Y and Z directions.				
Malfunction shock	100m / s ² , 3 times each in X, Y and Z directions.				
Shock resistance	300m / s ² , 3 times each in X, Y and Z directions.				
Operating Environment Temperature/Humidity	0 ~ 50°C (in the case of no freezing or condensation) / 20% ~ 90% RH				
Storage Environment Temperature	-25 ~ 65°C (in the case of no freezing or condensation)				
Dimension (mm)	W48 x H48 x D95	W96 x H48 x D95	W72 x H72 x D95	W48 x H96 x D95	W96 x H96 x D95
Weight	Approx.120g	Approx.170g	Approx.150g	Approx.170g	Approx.230g

2.2 FA Specifications

Model		FA231	FA230
Terminal		Fixed	Pluggable
Supply Voltage		AC 85 ~ 265V, DC 24V (Optional Functions)	
Power Frequency		50/60 Hz	
Power Consumption		Approximately 6VA	
Memory		Non-Volatile Memory EEPROM	
Sensor Input ※ Please refer to Input Range Table		Accuracy : 0.2%	
		Sample time : 50ms	
		Thermocouple : (K, J, R, S, B, E, N, T, W, PL II, L)	
		RTD : PT100	
		DC Linear Analog Input : 0~20mA, 4~20Ma 0~1V, 0~5V, 0~10V, 0~2V, 1~5V, 2~10V 0~25mV, 0~50mV, 0~70mV	
Output	OUT1 Relay	1a	1c
		1a SPST-NO, 250 VAC, 5A (resistive load), electrical life: 100,000 operations 1c SPDT-NO, 250 VAC, 5A (resistive load), electrical life: 50,000 operations SPDT-NC, 250 VAC, 2A (resistive load), electrical life: 20,000 operations	
	OUT2 Relay	SPST-NO, 250 VAC, 5A (resistive load), electrical life: 100,000 operations	
	SSR Driver	ON: 24 V OFF: 0V max. load current: 20mA, with short circuit protection circuit	
	linear	4~20mA,0~20mA, 0~5V,0~10V, 1~5V,2~10V	
Control Method		ON-OFF or P, PI, PID control	
Alarm	Alarm 1	1a	1c
	Alarm 2	1a SPST-NO, 250 VAC, 5A (resistive load), electrical life: 100,000 operations 1c SPDT-NO, 250 VAC, 5A (resistive load), electrical life: 50,000 operations SPDT-NC, 250 VAC, 2A (resistive load), electrical life: 20,000 operations	
TRS	Re-transmitted Signal	4~20mA, 0~20mA, 0~5V, 0~10V, 1~5V, 2~10V	
	Source of Re-transmission	SV, PV	
	Accuracy	0.1%	
	Resolution	14 bit	
Remote SV	Signal	4~20mA, 0~20mA, 0~5V, 0~10V, 1~5V, 2~10V	
	Resolution	18 bit	
	controlled by	SV	
Communication	Interface	RS-485 Half duplex Communication MAX. 31 units, MAX. distance 1200 meters	
	Protocol	Modbus RTU, TAIE	
	Parity bit	NONE, ODD, EVEN	
	Data bit	8 bit	
	Stop bit	1 or 2 bit	
	Baud rate	2400,4800,9600,19200,38400,57600,115200 bps	
Malfunction vibration		10~55 Hz 20m / s ² , for 10 min each in X, Y and Z directions.	
Vibration resistance		10~55 Hz 20m / s ² , for 2 hr each in X, Y and Z directions.	
Malfunction shock		100m / s ² , 3 times each in X, Y and Z directions.	
Shock resistance		300m / s ² , 3 times each in X, Y and Z directions.	
Operating Environment Temperature/Humidity		0 ~ 50°C (in the case of no freezing or condensation) / 20% ~ 90% RH	
Storage Environment Temperature		-25 ~ 65°C (in the case of no freezing or condensation)	
Dimension (mm)		W40 x H107 x D43	
Weight		Approx.115g	

3. Input Range Table

Types of input			Code	Range	
				°C	°F
Thermocouple	K	K1	01	-50.0~600.0	-58.0~999.9
		K2	02	-50~1200	-58~2192
	J	J1	03	-50.0~400.0	-58.0~752.0
		J2	04	-50~1200	-58~2192
	R	R	05	-50~1760	-58~3200
	S	S	06	-50~1760	-58~3200
	B	B	07	-50~1820	-58~3308
	E	E	08	-50~900	-58~1652
	N	N	09	-50~1300	-58~2372
	T	T1	10	-199.9~400.0	-199.9~752.0
		T2	11	-199~400	-326~752
	W	W	12	-50~2320	-58~4208
	PL	PL	13	-50~1200	-58~2192
	L	L	14	-50~800	-58~1472
RTD	PT100	PT1	15	-199.9~850.0	-199.9~999.9
		PT2	16	-199~850	-326~1562
		PT3	17	0~850	32~1562
Linear	AN1	0~25mV	18	-1.999~9.999 -19.99~99.99 -199.9~999.9 -1999~9999	
	AN2	0~50mV	19		
		0~20mA	20		
		0~1V	21		
		0~2V	22		
		0~5V	23		
		0~10V	24		
	AN3	0~70mV	25		
	AN4	4~20mA	26		
		10~50mV	27		
		1~5V	28		
2~10V		29			

4. Packing List & Label Information

4.1 Packing List Guide

FY400/600/700/800/900

<ol style="list-style-type: none"> 1. Temperature Controller...1 unit 2. Mounting frame.....2 units 3. Brief manual.....1 pcs
--

FA230/231

<ol style="list-style-type: none"> 1. Temperature Controller...1 unit 2. Terminal cover.....2 units 3. Brief manual.....1 pcs
--

4.2 Label Guide

4.2.1 FY400

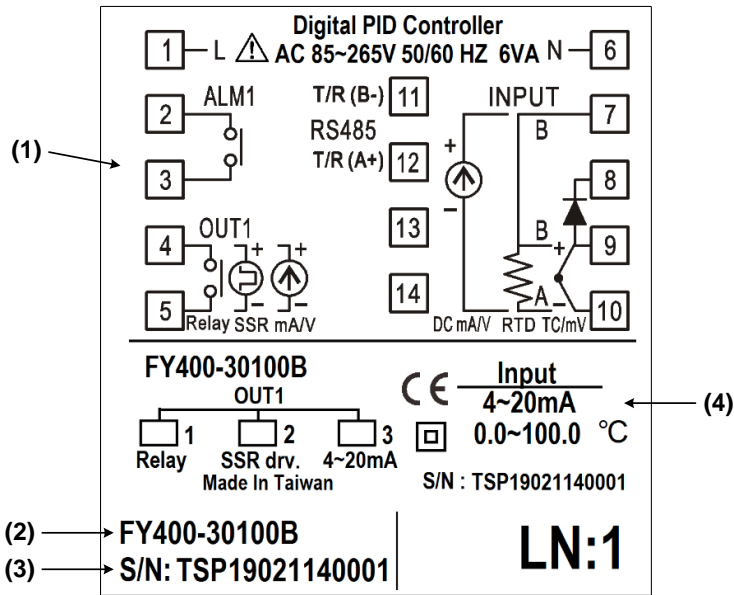

No.	Item	Description
(1)	Terminal arrangement	FY400 Terminal Wiring Diagram
(2)	Model number	FY400 model name
(3)	Serial number	TSP19021140001
(4)	Input type	Controller Input Signal and Range

4.2.2 FY700

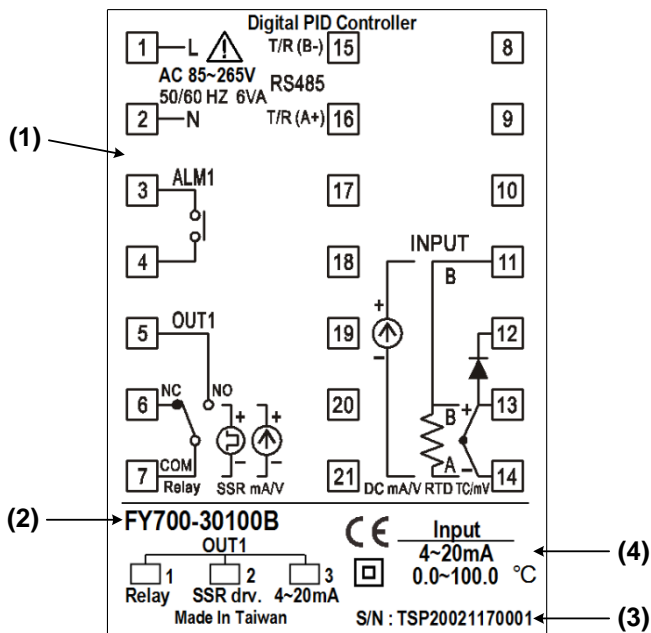

No.	Item	Description
(1)	Terminal arrangement	FY700 Terminal Wiring Diagram
(2)	Model number	FY700 model name
(3)	Serial number	TSP20021170001
(4)	Input type	Controller Input Signal and Range

4.2.3 FY600/800/900

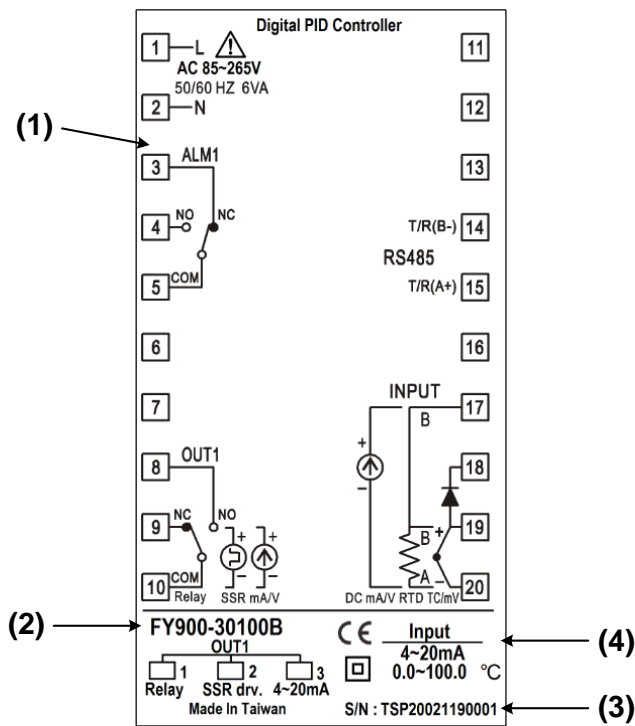

No.	Item	Description
(1)	Terminal arrangement	FY900 Terminal Wiring Diagram
(2)	Model number	FY900 model name
(3)	Serial number	TSP20021190001
(4)	Input type	Controller Input Signal and Range

4.2.4 FA230

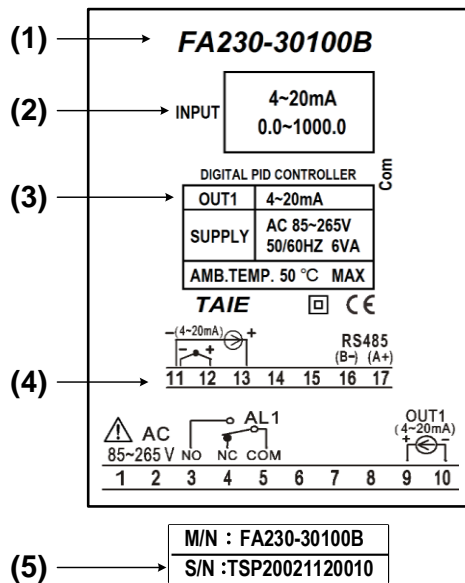

No.	Item	Description
(1)	Model number	FA230 model name
(2)	Input type	Controller Input Signal and Range
(3)	Control output	4~20mA
(4)	Terminal arrangement	FA230 Terminal Wiring Diagram
(5)	Serial number	TSP20021120010

4.2.5 FA231

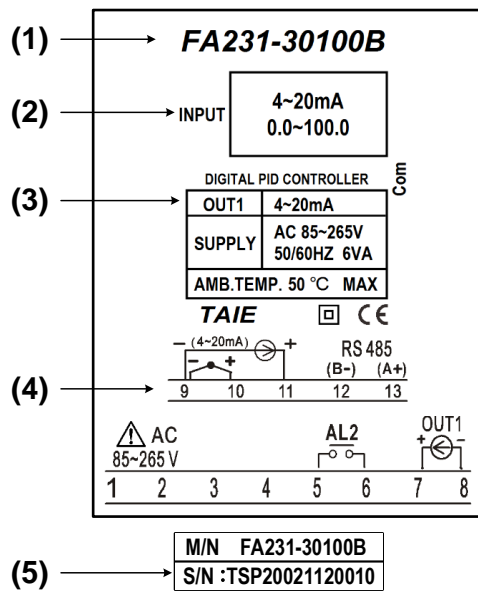

No.	Item	Description
(1)	Model number	FA231 model name
(2)	Input type	Controller Input Signal and Range
(3)	Control output	4~20mA
(4)	Terminal arrangement	FA231 Terminal Wiring Diagram
(5)	Serial number	TSP20021120010

5. Parts Description



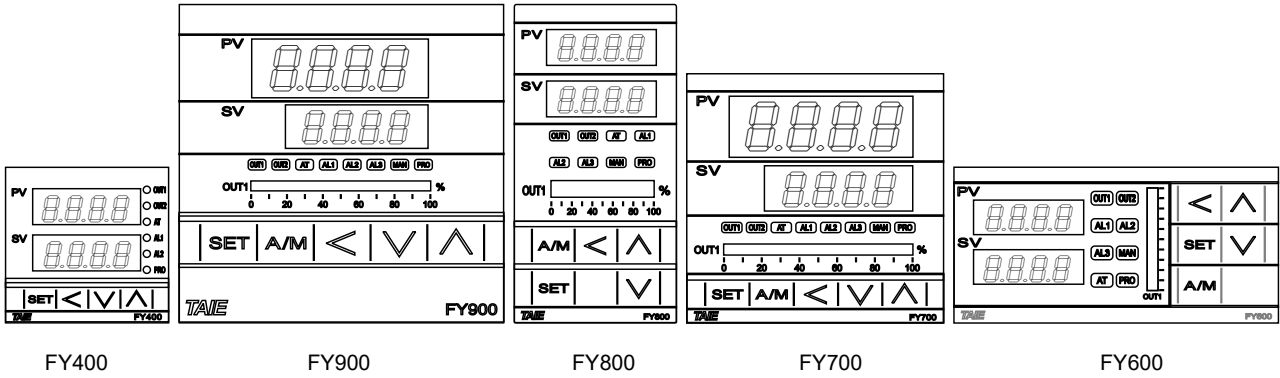

5.1 FY Series

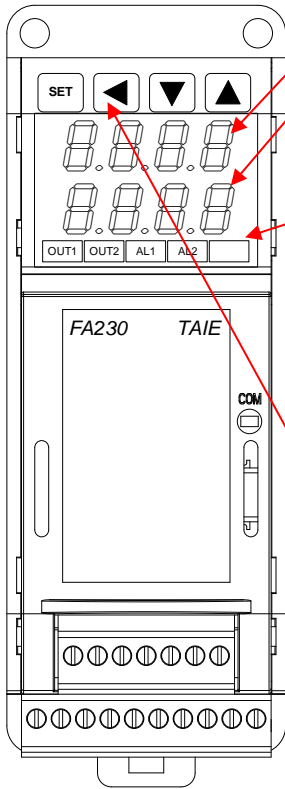

	1	PV	Indicating PV (measured value) and character information such as parameter codes or error codes(Red)	
	2	SV	Indicating SV (target set value) or parameter values(Green)	
	3	LED	OUT1	Lamp lit when OUT1 is activated (Green)
			OUT2	Lamp lit when OUT2 is activated (Green)
			AT	Lamp lit when Auto-tuning is activated (Orange)
			AL1	Lamp lit when Alarm 1 is activated (Red)
			AL2	Lamp lit when Alarm 2 is activated (Red)
			AL3	Lamp lit when Alarm 3 is activated (Red)
			MAN	Lamp lit when controller in manual mode or get error condition (Orange)
			PRO	When the program is executed, this light is on (orange)
	OUT1%	Output% bar-graph indicator(Green)		
4	Keypad		SET	For parameter call-up and set value registration
			A/M	Auto manual transfer
			SHIFT	Shift digits when changing settings
			DOWN	Decrease numerals
			UP	Increase numerals

5.2 FA Series



1		PV	Indicating PV (measured value) and character information such as parameter codes or error codes(Red)
2		SV	Indicating SV (target set value) or parameter values(Green)
3	LED	OUT1	Lamp lit when OUT1 is activated (Green)
		OUT2	Lamp lit when OUT2 is activated (Green)
		AL1	Lamp lit when Alarm 1 is activated (Red)
		AL2	Lamp lit when Alarm 2 is activated (Red)
			1. Lamp lit when Auto-tuning is activated (Orange) 2. When the program is executed, this light is on (orange)
		COM	Lights when controller response data (Orange)
4	Keypad	 SET	For parameter call-up and set value registration
		 SHIFT	Shift digits when changing settings
		 DOWN	Decrease numerals
		 UP	Increase numerals

6. Installation

6.1 FY400 Dimensions

(Unit: mm)

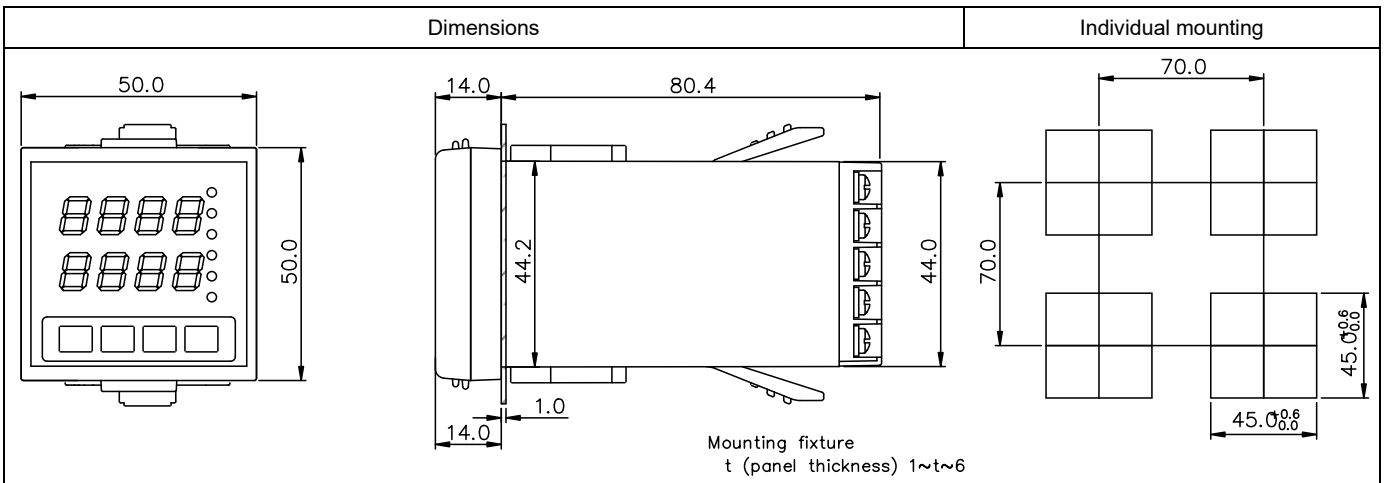

6.2 FY600 Dimensions

(Unit: mm)

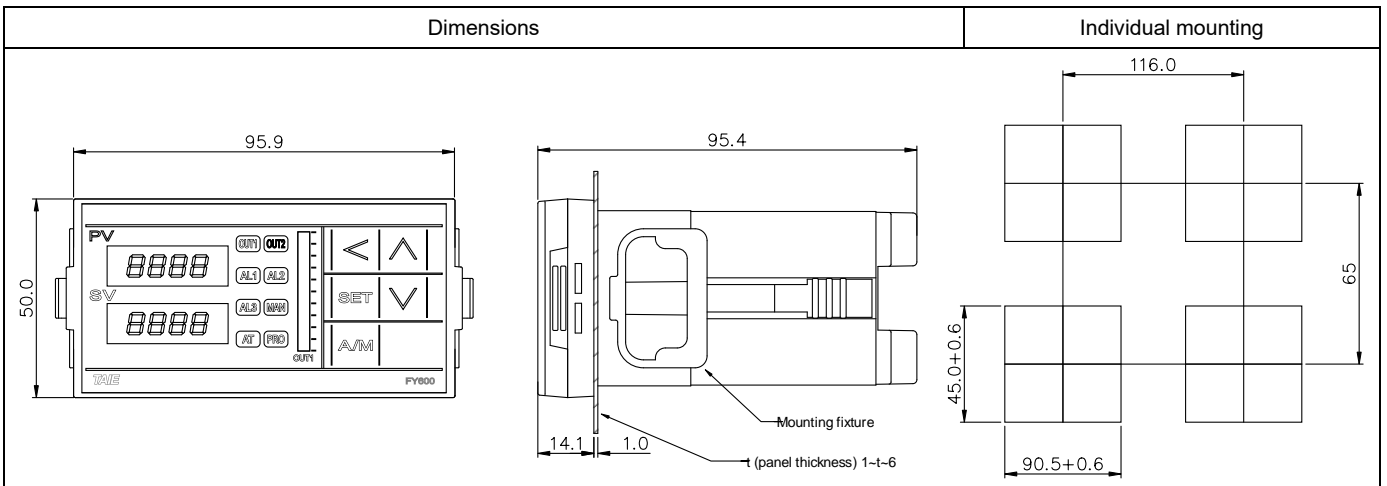

6.3 FY700 Dimensions

(Unit: mm)

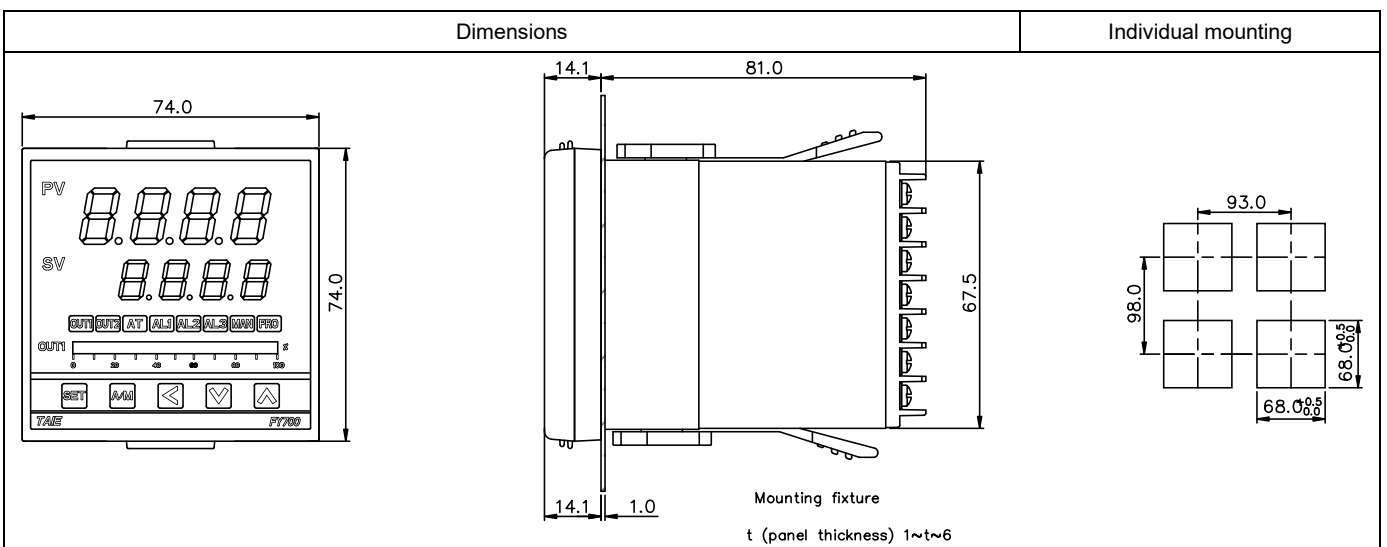

6.4 FY800 Dimensions

(Unit: mm)

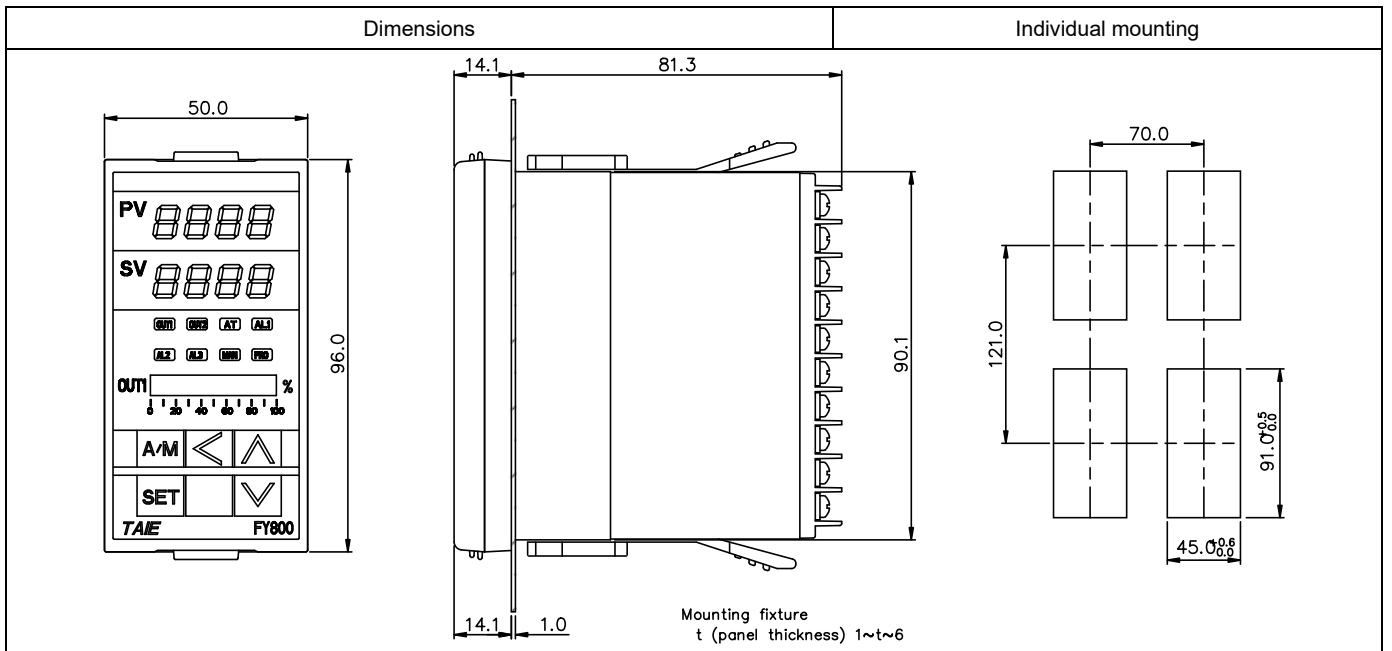

6.5 FY900 Dimensions

(Unit: mm)

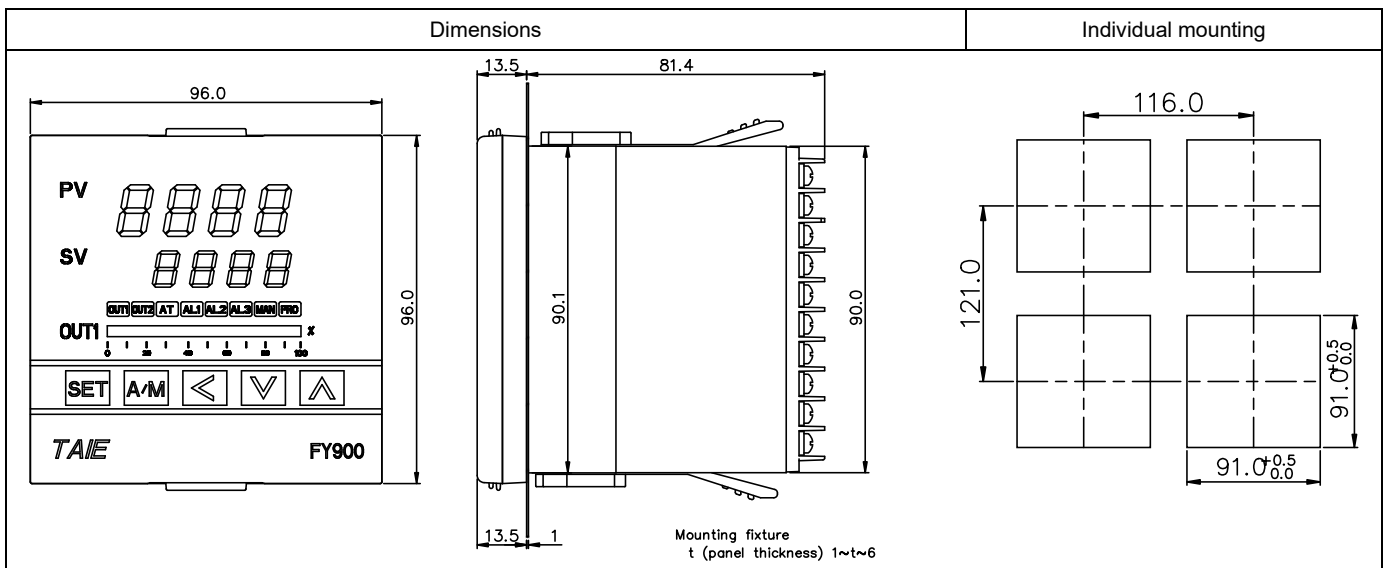

6.6 FA230/231 Dimensions

(Unit: mm)

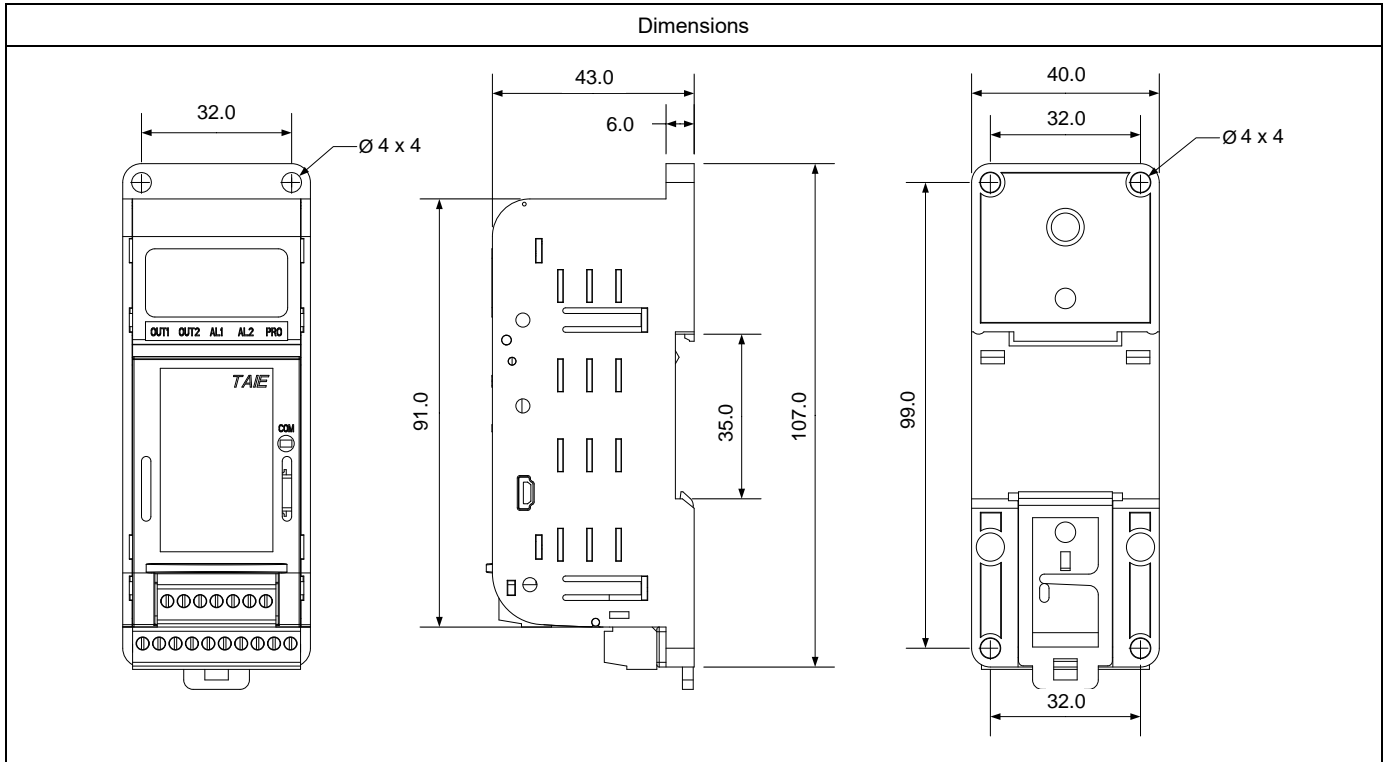

7. Terminal Arrangement

Caution

When implementing wiring for the controller power supply, please make sure that the power supply is turned off to avoid electric shock!
Do not touch the live parts, such as the terminals, while the power is on. Otherwise death or serious injury may be resulted from short circuit of the contact electrode.

7.1 FY400 Terminal Arrangement

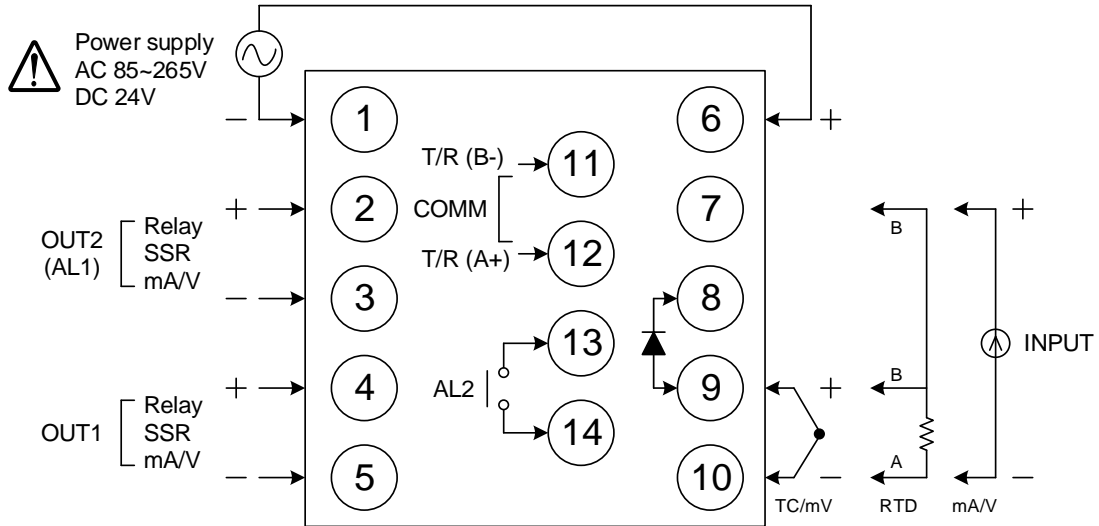

Power		Alarm-1 Alarm-2	
Output-1		Communication	
Output-2		Transmission	
1φ Zero cross	11 G1 12 K1 13 G2 14 K2	Remote SV	
		CT	
Motor valve	2 3 CLOSE 4 OPEN 5 COM	Input	

7.2 FY600 Terminal Arrangement

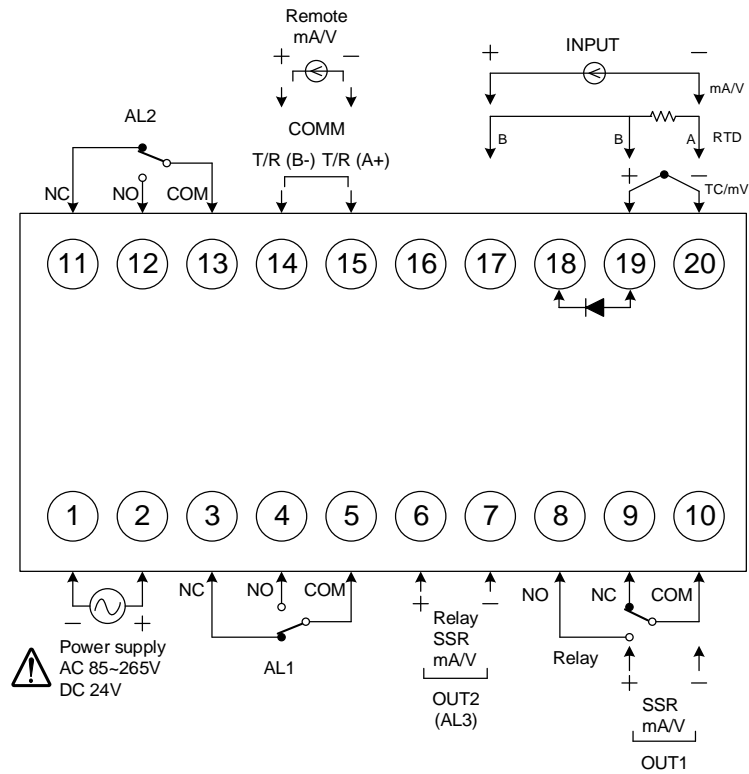

Power		Communication	
Output-1		Transmission	
Output-2		Remote SV/CT Input	
Motor valve		Alarm 1 Alarm 2 Alarm 3	
		Input	

7.3 FY700 Terminal Arrangement

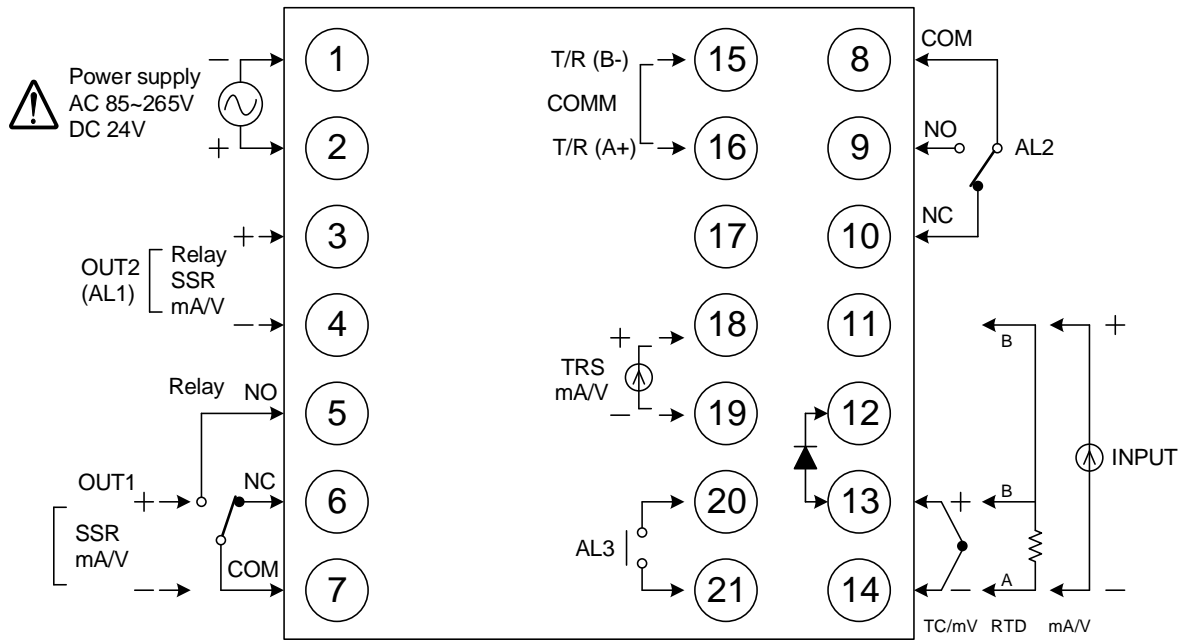

Power															
Output-1															
Output-2															
1φ Zero cross/ Phase angle	<table border="0"> <tr> <td>1φ Phase angle</td> <td>1φ Zero cross</td> </tr> <tr> <td>15 G1</td> <td>15 G1</td> </tr> <tr> <td>16 K1</td> <td>16 K1</td> </tr> <tr> <td>17 G2</td> <td>17 G2</td> </tr> <tr> <td>18 K2</td> <td>18 K2</td> </tr> <tr> <td>20 R</td> <td></td> </tr> <tr> <td>21 s</td> <td></td> </tr> </table> <p>* AC 220 / 380V * Power supply</p>	1φ Phase angle	1φ Zero cross	15 G1	15 G1	16 K1	16 K1	17 G2	17 G2	18 K2	18 K2	20 R		21 s	
1φ Phase angle	1φ Zero cross														
15 G1	15 G1														
16 K1	16 K1														
17 G2	17 G2														
18 K2	18 K2														
20 R															
21 s															
Motor valve															

Alarm 1 Alarm 2 Alarm 3	
Communication	
Transmission	
Remote SV	
CT Input	
Input	

7.4 FY800 Terminal Arrangement

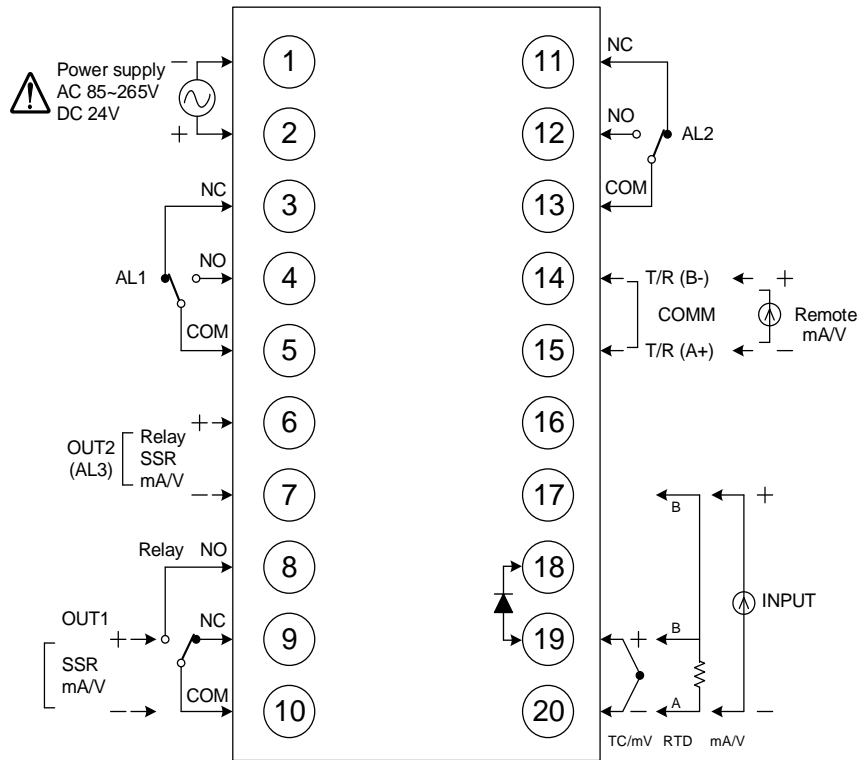

Power		Communication	
Output-1		Transmission	
Output-2		Remote SV/CT Input	
Motor valve		Alarm 1 Alarm 2 Alarm 3	
		Input	

7.5 FY900 Terminal Arrangement

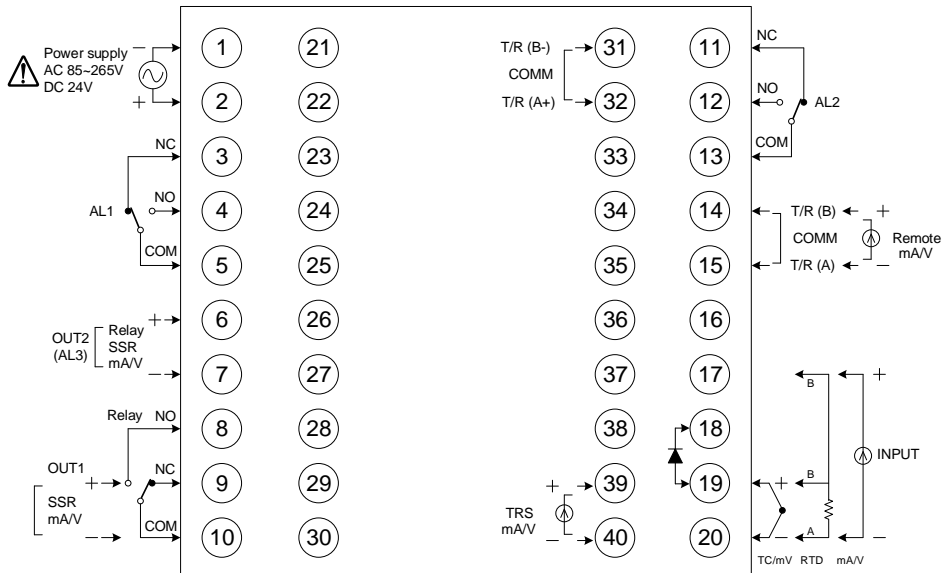

Power																			
Output-1																			
Output-2																			
3φ Zero cross	31 RG1 32 RK1 33 RG2 34 RK2 35 TG1 36 TK1 37 TG2 38 TK2																		
1φ Zero cross/ Phase angle	<table border="0"> <tr> <td>1φ Phase angle</td> <td>1φ Zero cross</td> </tr> <tr> <td>31 G1</td> <td>31 G1</td> </tr> <tr> <td>32 K1</td> <td>32 K1</td> </tr> <tr> <td>33 G2</td> <td>33 G2</td> </tr> <tr> <td>34 K2</td> <td>34 K2</td> </tr> <tr> <td>39 R</td> <td></td> </tr> <tr> <td colspan="2">* AC 220 / 380V</td> </tr> <tr> <td>40 S</td> <td></td> </tr> <tr> <td colspan="2">* Power supply</td> </tr> </table>	1φ Phase angle	1φ Zero cross	31 G1	31 G1	32 K1	32 K1	33 G2	33 G2	34 K2	34 K2	39 R		* AC 220 / 380V		40 S		* Power supply	
1φ Phase angle	1φ Zero cross																		
31 G1	31 G1																		
32 K1	32 K1																		
33 G2	33 G2																		
34 K2	34 K2																		
39 R																			
* AC 220 / 380V																			
40 S																			
* Power supply																			
Motor valve	6 7 CLOSE 8 OPEN 9 10 COM																		
Alarm 1 Alarm 2 Alarm 3																			
Communication	14 T/R (B-) or 31 T/R (B-) RS-485 15 T/R (A+) 32 T/R (A+)																		
Transmission																			
Remote SV/ CT Input																			
Input																			

7.6 FA230 Terminal Arrangement

Upper

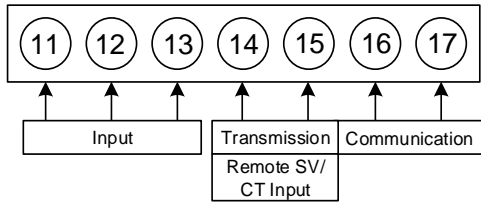

Down

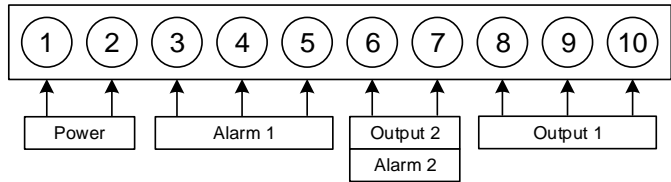

INPUT	
Transmission	
Remote SV / CT Input	
Communication	

Power	
Alarm	
Output 2	
Output 1	
Motor valve	

FA230 terminal diagram

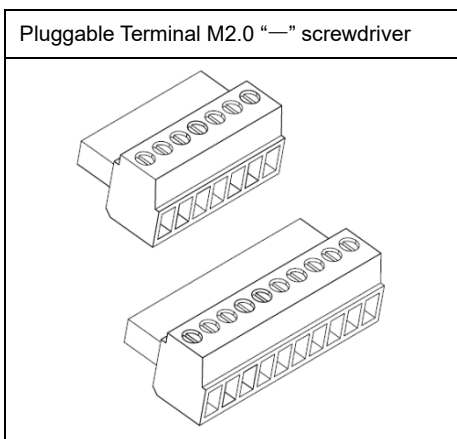

7.7 FA231 Terminal Arrangement

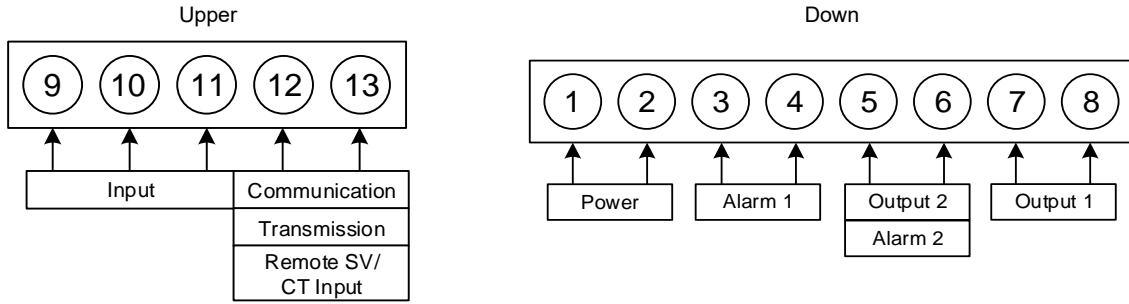

Input	<p>TC / mV: Terminal 9 (-), Terminal 10 (+) RTD: Terminal 9 (A), Terminal 10 (B), Terminal 11 (B)</p>
	<p>mA / V: Terminal 9 (-), Terminal 10 (+), Terminal 11 (+)</p>
Transmission	<p>mA / V: Terminal 12 (-), Terminal 13 (+)</p>
Remote SV / CT Input	<p>mA / V: Terminal 12 (-), Terminal 13 (+) CT: Terminal 12 (CT), Terminal 13 (CT)</p>
Communication	<p>RS-485: Terminal 12 (T/R (B-)), Terminal 13 (T/R (A+))</p>





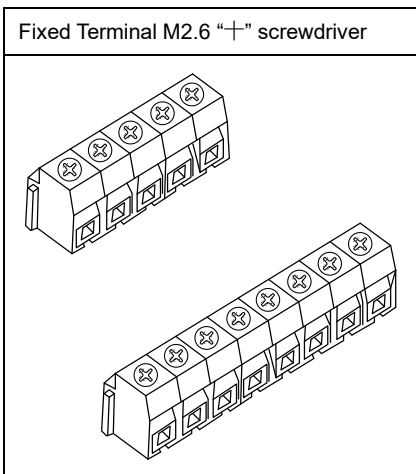









Power	<p>AC 85-265V: Terminal 1 (L), Terminal 2 (N) DC 24V: Terminal 1 (-), Terminal 2 (+) ⚠️</p>
Alarm	<p>AL1: Terminal 3 (-), Terminal 4 (+) AL2: Terminal 5 (-), Terminal 6 (+)</p>
Output 2	<p>Relay: Terminal 5 (-), Terminal 6 (+) SSR: Terminal 5 (+), Terminal 6 (-) mA / V: Terminal 5 (+), Terminal 6 (-)</p>
Output 1	<p>Relay: Terminal 7 (-), Terminal 8 (+) SSR: Terminal 7 (+), Terminal 8 (-) mA / V: Terminal 7 (+), Terminal 8 (-)</p>
Motor valve	<p>CLOSE: Terminal 5 (-), Terminal 6 (+) OPEN: Terminal 7 (-), Terminal 8 (+) COM: Terminal 7 (-), Terminal 8 (+)</p>

FA231 terminal diagram













8. Basic Function Setting



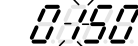









8.1 Changing Input Type

1.	PV  SV 	Display after power-on.	2.	PV  SV 	Hold SET key +  key 3 seconds, to enter LEVEL_3 upper display showing "INP1" with lower display showing current input type.
3.	PV  SV 	Press  key the lower display flashes.	4.	PV  SV 	Press  key and  key to enter the intended input type.
5.	PV  SV 	Press SET key to store new value of INP1.	Modify input type needs to interchange of jumper location, and it needs to recalibration for linear input type change. Please refer to chapter 14. "Modification of Input Signal" .		













8.2 SV Setting

1.	PV  SV 	Display after power-on.	2.	PV  SV 	When  key is pressed, the lower display flashes.
3.	PV  SV 	Press  key and  key to adjust set value.	4.	PV  SV 	Press SET key to store new value of SV.











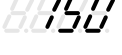



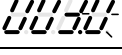

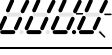

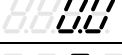
8.3 Setting PID Values Automatically(Auto-tuning)

1.	PV  SV 	Display after power-on.	2.	PV  SV 	Press SET key until show "AT" .
3.	PV  SV 	When  key is pressed, the lower display flashes.	4.	PV  SV 	Press  key or  key to select auto-tuning execution or not.
5.	PV  SV 	Press SET key to store new value of AT.	When auto-tuning AT LED lamp lit and start to output, through a few circles to get new PID value with the precise control, if finished the AT LED will be lamp off. Please refer to chapter 10.11 Auto-tuning and Startup tuning		

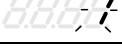

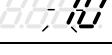











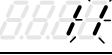

8.4 Setting PID Values Manually

1.	PV  SV 	Display after power-on.	2.	PV  SV 	Hold SET key 3 seconds, then entering LEVEL_2 upper display showing "P1", with lower display show current P1 value.
3.	PV  SV 	When  key is pressed, the lower display flashes.	4.	PV  SV 	Press  key and  key to set the intended P1 value.
5.	PV  SV 	Press SET key to store new value of P1.	By the same procedure, use the same ways to set integral time(I1) and derivative time(D1).		











8.5 Controlling With ON/OFF Action

1.	PV  SV 	Display after power-on.	2.	PV  SV 	Hold SET key 3 seconds, then entering LEVEL_2, as upper display shows "P1", with lower display showing current P1 value.
3.	PV  SV 	When  key is pressed, the lower display flashes, upper display.	4.	PV  SV 	Press  key until P1 = 0.0
5.	PV  SV 	Press SET key to store new value.	6.	PV  SV 	Press SET key until show "HYS1" °.
7.	PV  SV 	When  key is pressed, the lower display flashes.	8.	PV  SV 	Press  key and  key to set the intended HYS1 value.
9.	PV  SV 	Press SET key to store new value.	Heat mode formula: $PV \geq (SV + HYS1) \rightarrow OUT1 OFF$ $PV \leq (SV - HYS1) \rightarrow OUT1 ON$ Cool mode formula: $PV \geq (SV + HYS1) \rightarrow OUT1 ON$ $PV \leq (SV - HYS1) \rightarrow OUT1 OFF$		

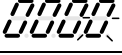

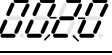



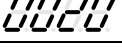



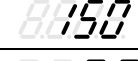

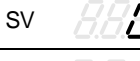
8.6 Alarm Mode Setting

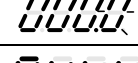
1.	PV  SV 	Display after power-on.	2.	PV  SV 	Hold SET key +  key 3 seconds, then entering LEVEL_3 upper display showing "INP1" with lower display showing current input type.
3.	PV  SV 	Press SET key until show "ALD1" °.	4.	PV  SV 	When  key is pressed, the lower display flashes
5.	PV  SV 	Press  key and  key to set the intended ALD1 value.	6.	PV  SV 	Press SET key to store new value of ALD1. ※ Please refer to ch11.1 Alarm mode.

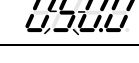
8.7 Alarm Value Setting

1.	PV  SV 	Display after power-on.	2.	PV  SV 	Press SET key until show "AL1" °.
3.	PV  SV 	When  key is pressed, the lower display flashes.	4.	PV  SV 	Press  key and  key to set the intended AL1 value.
5.	PV  SV 	Press SET key to store new value of AL1.			

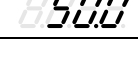
8.8 Controlling With Manual Control

1.	PV  SV 	Display after power-on.	2.	PV  SV 	Hold  2 seconds.
3.	PV  SV 	When  key is pressed, the lower display flashes.	4.	PV  SV 	Press  key and  key to set the intended output% value.
5.	PV  SV 	Press  key to store new value.	In manual mode OUTL=100.0 , output=100.0 % continuously. In manual mode OUTL=20.0 , output=20.0 % continuously.		

9. Flow Chart of Parameter Setting

9.1 Level Operation Mode





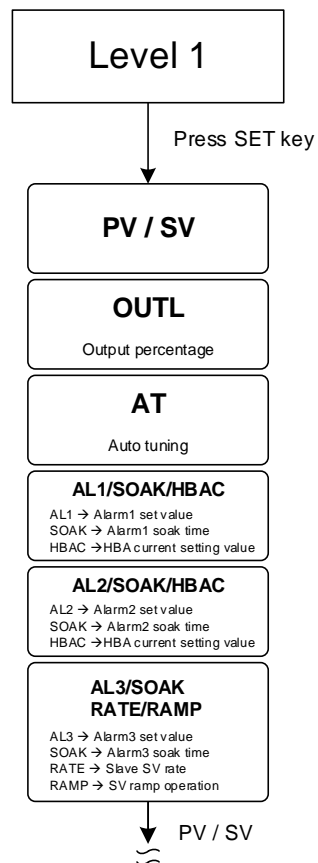







1. LEVEL 1 enter to the LEVEL 2
Hold SET key for 3 seconds then entering LEVEL 2
2. LEVEL 1 enter to the LEVEL 3
Hold SET key + SHIFT key for 3 seconds then entering LEVEL 3
3. LEVEL 2 return to the LEVEL 1
Hold SET key for 3 seconds then return to LEVEL 1
4. LEVEL 2 enter to the LEVEL 3
Hold SET key for 3 seconds then entering to LEVEL 3
5. LEVEL 2 enter to the LEVEL 4
On the LEVEL 2 then press SET key to find parameter "LCK modify LCK value from current value to 1111 after hold SET key + SHIFT key 3 seconds entering LEVEL 4
6. LEVEL 3 return to the LEVEL 1
Hold SET key + SHIFT key for 3 seconds then return to LEVEL 1
7. LEVEL 3 return to the LEVEL 2
Hold SET key for 3 seconds then return to LEVEL 2
8. LEVEL 4 return to the LEVEL 1
Hold SET key + SHIFT key for 3 seconds then return to LEVEL 1
9. LEVEL 4 return to the LEVEL 2
Hold SET key for 3 seconds then return to LEVEL 2

9.4 Level 1 (User Level) All Parameters Display



※ : If no key is pressed within 60 seconds, it will automatically return to LEVEL 1 (user level) and display PV/SV

9.5 LEVEL_1 Parameter

Parameter	Symbol	Content	Range		Default	Hide/Display
			MAX	MIN		
PV	---	Process value	USPL	LSPL	---	---
SV	---	Set value	USPL	LSPL	---	---
OUTL		High limit setting of manipulated value when PID gain > OUTL use OUTL as manipulated value	100.0	0.0	100.0	SET1.1
AT		Auto-tuning execute selection 0 : NO (PID control) 1 : YES (execute auto-tuning) 2 : PR.TU (Startup tuning, execute once) 3 : PRTU (Startup tuning, execute always when reboot)	PRTU	NO	NO	SET1.2
*AL1		Alarm1 set value (Please refer to Chapter 11)	USPL	-1999	1.0	SET1.3
SOAK		Alarm1 soak time Time format : hr.min	99.59	0.00	0.10	ALD1=10 or ALD1=19
HBAC		HBA current setting value Upper : heater current display Down : current setting value unit : ampere(A)	100.0	0.0	1.0	INP2=4 & ALD1=9
*AL2		Alarm2 set value (Please refer to Chapter 11)	USPL	-1999	1.0	SET1.4
HBAC		HBA current setting value Upper : heater current display Down : current setting value unit : ampere(A)	100.0	0.0	1.0	INP2=4 & ALD2=9
SOAK		Alarm2 soak time Time format : hr.min	99.59	0.00	0.10	ALD2=10 or ALD2=19
*AL3		Alarm3 set value (Please refer to Chapter 11)	USPL	-1999	1.0	SET2.1
SOAK		Alarm3 soak time Time format : hr.min	99.59	0.00	0.10	ALD3=10
RAMP		The rate of change during SV ramp operation format : °C / minute (Please refer to Chapter 10.7)	99.99	-19.99	10.00	ALD3=9 & SET2.1
RATE		Slave SV rate RATE SV = SV x (RATE/9999) (Please refer to Chapter 10.9)	9999	0	9999	SET2.1 & SET0.2

* Automatically display corresponding parameters according to different setting conditions

EX1: When alarm1 is used as HBA function(ALD1= 09), original AL1 will become HBAC display

EX2: When alarm2 is used as SOAK_B function(ALD2= 19), original AL2 will become SOAK display

EX3: When alarm3 is used as RAMP function(ALD3= 09), original AL3 will become RAMP display

9.6 Level 2 (PID Level) All Parameters Display

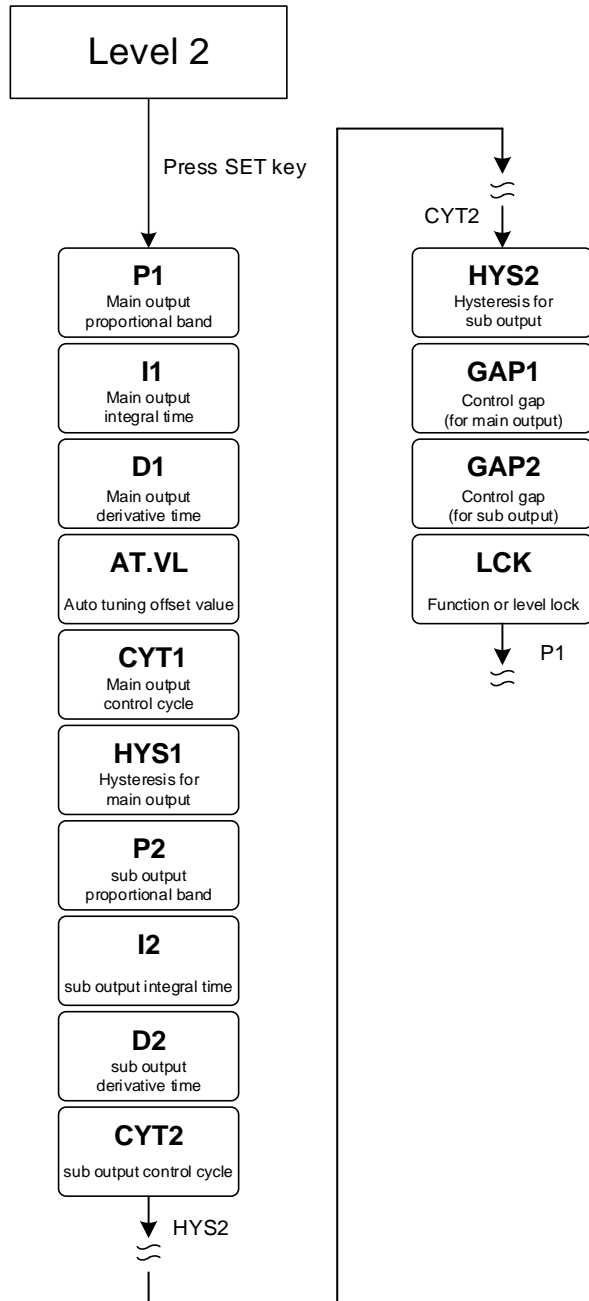

※ If no key is pressed within 60 seconds, it will automatically return to LEVEL 1 (user level) and display PV/SV

9.7 LEVEL_2 Parameter

Parameter	Symbol	Content	Range		Default	Hide/Display
			MAX	MIN		
P1		Main output proportional band 0.0 : ON/OFF control Other values : proportional band setting value	200.0	0.0	3.0	---
I1		Main output integral time 0 : disable integral function Other values : integral time setting value	3600	0	240	---
D1		Main output derivative time 0 : disable derivative function Other values : derivative time setting value	900	0	60	---
AT.VL		Auto-tuning offset value execute auto-tuning in (SV+ATVL) point	100.0	-100.0	0.0	---
CYT1		Main output control cycle 0 : Linear signal 1 : SSR drive 2~150 : Relay	150	0	10	---
HYS1		Hysteresis for main output on/off control use(when P1 = 0.0 appear) heating formula : $PV \geq (SV + HYS1) \rightarrow OUT1=OFF$ $PV \leq (SV - HYS1) \rightarrow OUT1=ON$ cooling formula : $PV \geq (SV + HYS1) \rightarrow OUT1=ON$ $PV \leq (SV - HYS1) \rightarrow OUT1=OFF$	100.0	-100.0	1.0	P1 = 0.0
P2		Sub output proportional band 0.0 : ON/OFF control Other values : proportional band setting value	200.0	0.0	3.0	OUTY = 1
I2		Sub output integral time 0 : disable integral function Other values : integral time setting value	3600	0	240	OUTY = 1
D2		Sub output derivative time 0 : disable derivative function Other values : derivative time setting value	900	0	60	OUTY = 1
CYT2		Sub output control cycle 0 : Linear signal 1 : SSR drive 2~150 : Relay	150	0	10	OUTY = 1
HYS2		Hysteresis for sub output on/off control use(when P2 = 0.0 appear)	100.0	-100.0	1.0	P2 = 0.0
GAP1		Control gap (for main output)	1000	-1000	0	OUTY = 1
GAP2		Control gap (for sub output)	1000	-1000	0	OUTY = 1
LCK		Function or level lock (Please refer to Chapter 9.3 Data Lock Function)	1111	0000	0000	---

9.8 Level 3 (Input Level) All Parameters Display

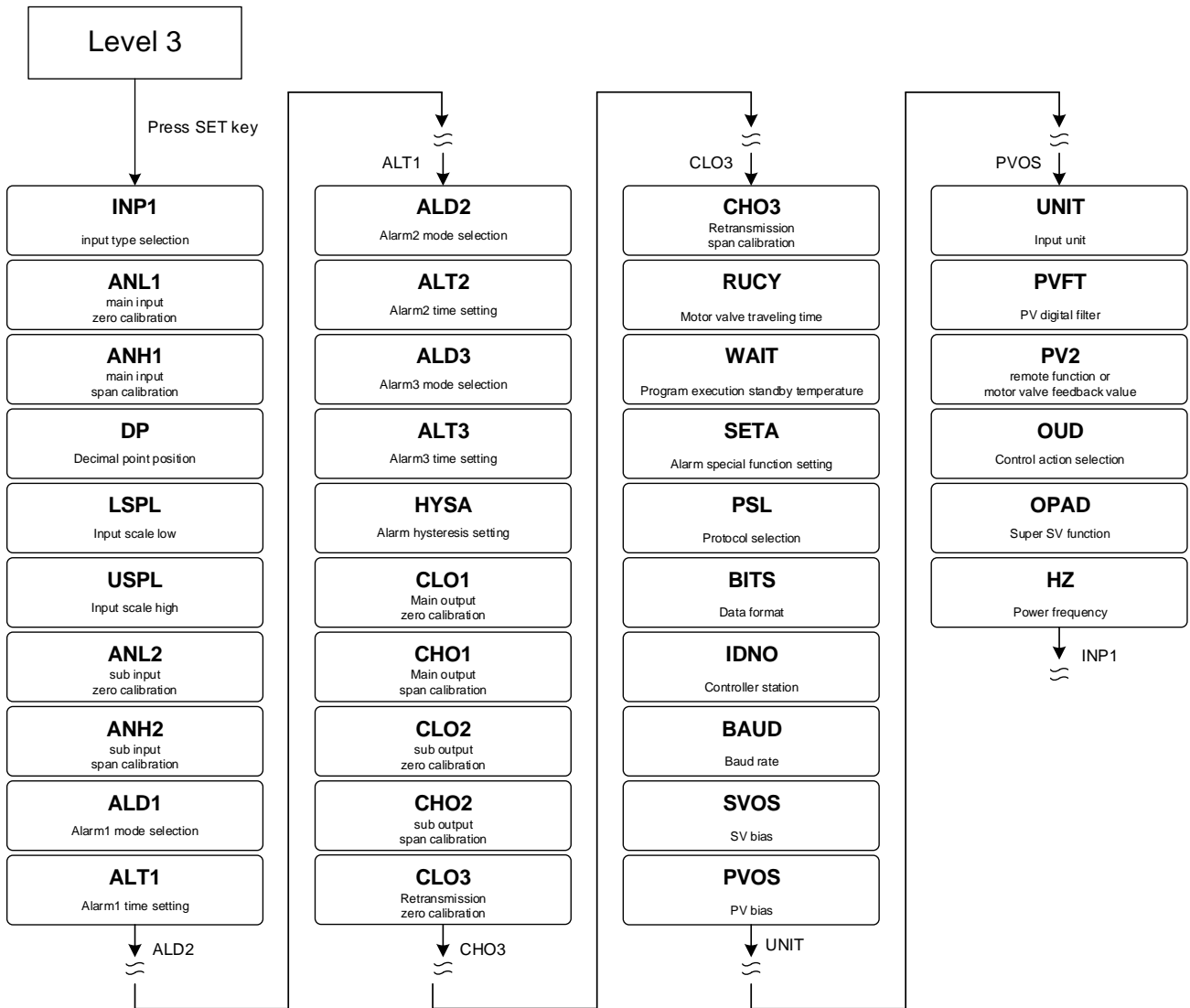









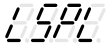

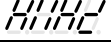
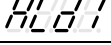
※ If no key is pressed within 60 seconds, it will automatically return to LEVEL 1 (user level) and display PV/SV

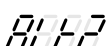
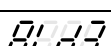
9.9 LEVEL_3 Parameter

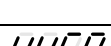
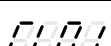
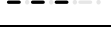
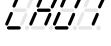
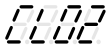
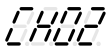
Parameter	Symbol	Content	Range		Default	Hide/Display
			MAX	MIN		
INP1		Main input type selection Change this parameter USPL&LSPL will be reset (please refer to Chapter 3 Input Range Table)	AN4	K1	K1	---
ANL1		Main input zero calibration, only available in linear input (Please refer to chapter 14.4)	9999	-1999	0	SET2.2
ANH1		Main input span calibration, only available in linear input (hex display) (Please refer to chapter 14.4)	0x7FFF	0x0000	0x5FFF	SET2.2
DP		Decimal point position (only available in linear signal input AN1~AN4) 0 : 0000 1 : 000.0 2 : 0.00 3 : 0.000	0.000	0000	000.0	SET2.2

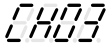
9.9 LEVEL_3 Parameter

Parameter	Symbol	Content	Range		Default	Hide/Display
			MAX	MIN		
LSPL		Input scale low	9999	-1999	---	SET2.3
USPL		Input scale high	9999	-1999	---	SET2.3
ANL2		Sub input zero calibration	9999	-1999	0	SET2.4
ANH2		Sub input span calibration (hex display)	0x7FFF	0x0000	0x5FFF	SET2.4
ALD1		Alarm1 mode selection (Please refer to Chapter 11.1 Alarm Mode)	19	0	11	SET3.1
ALT1		Alarm1 time setting 0.00 : Flicker 99.59 : Continued ON 0.01~99.58 : delay time Time format : min . sec	99.59	0.00	99.59	SET3.2
ALD2		Alarm2 mode selection (Please refer to Chapter 11.1 Alarm Mode)	19	0	0	SET3.3
ALT2		Alarm2 time setting 0.00 : Flicker 99.59 : Continued ON 0.01~99.58 : delay time Time format : min . sec	99.59	0.00	99.59	SET3.4
ALD3		Alarm3 mode selection (Please refer to Chapter 11.1 Alarm Mode)	18	0	0	SET4.1
ALT3		Alarm3 time setting 0.00 : Flicker 99.59 : Continued ON 0.01~99.58 : delay time Time format : min . sec	99.59	0.00	99.59	SET4.2
HYSA		Hysteresis setting for alarm1~3	999.9	-199.9	1.0	SET4.3
CLO1		Main output zero calibration , only available in linear output (Please refer to Chapter 13.5)	9999	0	0	SET4.4
CHO1		Main output span calibration , only available in linear output (Please refer to Chapter 13.5)	9999	0	3600	SET4.4
CLO2		Sub output zero calibration , only available in linear output	9999	0	0	SET5.1
CHO2		Sub output span calibration , only available in linear output	9999	0	3600	SET5.1
CLO3		Retransmission zero calibration	9999	0	0	SET5.2
CHO3		Retransmission span calibration	9999	0	3600	SET5.2
RUCY		Motor valve traveling time unit : second (Please refer to Chapter 10.6)	150	5	5	SET5.3
WAIT		Program execution standby temperature 0 : when program executed reach SV do not waiting for PV temperature Other values : when PV= (target SV-WAIT), program entering next segment (Please refer to Chapter 12)	100.0	0	0	SET5.3

9.9 LEVEL_3 Parameter

Parameter	Symbol	Content	Range		Default	Hide/Display
			MAX	MIN		
SETA		Alarm special function setting (Please refer to Chapter 11.2)	1111	0000	0000	SET5.3
PSL		Protocol selection 0 : TAIE 1 : RTU (Please refer to communication manual)	RTU	TAIE	RTU	SET5.4
BITS		Data format 0 : O_81 (parity bit=odd, stop bit=1) 1 : O_82 (parity bit=odd, stop bit=2) 2 : E_81 (parity bit=even, stop bit=1) 3 : E_82 (parity bit=even, stop bit=2) 4 : N_81 (parity bit=none, stop bit=1) 5 : N_82 (parity bit=none, stop bit=2)	N_82	O_81	O_81	SET5.4
IDNO		Controller station	254	0	1	SET5.4
BAUD		Baud rate 0 : 24(2400) 1 : 48(4800) 2 : 96(9600) 3 : 192(19200) 4 : 384(38400) 5 : 576(57600) 6 : 1152(115200) bps	1152	24	384	SET5.4
SVOS		SV bias	100.0	-100.0	0	SET6.1
PVOS		PV bias $PV = PV \times (PVOH / 5000) + PVOS$	199.9	-199.9	0	SET6.2
UNIT		Unit Change this parameter USPL&LSPL will be reset 0 : °C 1 : °F 2 : U (Linear signal)	2	0	---	SET6.3
PVFT		PV digital filter The PV filter is used to eliminate noise against the measured input Unit : second	10.00	0.01	2.00	SET6.4
PV2		Use for motor valve feedback value	100.0	0.0	---	OUTY=2 & SET7.1
OUT		Control action selection 0 : HEAT reverse action 1 : COOL direct action	COOL	HEAT	HEAT	SET7.2
OPAD		Super SV function, suppressing overshoot 0 : OFF 1 : ON	ON	OFF	OFF	SET7.3
HZ		Power frequency 0 : 50HZ 1 : 60HZ	50HZ	60HZ	60HZ	SET7.4

9.10 Level 4 (Setting Level) All Parameters Display

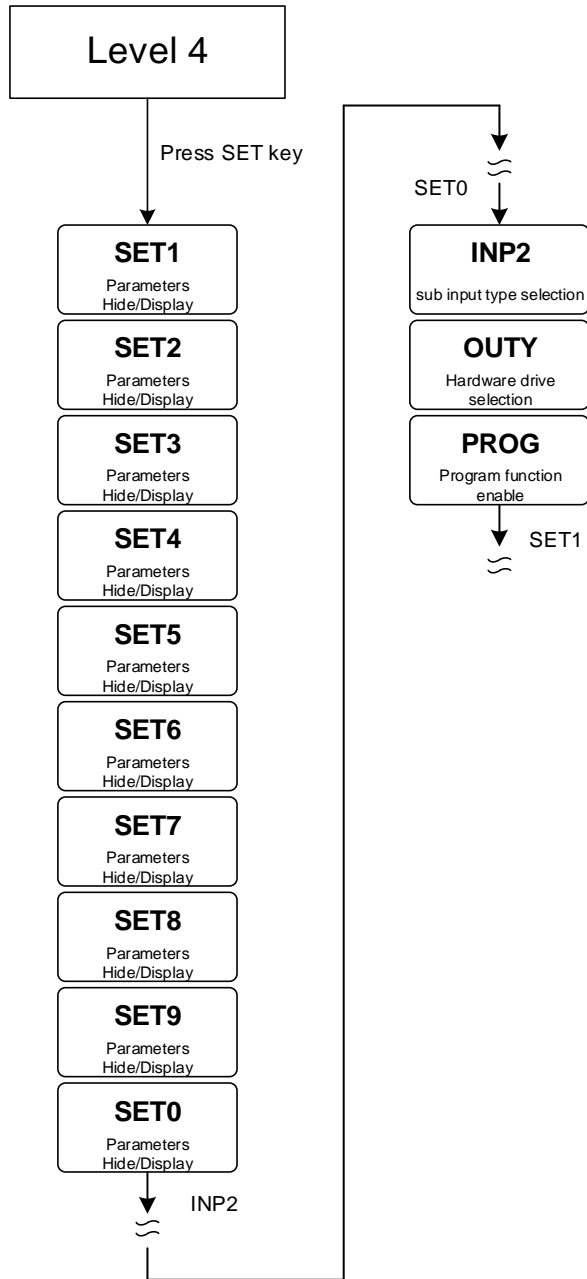

※ If no key is pressed within 60 seconds, it will automatically return to LEVEL 1 (user level) and display PV/SV

9.11 LEVEL_4 Parameter

Parameter	Symbol	Content	Range		Default	Hide/Display
			MAX	MIN		
SET1	SEEE1	Parameters Hide/Display	1111	0000	---	---
SET2	SEEE2	Parameters Hide/Display	1111	0000	---	---
SET3	SEEE3	Parameters Hide/Display	1111	0000	---	---
SET4	SEEE4	Parameters Hide/Display	1111	0000	---	---
SET5	SEEE5	Parameters Hide/Display	1111	0000	---	---
SET6	SEEE6	Parameters Hide/Display	1111	0000	---	---
SET7	SEEE7	Parameters Hide/Display	1111	0000	---	---
SET8	SEEE8	Parameters Hide/Display	1111	0000	---	---
SET9	SEEE9	Parameters Hide/Display	1111	0000	---	---

9.11 LEVEL_4 Parameter

Parameter	Symbol	Content	Range		Default	Hide/Display
			MAX	MIN		
SET0	<i>SE00</i>	Function enable/disable	1111	0000	---	---
INP2	<i>INP2</i>	Sub input type selection 0 : none 1 : 10~50mV / 4~20mA / 1~5V / 2~10V (only available in remote SV) 2 : 0~50mV / 0~20mA / 0~5V / 0~10V (only available in remote SV) 3 : valve feedback 4 : CT input	4	0	0	---
OUTY	<i>OUTY</i>	Hardware drive selection 0 : single output control 1 : dual output control 2 : valve control with feedback 3 : valve control without feedback selection 4 : single phase angle control	4	0	0	---
PROG	<i>PR00</i>	Program function enable 0 : OFF , SV source from keypad or communication 1 : ON , SV source from program	ON	OFF	OFF	---

9.12 Parameters Hide/Display Table on Level 4

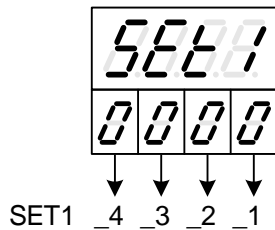

<i>SE00</i>	SET1_1	0	Hide	OUTL
		1	Display	OUTL
	SET1_2	0	Hide	AT
		1	Display	AT
	SET1_3	0	Hide	AL1
		1	Display	AL1
	SET1_4	0	Hide	AL2
		1	Display	AL2
<i>SE02</i>	SET2_1	0	Hide	AL3
		1	Display	AL3
	SET2_2	0	Hide	ANL1 ANH1 DP TRCL TRCH
		1	Display	ANL1 ANH1 DP TRCL TRCH
	SET2_3	0	Hide	LSPL USPL
		1	Display	LSPL USPL
	SET2_4	0	Hide	ANL2 ANH2
		1	Display	ANL2 ANH2
<i>SE03</i>	SET3_1	0	Hide	ALD1
		1	Display	ALD1
	SET3_2	0	Hide	ALT1
		1	Display	ALT1
	SET3_3	0	Hide	ALD2
		1	Display	ALD2
	SET3_4	0	Hide	ALT2
		1	Display	ALT2
<i>SE04</i>	SET4_1	0	Hide	ALD3
		1	Display	ALD3
	SET4_2	0	Hide	ALT3
		1	Display	ALT3
	SET4_3	0	Hide	HYSA
		1	Display	HYSA
	SET4_4	0	Hide	CLO1 CHO1
		1	Display	CLO1 CHO1

<i>5555</i>	SET5_1	0	Hide	CLO2 CHO2
		1	Display	CLO2 CHO2
	SET5_2	0	Hide	CLO3 CHO3
		1	Display	CLO3 CHO3
	SET5_3	0	Hide	RUCY WAIT SETA
		1	Display	RUCY WAIT SETA
	SET5_4	0	Hide	PSL BITS IDNO BAUD W MD
		1	Display	PSL BITS IDNO BAUD W MD

<i>5556</i>	SET6_1	0	Hide	SVOS
		1	Display	SVOS
	SET6_2	0	Hide	PVOS PVOH
		1	Display	PVOS PVOH
	SET6_3	0	Hide	UNIT
			Disable Fast Level	
		1	Display	UNIT
	SET6_4	0	Hide	PVFT
		1	Display	PVFT

<i>5557</i>	SET7_1	0	Hide	PV2
		1	Display	PV2
	SET7_2	0	Hide	ODU
		1	Display	ODU
	SET7_3	0	Hide	OPAD
		1	Display	OPAD
	SET7_4	0	Hide	HZ
		1	Display	HZ

<i>5558</i>	SET8_1	0	Program not repeat	
		1	Program repeat	
	SET8_2	0	No power failure protection	
		1	With power failure protection	
	SET8_3	0	Hide	PVST
			Program execute from 0	
		1	Display	PVST
	SET8_4	0	Hide	MLNB COMP OFFS
		1	Display	MLNB COMP OFFS

<i>5559</i>	SET9_1	0	Disable piece linear compensation	
		1	Enable piece linear compensation	
	SET9_2	0	Program Timer Unit = "Hour : Minute"	
		1	Program Timer Unit = "Minute : Second"	
	SET9_3	0	Disable transmission SV	
		1	Enable transmission SV	
	SET9_4	0	Disable transmission PV	
		1	Enable transmission PV	

<i>5560</i>	SET0_1	0	TTL Communication (Slave)	
		1	TTL Communication (Master)	
	SET0_2	0	Hide	RATE
		1	Display	RATE
	SET0_3	0	Disable Remote SV function	
		1	Enable Remote SV function	
	SET0_4	0	use output relay "b" contact when motor valve closed	
		1	use output relay "a" contact when motor valve closed	

9.13 Fast Level All Parameters Display

FY/FA controller provides a fast parameter access operation, easy for users to quickly access communication group, program group, motor valve group related parameters

SET6.3 = 1 (Enable Fast Level)

Enter fast level : press down key for 3 seconds at any level

Leave fast level : press down key for 3 seconds at fast level

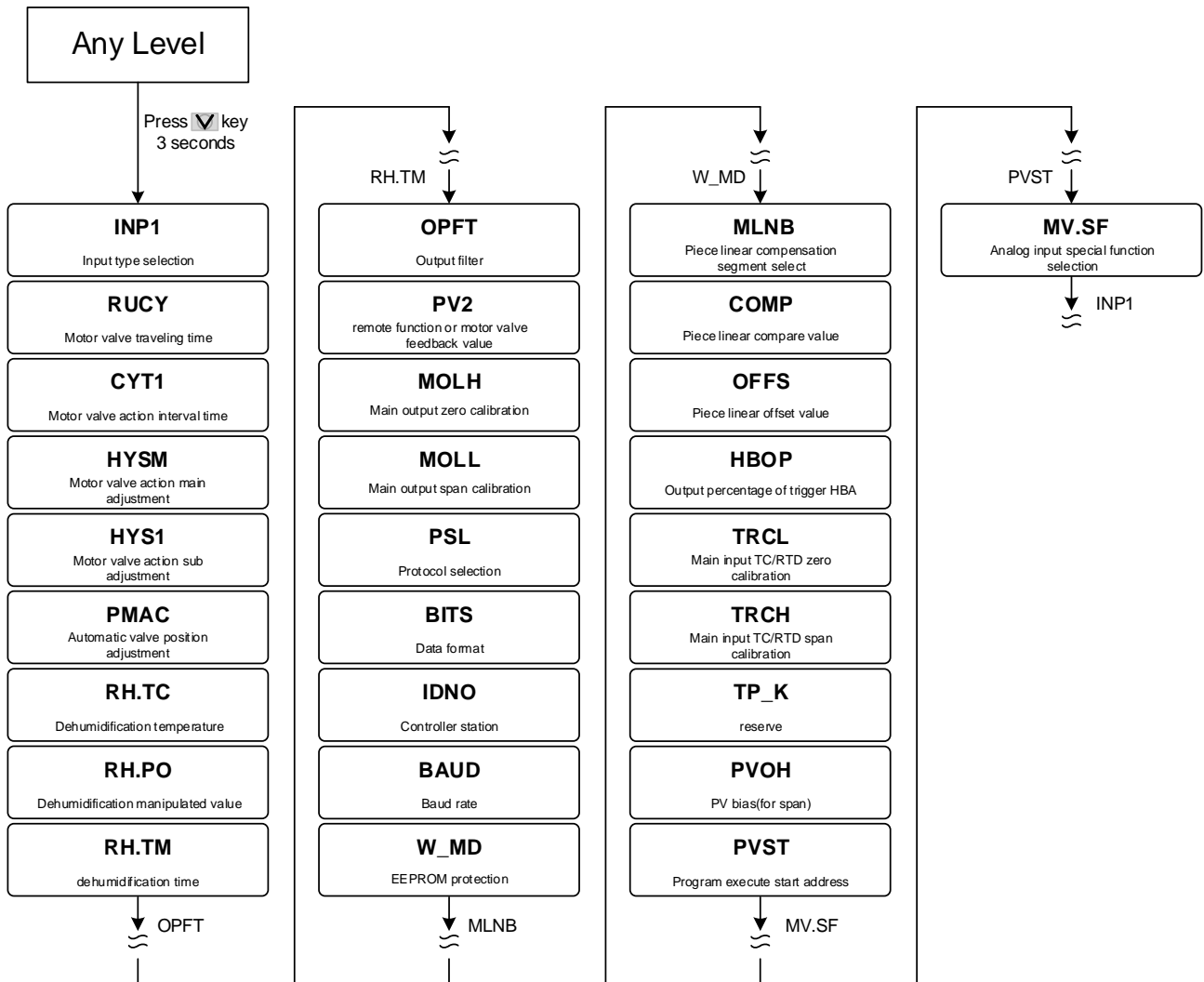

9.14 Fast Level Parameter

Parameter	Symbol	Content	Range		Default	Hide/Display
			MAX	MIN		
INP1		Main input type selection Change this parameter USPL&LSPL will be reset (Please refer to Chapter 3 Input Range Table)	AN4	K1	K1	---
RUCY		Motor valve traveling time Time unit : second (Please refer to Chapter 10.6)	150	5	5	OUTY = 2 or 3
CYT1		Motor valve action interval time. Time unit : second	10	0	5	OUTY = 2 or 3
HYSM		Motor valve action main adjustment unit : percentage	5.0	0.0	1.0	OUTY = 2 or 3
HYS1		Motor valve action sub adjustment unit : percentage	HYSM	0.0	0.5	OUTY = 2 or 3
PMAC		Automatic valve position adjustment 0 : OFF stop automatic adjust 1 : ON start automatic adjust 2 : E_PB Valve position determined by external button	E_PB	OFF	OFF	OUTY=2
RH.TC		Dehumidification temperature If PV less than RHTC manipulated value = RHPO (Please refer to Chapter 10.5)	200.0	0.0	125.0	---

9.14 Fast Level Parameter

Parameter	Symbol	Content	Range		Default	Hide/Display
			MAX	MIN		
RH.PO		Dehumidification manipulated value 0 : OFF disable dehumidification function Other values : 0.1~100.0 manipulated value (Please refer to Chapter 10.5)	100.0	OFF	OFF	---
RH.TM		Dehumidification time time format : min.sec	99.59	0.00	15.00	---
OPFT		Output filter unit: second	10.00	0.10	2.00	---
PV2		Use for motor valve feedback value	100.0	0.0	---	OUTY=2 & SET7.1
MOLH		High limit setting of manipulated value for main output	100.0	0.0	100.0	---
MOLL		low limit setting of manipulated value for main output	100.0	0.0	0.0	---
PSL		Protocol selection 0 : TAIE 1 : RTU (Please refer to communication manual)	RTU	TAIE	RTU	SET5.4
BITS		Data format 0 : O_81 (parity bit=odd, stop bit=1) 1 : O_82 (parity bit=odd, stop bit=2) 2 : E_81 (parity bit=even, stop bit=1) 3 : E_82 (parity bit=even, stop bit=2) 4 : N_81 (parity bit=none, stop bit=1) 5 : N_82 (parity bit=none, stop bit=2)	N_82	O_81	O_81	SET5.4
IDNO		Controller station	254	0	1	SET5.4
BAUD		Baud rate 0 : 24(2400) 1 : 48(4800) 2 : 96(9600) 3 : 192(19200) 4 : 384(38400) 5 : 576(57600) 6 : 1152(115200) bps	1152	24	384	SET5.4
W_MD		EEPROM protection 0 : OFF communication write command only write to CPU RAM 1 : ON communication write command write to CPU RAM and EEPROM	ON	OFF	ON	SET5.4
MLNB		Piece linear compensation segment select TRIP : leave setting loop 1~10 : segment select	10	TRIP	TRIP	SET8.4
COMP		Piece linear compare value	USPL	LSPL	LSPL	SET8.4
OFFS		Piece linear offset value	150.0	-150.0	0.0	SET8.4
HBOP		Output percentage of trigger HBA	100.0	0.0	90.0	INP2=4 & ALD1=9
TRCL		Main input TC/RTD zero calibration	9999	0	0	SET2.2
TRCH		Main input TC/RTD span calibration (hex display)	7FFF	0	5FFF	SET2.2
TP_K		reserve	100.0	10.0	15.0	PROG = ON
PVOH		PV bias(for span) $PV = PV \times (PVOH / 5000) + PVOS$	9999	0	5000	SET6.2
PVST		Program execute start address 0 : FULT (execute from current PV, but use segment 1 fully time) 1 : CUTT (execute from current PV,cut time)	CUTT	FULT	FULT	SET8.3

9.14 Fast Level Parameter

Parameter	Symbol	Content	Range		Default	Hide/ Display
			MAX	MIN		
MV.SF		Analog input special function selection 0 : NONE (special function OFF) 1 : SQUA (analog input square) 2 : ROOT (analog input square root) 3 : REVE (analog input reverse) 4 : SQ.RE (analog input square reverse) 5 : RO.RE (analog input square root reverse)	RO.RE	NONE	NONE	INP1= AN1~AN4

10. Functional Descriptions

10.1 PV bias

Description

The FY/FA series controller offers PV bias for input calibration, PV bias functions correct the deviation of each sensor, as well as PV difference between controllers.

Function Diagram

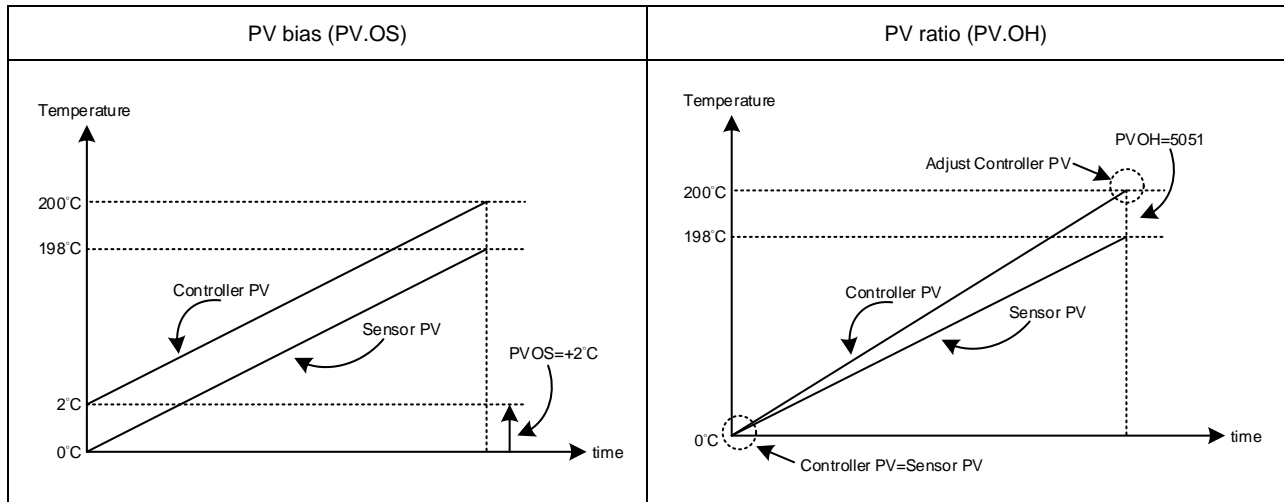

The related parameters of input calibration are as below:

Parameter	Symbol	Content	Range		Default	Level	Hide/Display
			MAX	MIN			
PVOS	<i>PVOS</i>	PV bias(for zero) $PV = PV + PVOS$	199.9	-199.9	0	Level 3	SET6.2
PVOH	<i>PVOH</i>	PV bias(for span) $PV = PV \times (PVOH / 5000) + PVOS$	9999	0	5000	Fast	SET6.2

Examples

PV bias (PVOS) adds bias to the Measured value(PV):

When two controllers measure the temperature of the same type of load, the measured values of the respective characteristics of the sensors are displayed as

Controller A : 200°C Controller B : 195°C

As shown above, Controller B is compensated by PV offset (PVOS) The PV.OS parameter value must be corrected by +5°C. The display value will be changed to 200°C, Same as Controller A, but Controller B will show 5°C at 0°C.

Parameter setting

Level	Parameter	Set value	Description
4	SET6.2	1	Display PVOS
3	PVOS	5	PV adds +5°C
Fast	PVOH	5000	PV ratio unchanging

Example 2

PV ratio (PVOH) is a multiplier to be applied to the measured value(PV):

When two controllers measure the temperature of the same type of load, the measured values of the respective characteristics of the sensors are displayed as

Controller A : 200°C Controller B : 195°C

As shown above, if Controller B is compensated by the PV ratio (PVOH), then the PVOH parameter value is adjusted to display at 200°C. Consistent with Controller A, Controller B will show 0°C at 0°C.

Parameter Setting

Level	Parameter	Set value	Description
4	SET6.2	1	Display PVOS / PVOH
3	PVOS	0	PV bias unchanging
Fast	PVOH	5129	PV ratio=(5129/5000)=1.0258

10.2 Retransmission

Description

The retransmission function of the FY/FA series controller can provide digital values for parameters such as SV or PV etc. Analog signals are transmitted to external devices according to the set range (EX: PLC AI module, inverter, etc.). transmission output signal selectable: 4~20mA, 0~20mA, 0~5V, 0~10V, 1~5V, 2~10V

Function Diagram

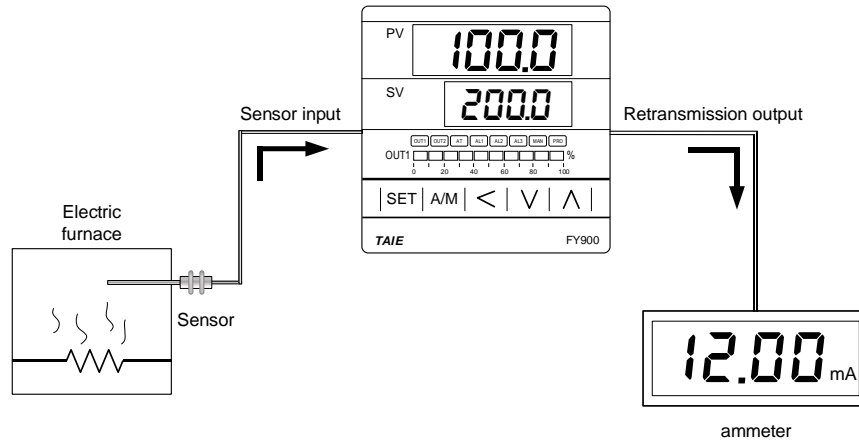

The related parameters of Transmission are as below:

Parameter	Symbol	Content	Range		Default	Level	Hide/Display
			MAX	MIN			
SET9.3	SEEE	0 : Retransmission SV disable 1 : Retransmission SV enable	1	0	0	Level 4	---
SET9.4	SEEE	0 : Retransmission PV disable 1 : Retransmission PV enable	1	0	0	Level 4	---
CLO3	CL03	Retransmission zero calibration	9999	0	0	Level 3	SET5.2
CHO3	CH03	Retransmission span calibration	9999	0	3600	Level 3	SET5.2

Examples

Assume the input range (LSPL & USPL) = -50.0~600.0 retransmit PV

When the PV value is between -50.0 and 600.0, the retransmission signal is based on the PV value, and the linear output analog signal is presented.

When the PV is less than -50.0, the retransmission signal remains at 4mA

When the PV value is greater than 600.0, the retransmission signal remains at 20mA

Parameter setting

Level	Parameter	Set value	Description
3	SET9.4	1	Retransmission PV
3	CLO3	3133	Retransmission signal low point calibration value (each controller calibrate value is different)
3	CHO3	3508	Retransmission signal high point calibration value (each controller calibrate value is different)

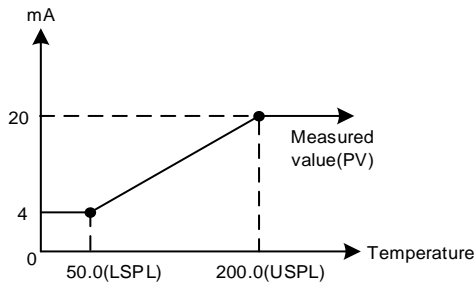

Notes

- To order TRS function, please confirm the type of retransmission output signal and retransmit signal range.
- The user can select the source to be transmitted according to the parameter SET9.4 or SET9.3. The factory default is to retransmit the PV.
- Modify the parameter INP1/UNIT will reset the retransmission range.
- CLO3 & CHO3 are the calibration parameters of the re-transmission signal. It has been calibrated before leaving the factory. do not change this parameter value.
- The user only needs to set SET9.4 or SET9.3, the rest of the parameters will be set & calibrated at the factory.

10.3 Remote SV

Description

Remote SV functions as an analog signal (4~20mA or 0~10V) generated by external devices (EX: PLC AO module, transmitter) to the Remote SV terminal of the controller, to change the SV with a preset range.

Remote SV signal selection: 4~20mA, 0~20mA, 0~5V, 0~10V, 1~5V, 2~10V

Function Diagram

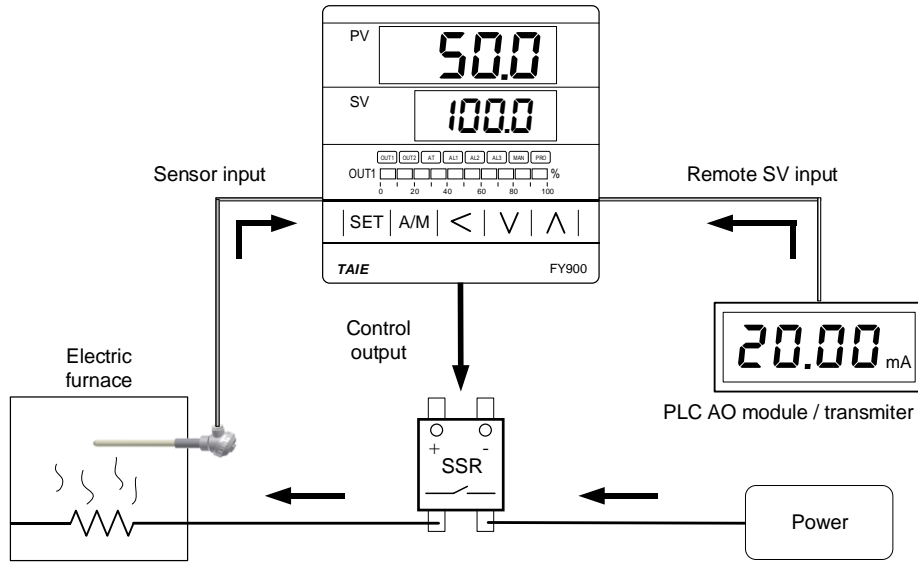

The related parameters of Remote SV are as below:

Parameter	Symbol	Content	Range		Default	Level	Hide/Display
			MAX	MIN			
SET0.3	<i>SEED</i>	0 : Remote SV disable 1 : Remote SV enable	1	0	0	Level 4	---
INP2	<i>INP2</i>	Sub input type selection 0 : none 1 : 10~50mV / 4~20mA / 1~5V / 2~10V (only available in remote SV) 2 : 0~50mV / 0~20mA / 0~5V / 0~10V (only available in remote SV) 3 : valve feedback 4 : CT input	4	0	0	Level 4	---
ANL2	<i>ANL2</i>	Sub input zero calibration	9999	-1999	0	Level 3	SET2.4
ANH2	<i>ANH2</i>	Sub input span calibration (hex display)	0x7FFF	0x0000	0x5FFF	Level 3	SET2.4

Examples

Input signal is K1 and its range is -50.0~600.0. When an external analog signal is input to the Remote SV terminal, the signal will be based on the range presents linear display of SV parameters

When the signal input value is less than 2.4mA, the PV position shows nnn2, indicating that the signal of Remote SV is lower than the lower limit value

When the signal input value is greater than 21.6mA, the PV position shows uuu2, indicating that the signal of Remote SV is higher than the upper limit value

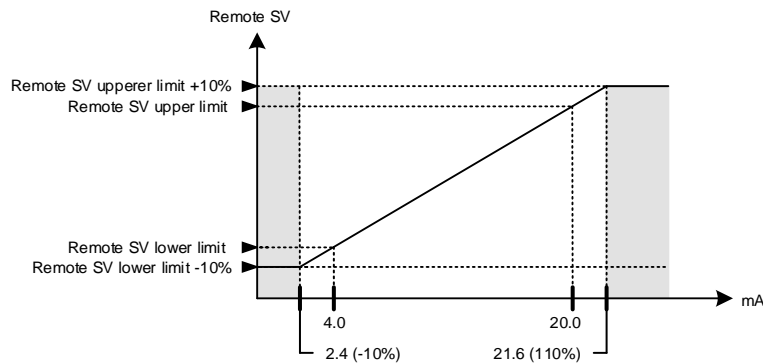

Parameter setting

Level	Parameter	Set value	Description
4	SET0.3	1	Enable Remote SV function
4	INP2	1	Remote SV signal=4-20mA
3	ANL2	744	Remote SV signal low point calibration value (each controller calibrate value is different)
3	ANH2	0x657C	Remote SV signal high point calibration value (each controller calibrate value is different)

Notes

1. To order Remote SV function, please confirm signal type and Remote SV input range first.
2. Modify the parameter INP1 & UNIT will reset the input range
3. The ANL2 and ANH2 are the calibration parameters of Remote SV. It has been calibrated before leaving the factory. Please do not change this parameter.

10.4 Heater Break Alarm

Description

The HBA (Heater-Break-Alarm) function measures the heater current and displays the measured current value on the parameter HBAC upper area so that the heater status can be monitored at any time.

When it is detected that the heater is disconnected or the heater current is abnormally reduced, an alarm message may be immediately output to notify the user.

Function Diagram

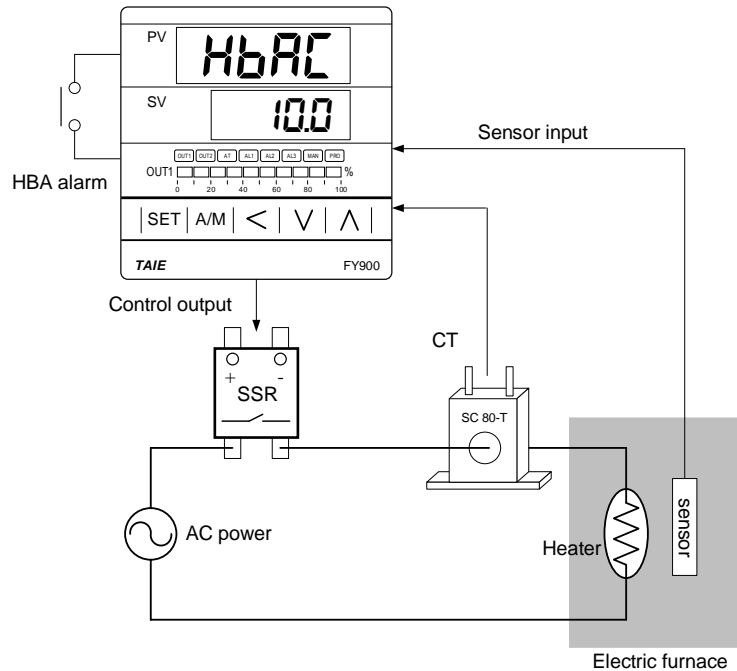

The related parameters of Heater Break Alarm are as below :

Parameter	Symbol	Content	Range		Default	Level	Hide/Display
			MAX	MIN			
*HBAC	<i>HbAC</i>	HBA current setting value Upper : heater current display Down : current setting value unit : ampere(A)	100.0	0.0	1.0	Level 1	INP2=4 & ALD1=9
HBOP	<i>HbOP</i>	Output percentage of trigger HBA	100.0	0.0	90.0	Fast	INP2=4 & ALD1=9

* when ALD1=9 & INP2=4 , original AL1 become HBAC display

HBA operating conditions

1. Heater current is less than the setting of HBAC
2. OUT1 output exceeds HBOP setting value
3. The conditions of 1 & 2 above are established and continue to exceed 20 seconds

Examples

Heating system with SSR as control element, set HBAC=1.0(down display area)

1. The heater current display value HBAC = 0.0(upper display area), when a heater disconnection occurs
→ The heater current is less than the set value of HBAC=1.0. At this time ,condition 1 is satisfied.
2. The heater no longer heats when the heater disconnection occurs, and the gap between the PV and SV will become larger and larger.
→ The manipulated value of OUT1 is also getting larger and larger, and eventually exceeds 90%. At this time ,condition 2 is
3. Satisfied, alarm_1 will be activated when both 1 & 2 conditions are met and continue for more than 20 seconds.

Parameter setting

Level	Parameter	Set value	Description
1	HBAC	1.0	HBA action current (Unit: A)
Fast	HBOP	90.0	When the output exceeds 90.0%
4	INP2	4	CT current input
3	ALD1	9	HBA Alarm
3	ANL2	-12	Current low-point calibration value (each controller calibrate value is different)
3	ANH2	0x4527	Current High-point calibration value (each controller calibrate value is different)

Notes

1. ANL2 & ANH2 is the current signal calibration parameters. It has been calibrated before leaving the factory. do not change these two parameters value.
2. The user only needs to set HBAC & HBOP, the rest of the parameters will be set & calibrated at the factory.
3. CT has two specifications: SC 80-T & SC 100-T. Please check heater wire diameter and specify required CT.

CT Specifications

Item	Specifications	
Model number	SC 80-T	SC 100-T
Turns Ratio	800:1	1000:1
Max. continuous current	80A	100A
Accuracy	3%	5%
Aperture	5.9mm	12.6mm
Dielectric Withstanding Voltage(Hi-pot)	2500Vrms / 1 minute	4000Vrms / 1 minute
Vibration resistance	50 HZ, 98 m/s ²	
Weight	Approx. 12 g	Approx. 30 g

Dimensions (UNIT : mm)

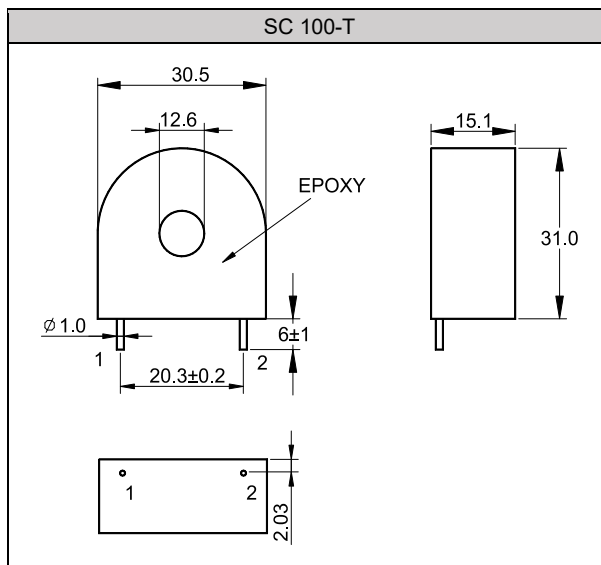
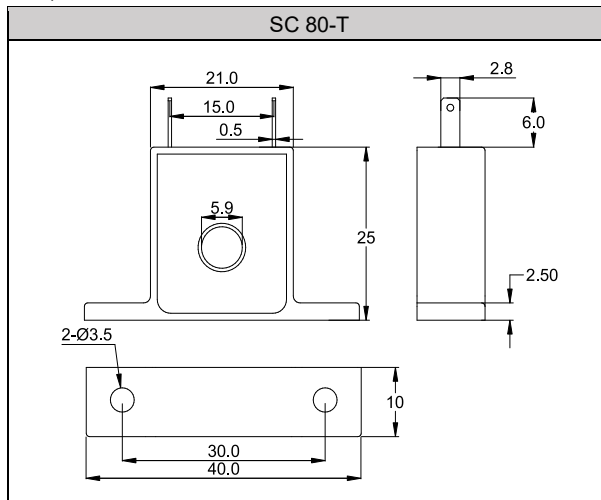

10.5 Dehumidification Function

Description

The FY/FA series controller provides dehumidification function to protect the heater. When the power is turned on, the heater is dehumidified with low power. When the dehumidification is completed, the normal power is output to the heater.

Function Diagram

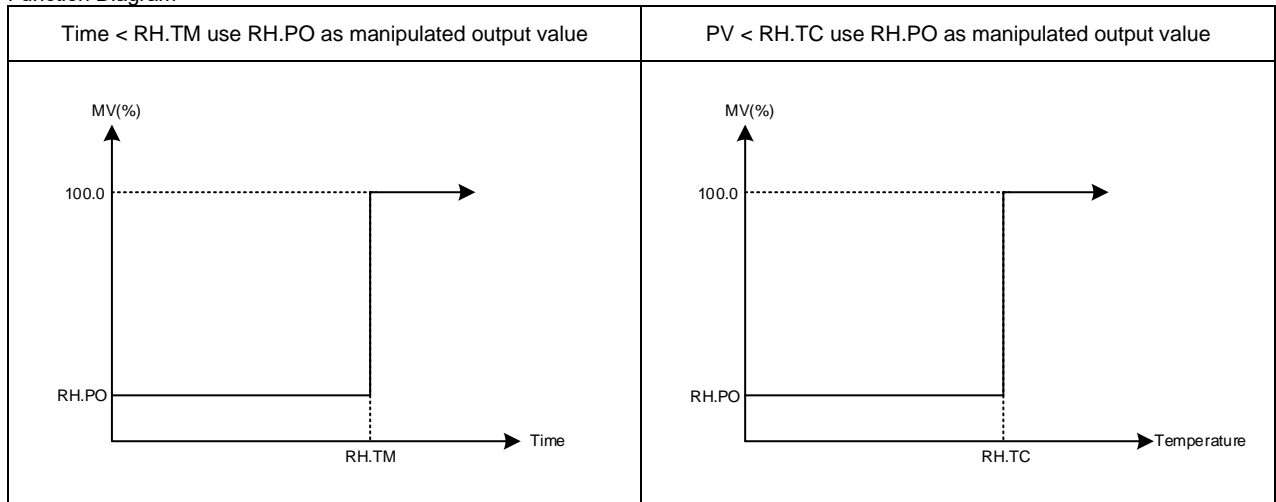

The related parameters of Dehumidification Function are as below:

Parameter	Symbol	Content	Range		Default	Level	Hide/Display
			MAX	MIN			
RH.TC		Dehumidification temperature If PV less than RHTC manipulated value = RHPO	200.0	0.0	125.0	Fast	---
RH.PO		Dehumidification manipulated value 0 : OFF disable dehumidification function Other values : 0.1~100.0 manipulated value	100.0	OFF	OFF	Fast	---
RH.TM		Dehumidification time time format : min.sec	COTI	0.00	15.00	Fast	---

Example

After the controller is turned on, when the PV does not reach 50°C, manipulated value fixed in 20%. When the time exceeds 15 minutes or the PV is greater than 50°C, the controller will produce output of normal PID gain.

Parameter setting

Level	Parameter	Set value	Description
1	SV	100.0	Target temperature
Fast	RH.TC	50.0	Execute de-humidifying function when PV is lower than this temperature
Fast	RH.PO	20.0	When executing dehumidification function the manipulated value fixed in 20%
Fast	RH.TM	15.00	Max dehumidification function time

Notes

- For use in heating mode only (OUD=HEAT)
- SV must be greater than PV (SV>PV)

10.6 Motor Valve Control

Description

FY/FA motor valve control function converts the control output value of the controller into the corresponding signal to control a motor driven valve and then performs temperature control of a controlled object by regulating fluid flow.

Function Diagram

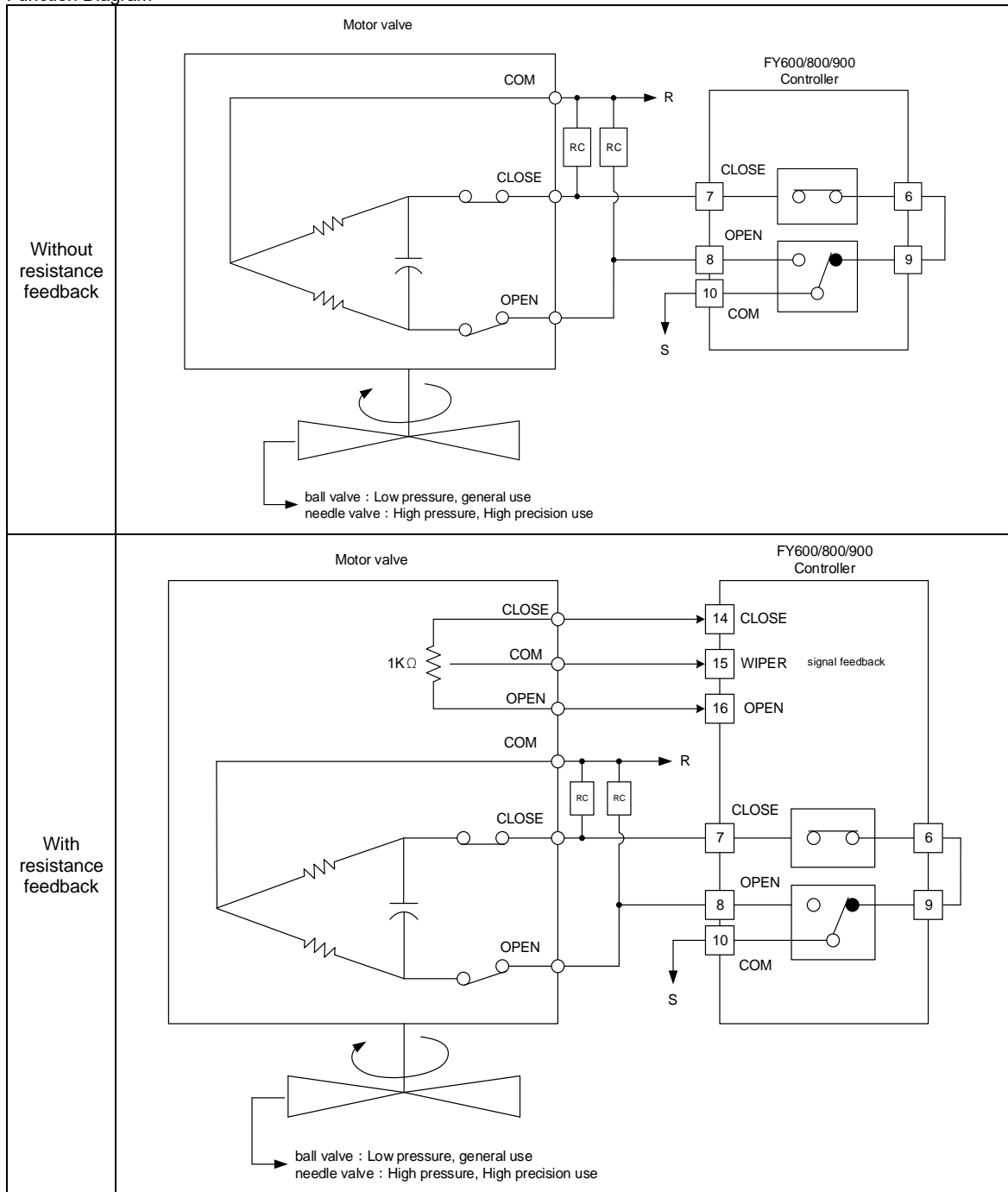

Description of function

When the feedback resistance is provided

1. Adjusting valve position automatically
2. The valve position can be manually changed.
3. Force the controller to switch to no feedback resistance control mode when feedback resistance input breaks
4. High/Low limit of valve position can be set.

When the feedback resistance is not provided:

1. Control motor operation can be restricted by the parameter "OUTL".
2. The UP/DOWN key is used to output opening or closing signal in manual mode
 - 2.1 UP key(open-side) : While the UP key is being pressed, open-side output (OUT1) is output continuously.
Releasing the UP key turns off the output on the open-side to hold the opened state at that time.
 - 2.2 DOWN key(close-side) : While the DOWN key is being pressed, close-side output (OUT2) is output continuously.
Releasing the DOWN key turns off the output on the closed-side to hold the opened state at that time.

The related parameters of motor valve control function are as below:

Parameter	Symbol	Content	Range		Default	Level	Hide/Display
			MAX	MIN			
PV2		Valve opening monitor	100.0	0.0	---	Fast	OUTY=2 & SET7.1
OUTY		Hardware drive selection 0 : single output control 1 : dual output control 2 : valve control with feedback 3 : valve control without feedback selection 4 : single phase angle control	4	0	0	Level 4	---
INP2		Sub input type selection 0 : none 1 : 10~50mV / 4~20mA / 1~5V / 2~10V (only available in remote SV) 2 : 0~50mV / 0~20mA / 0~5V / 0~10V (only available in remote SV) 3 : valve feedback 4 : CT input	4	0	0	Level 4	---
PMAC		Automatic valve position adjustment 0 : OFF stop automatic adjust 1 : ON start automatic adjust 2 : E_PB Valve position determined by external button	E_PB	OFF	OFF	Fast	OUTY=2
RUCY		Motor valve traveling time Time unit : second	150	5	5	Fast	OUTY = 2 or 3
CYT1		Motor valve action interval time. Time unit : second	10	1	5	Fast	OUTY = 2 or 3
HYSM		Motor valve action main adjustment unit : percentage	5.0	0.0	1.0	Fast	OUTY = 2 or 3
HYS1		Motor valve action sub adjustment unit : percentage	HYSM	0	0.5	Fast	OUTY = 2 or 3

Motor valve Initial Setting

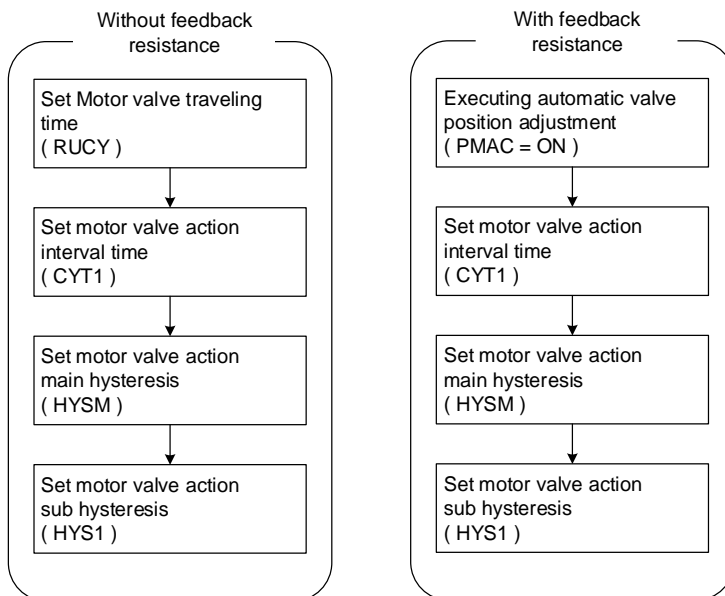

1. Executing automatic valve position adjustment

Parameter	Symbol	Content	Default	Level
PMAC		Automatic valve position adjustment 0 : OFF stop automatic adjust 1 : ON start automatic adjust 2 : E_PB Valve position determined by external button	OFF	Fast

The motor valve low position(ANL2) and high position(ANH2) are calibrated and the travel time from completely open to completely closed is set automatically

When the measurement has been complete the setting of the parameter will change to OFF."PMER" will be display if any of following errors occurs during execution.If an error occur check the wiring and other factors and execute automatic valve position adjustment again.

2. Setting motor valve traveling time

Parameter	Symbol	Content	Default	Level
RUCY		Motor valve traveling time Time unit : second	5	Fast

With feedback resistance mode

Executing automatic valve position adjustment will get RUCY setting value automatically

Without feedback resistance mode

Check the motor valve specification and setting the RUCY value of a manually

3. Setting valve action interval time

Parameter	Symbol	Content	Default	Level
CYT1		Motor valve action interval time. Time unit : second	5	Fast

EX1 : Setting CYT1=5, after executing current valve action, If the controller calculates that the valve needs to be closed for 2 seconds, controller will delay 5 seconds before performing close valve action

EX2 : Setting CYT1=7, after executing current valve action, If the controller calculates that the valve needs to be open for 2 seconds, controller will delay 7 seconds before performing open valve action

4. Setting motor valve action main adjustment

Parameter	Symbol	Content	Default	Level
HYSM		motor valve action main adjustment unit : percentage	1.0	Fast

When error% accumulates to the set value of HYSM the controller will drive motor valve to eliminate this error%

EX1 : set HYSM =0.5, when error% accumulates to 0.5 the controller will drive motor valve to eliminate this error%

EX2 : set HYSM =1.0, when error% accumulates to 1.0 the controller will drive motor valve to eliminate this error%

The smaller the set value of this parameter, the more frequent the valve action, the more precise the control, but it will also affect the valve life, proper HYSM setting reduces valve operating frequency to protect valve life

5. Setting motor valve action sub adjustment

Parameter	Symbol	Content	Default	Level
HYS1		motor valve action sub adjustment unit : percentage	0.5	Fast

When the error% accumulates to the set value of HYSM, the controller will drive the valve to eliminate the set value of HYS1

EX1 : set HYSM =0.5, HYS1 =0.3, when error% accumulates to 0.5% the controller will drive motor valve to eliminate 0.3%

EX2 : set HYSM =1.0 · HYS1 =0.5, when error% accumulates to 1.0% the controller will drive motor valve to eliminate 0.5%

6. Setting motor valve high/low limit in resistance feedback control mode

Parameter	Symbol	Content	Default	Level
MOLL		low limit of valve position	0.0	Fast
MOLH		high limit of valve position	100.0	Fast

EX1 : if you want set 20% low limit of valve position, setting MOLL=20.0

EX2 : if you want set 80% high limit of valve position, setting MOLH=80.0

Notes

1. The lowest valve position and the highest valve position are automatically written into ANL2 & ANH2 after executing automatic valve position adjustment
2. When performing automatic valve position adjustment(PMAC=ON), please make sure that the fuel is closed
3. When the controller detects that the feedback resistance is disconnected, it will automatically switch to no feedback control mode and PV area show "PMER" message
4. It is recommended to install spark killer at the relay junction to prolong the service life of the relay.

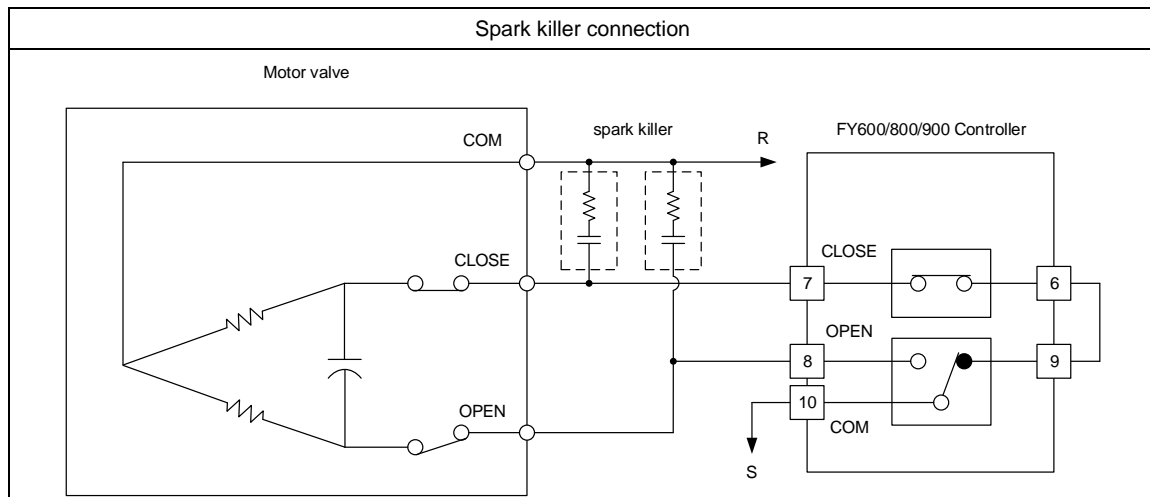

10.7 RAMP & SOAK

Description

The FY/FA series controller provides a single ramp and soak function, after booting completed, the SV starts to increase according to the set value of RAMP. when the soak condition is met the SOAK function will be executed according to the set value of SOAK, and driving the output and alarm to ON or OFF after the SOAK time is executed finish.

The related parameters of ramp and soak function are as below:

Parameter	Symbol	Content	Range		Default	Level	Hide/Display
			MAX	MIN			
SOAK (AL1)		Alarm1 soak time Time format : hr.min	99.59	0.00	0.10	Level 1	ALD1=10 or ALD1=19
SOAK (AL2)		Alarm2 soak time Time format : hr.min	99.59	0.00	0.10	Level 1	ALD2=10 or ALD2=19
SOAK (AL3)		Alarm3 soak time Time format : hr.min	99.59	0.00	0.10	Level 1	ALD3=10
RAMP (AL3)		The rate of change during an SV ramp format : °C / minute	99.99	-19.99	99.99	Level 1	ALD3=9

- ※ when ALD1=10 or 19, original AL1 become SOAK display
- when ALD2=10 or 19, original AL2 become SOAK display
- when ALD3=9, original AL3 become RAMP display

Parameter	Set value	Description
ALDX	10 (SOAK_A)	Boot completed, the alarm is ON. When PV ≥ target SV start the soak timer, alarm and control function are turned OFF in soak time finish (In this mode, the time format is fixed to "hour.minute")
	19 (SOAK_B)	Boot completed, the alarm is OFF. when PV ≥ target SV start the soak timer, alarm is turned ON and the control function keep ON in soak time finish (In this mode, the time format is fixed to "hour.minute")

X : 1 / 2(SOAK function available in alarm1 or alarm2)

Example(1) Single RAMP+SOAK_A (ALD3=9 + ALD1=10)

Boot completed, the alarm1 is ON, SV rise 5.00°C per minute. when the PV reaches 100 °C, the temperature is kept for 10 minutes. after 10 minutes alarm1 and control function are turned OFF

Parameter setting

Level	Parameter	Set value	Description
1	SV	100.0	Target temperature
4	SET2.1	1	Display AL3
4	SET4.1	1	Display ALD3
3	ALD1	10	AL1 as soak timer
3	ALD3	9	Enable RAMP function
1	SOAK(AL1)	0.10	Soak for 10 minutes
1	RAMP(AL3)	5.00	5.00°C rise per minute

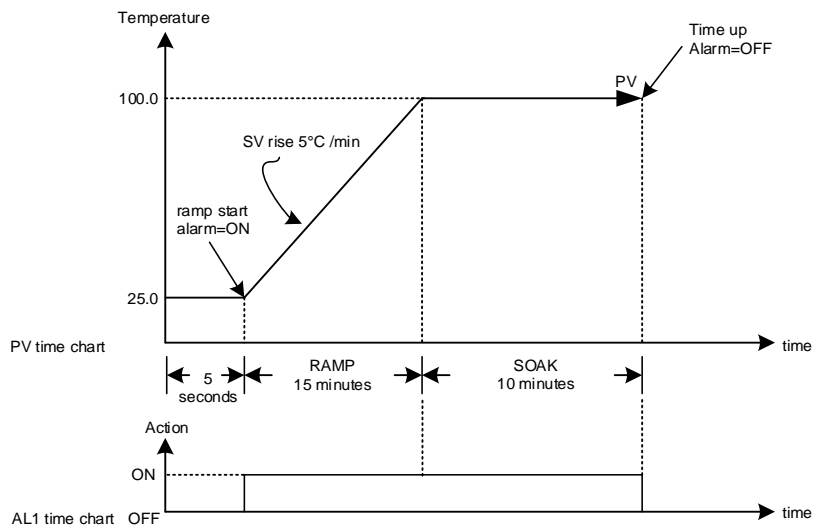

Example(2) Single RAMP+SOAK_B (ALD3=9 + ALD1=19)

Boot completed, the alarm1 is OFF, SV rise 5.00°C rise per minute. when the PV reaches 100 °C, the temperature is kept for 10 minutes. after 10 minutes alarm is turned ON and the control function keep ON

Parameter setting

Level	Parameter	Set value	Description
1	SV	100.0	Target temperature
4	SET2.1	1	Display AL3
4	SET4.1	1	Display ALD3
3	ALD1	19	AL1 as soak timer
3	ALD3	9	Enable RAMP function
1	SOAK(AL1)	0.10	Soak for 10 minutes
1	RAMP(AL3)	5.00	5.00°C rise per minute

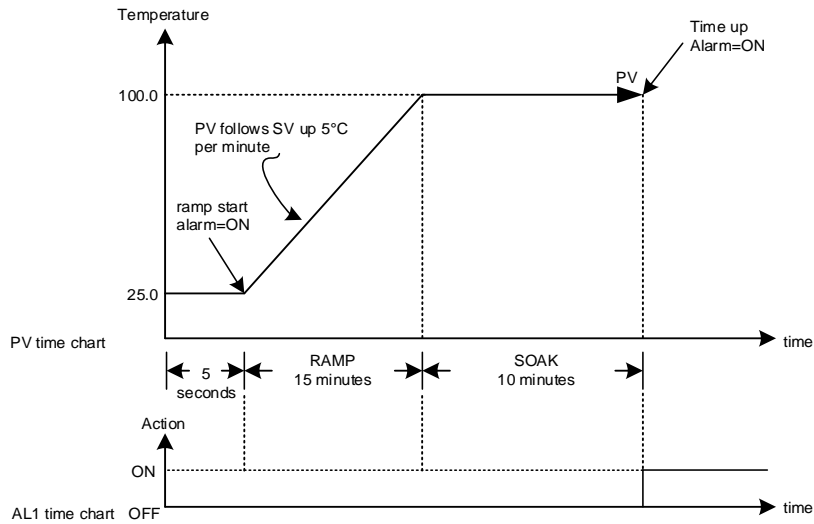

Example(3) only use SOAK_A (ALD1=10)

Boot completed, the alarm1 is ON, and the PV is directly controlled at 100 °C. when the PV reaches 100 °C, the temperature is kept for 10 minutes. after 10 minutes alarm1 and control function are turned OFF

Parameter setting

Level	Parameter	Set value	Description
1	SV	100.0	Target temperature
3	ALD1	10	AL1 as soak timer
1	SOAK(AL1)	00.10	Soak for 10 minutes

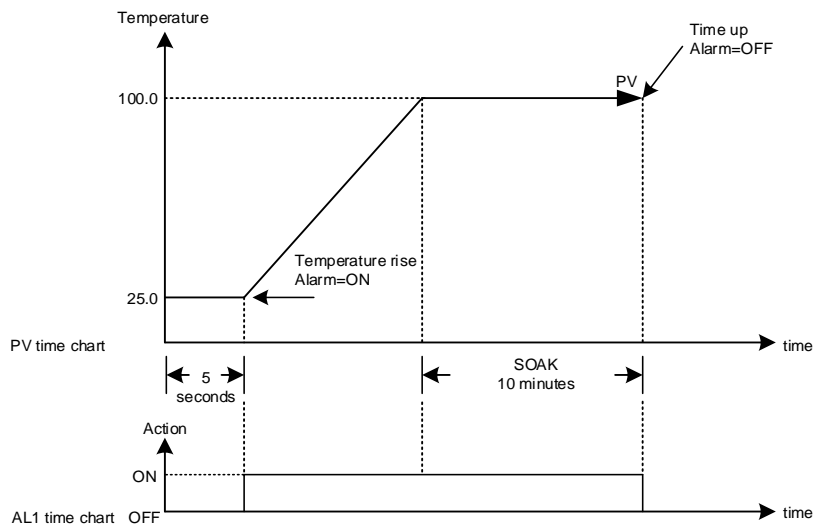

Example(4) only use SOAK_B (ALD1=19)

Boot completed, the alarm1 is OFF, and the PV is directly controlled at 100 °C. when the PV reaches 100 °C, the temperature is kept for 10 minutes. after 10 minutes alarm is turned ON and the control function keep ON

Parameter setting

Level	Parameter	Set value	Description
1	SV	100.0	Target temperature
3	ALD1	10	AL1 as soak timer
1	SOAK(AL1)	00.10	Soak for 10 minutes

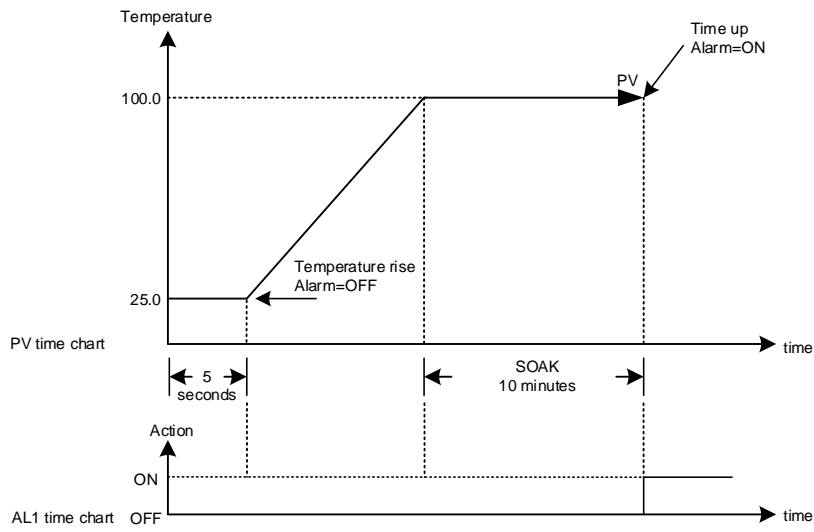

10.8 Proportional Control

Description

Proportional control is one of the simplest ways to control method, controller manipulated value proportional to input error signal, this chapter explains how to set related parameters.

Function Diagram

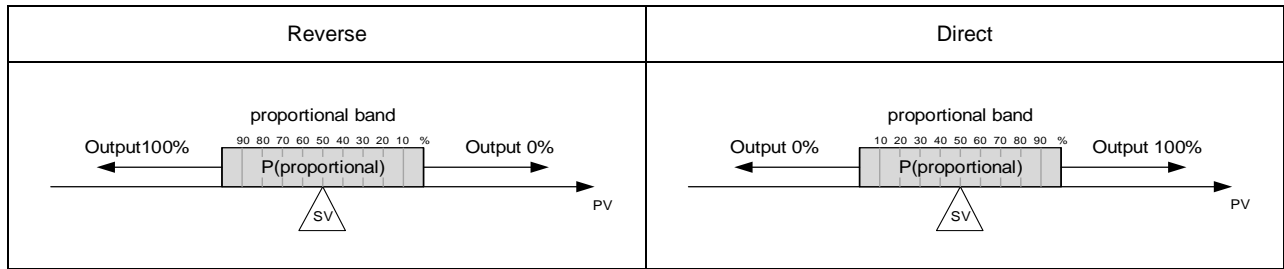

The related parameters of proportional control are as below:

Parameter	Symbol	Content	Range		Default	Level	Hide/Display
			MAX	MIN			
SV	---	Set value	USPL	LSPL	---	Level 1	---
P1		Main output proportional band 0.0 : ON/OFF control Other values : proportional band setting value	200.0	0.0	3.0	Level 2	---
OUT		Control action selection 0 : HEAT reverse action 1 : COOL direct action	COOL	HEAT	HEAT	Level 3	SET7.2

Setting step

1. Select control action
2. Determine the proportional band
3. Set SV, $SV = (\text{proportional band maximum} + \text{proportional band minimum}) / 2$
4. Full range = (Range maximum – range minimum)
5. Calculate $P = ((\text{proportional band maximum} - \text{proportional band minimum}) / \text{Full range}) \times 100$

Example 1 :

INP1 = K1(-50.0~600.0) when PV in the range of 90.0 ~ 100.0 output proportional(decrease) SV = ? P = ?

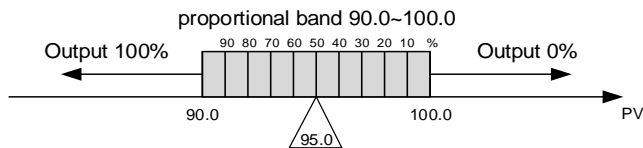

1. OUD = HEAT(Reverse)
2. Proportional band → 90.0~100.0
3. $SV = (\text{proportional band maximum} + \text{proportional band minimum}) / 2$
→ $(100.0 + 90.0) / 2 = 95.0$
4. Full range = (Range maximum – range minimum)
→ $600.0 - (-50.0) = 650.0$
5. $P = ((\text{proportional band maximum} - \text{proportional band minimum}) / \text{Full range}) \times 100$
→ $((100.0 - 90.0) / 650.0) \times 100 = 1.5384(\text{approx } 1.5)$

Example 2 :

INP1 = AN4(0.0~100.0) when PV in the range of 0.0 ~ 100.0 output proportional(increase) SV = ? P = ?

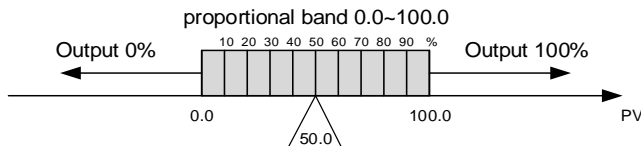

1. OUD = COOL(Direct)
2. Proportional band → 0.0~100.0
3. $SV = (\text{proportional band maximum} + \text{proportional band minimum}) / 2$
→ $(100.0 + 0.0) / 2 = 50.0$
4. Full range = (Range maximum – range minimum)
→ $100.0 - 0.0 = 100.0$
5. $P = ((\text{proportional band maximum} - \text{proportional band minimum}) / \text{Full range}) \times 100$
→ $((100.0 - 0.0) / 100.0) \times 100 = 100.0$

Notes

1. When using proportional control I1 and D1 must be set to 0
2. Full range please check Chapter 4 "Input Range Table"
3. Only using proportional control will eventually have a steady state error

10.9 Master-Slave communication

Description

Transmission master controller SV to slave controller SV, all slave controller SV can be consistent

Wiring

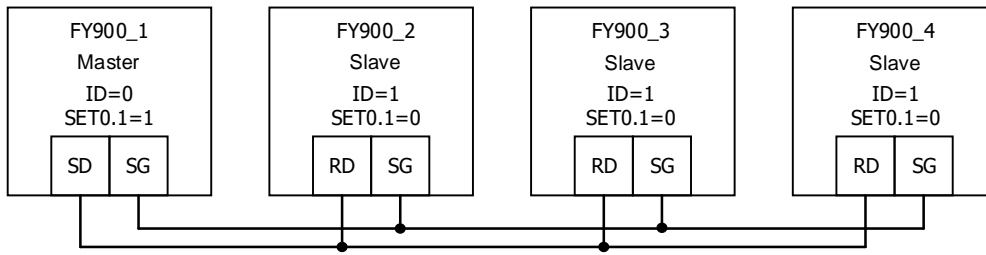

The related parameters of master-slave communication are as below:

Parameter	Symbol	Content	Range		Default	Level	Hide/Display
			MAX	MIN			
RATE	<i>9999</i>	Slave SV rate RATE SV = SV x (RATE/9999)	9999	0	9999	Level 1	SET2.1 & SET0.2
PSL	<i>TAIE</i>	Protocol selection 0 : TAIE 1 : RTU (Please refer to communication manual)	RTU	TAIE	TAIE	Level 3	SET5.4
BITS	<i>O_81</i>	Data format 0 : O_81 (parity bit=odd, stop bit=1) 1 : O_82 (parity bit=odd, stop bit=2) 2 : E_81 (parity bit=even, stop bit=1) 3 : E_82 (parity bit=even, stop bit=2) 4 : N_81 (parity bit=none, stop bit=1) 5 : N_82 (parity bit=none, stop bit=2)	N_82	O_81	O_81	Level 3	SET5.4
IDNO	<i>1</i>	Controller station	254	0	1	Level 3	SET5.4
BAUD	<i>96</i>	Baud rate 0 : 24(2400) 1 : 48(4800) 2 : 96(9600) 3 : 192(19200) 4 : 384(38400) 5 : 576(57600) 6 : 1152(115200) bps	1152	24	96	Level 3	SET5.4
SET0.1	<i>0</i>	0 : TTL Communication (Slave) 1 : TTL Communication (Master)	1	0	0	Level 4	---
SET0.2	<i>0</i>	0 : RATE hide 1 : RATE display	1	0	0	Level 4	---

Master controller setting step

1. IDNO= 0, PSL= TAIE
2. BITS= O_81, BAUD= 96
3. SET0.1= 1
4. SET0.2= 0
5. After completing the above steps, master controller start to transmit SV to slave controller SV

Slave controller setting step

1. IDNO= 1, PSL= TAIE
2. BITS= O_81, BAUD= 96
3. SET0.1= 0
4. SET0.2= 1
5. RATE= 9999
6. After completing the above steps, slave controller start to receive master controller SV

Notes

1. Afer adding master-slave communication, RS-485 communication not available
2. Master-slave communication only available in TAIE protocol(PSL= TAIE)
3. Master controller does not use parameter RATE, to attenuate the SV received by slave controller just adjust parameter RATE
4. Master controller can connect up to 10 slave controllers, and the wiring between every controller should not exceed 1 meter.

10.10 Piece Linear Compensation

Description

When the analog input signal source is nonlinear, using piece linear compensation method to compensate this signal, make it linearity

The related parameters of piece linear compensation are as below:

Parameter	Symbol	Content	Range		Default	Level	Hide/Display
			MAX	MIN			
MLNB		Piece linear compensation segment select TRIP : leave setting loop 1~10 : segment select	10	TRIP	TRIP	Fast	SET8.4
COMP		Piece linear compare value	USPL	LSPL	LSPL	Fast	SET8.4
OFFS		Piece linear offset value	150.0	-150.0	0.0	Fast	SET8.4
SET8.4		0 : MLNB, COMP, OFFS hide 1 : MLNB, COMP, OFFS display	1	0	0	Level 4	---
SET9.1		0 : Disable piece linear compensation 1 : Enable piece linear compensation	1	0	0	Level 4	---

Edit flow-chart

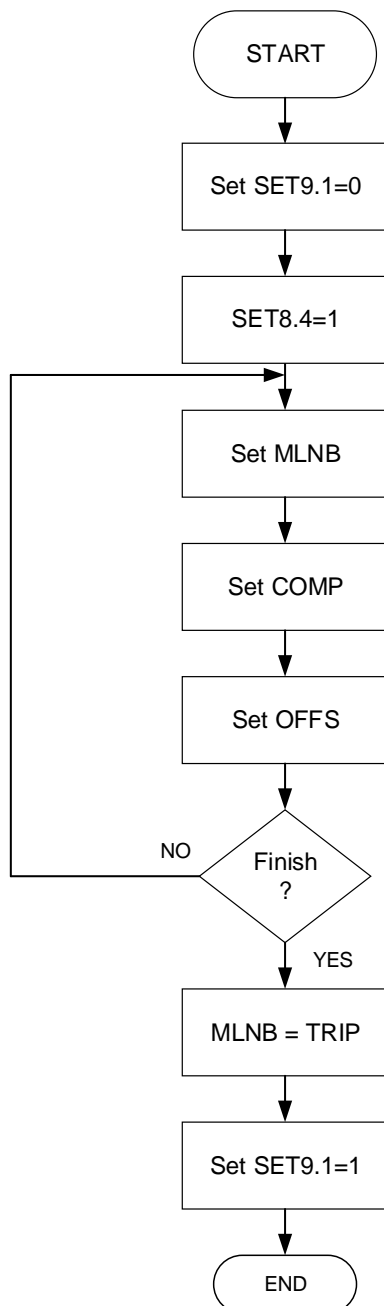

Set MLNB

Parameter	LED display	Description	Default	Level
MLNB		Piece linear compensation segment select TRIP : leave setting loop 1~10 : segment select	TRIP	Fast

When MLNB≠TRIP the display loop in MLNB → COMP → OFFS

When MLNB=TRIP leave piece linear compensation parameter loop

Set COMP

Parameter	LED display	Description	Default	Level
COMP		Piece linear compensation compare value	LSPL	Fast

When non-linear signal value within the set value of COMP, it needs to be compensated.

First COMP set value=LSPL

First COMP set value=USPL

Set OFFS

Parameter	LED display	Description	Default	Level
OFFS		Piece linear compensation offset value	0.0	Fast

When non-linear signal value within the set value of COMP, OFFS use for increase or decrease original non-linear signal

Before the function starts

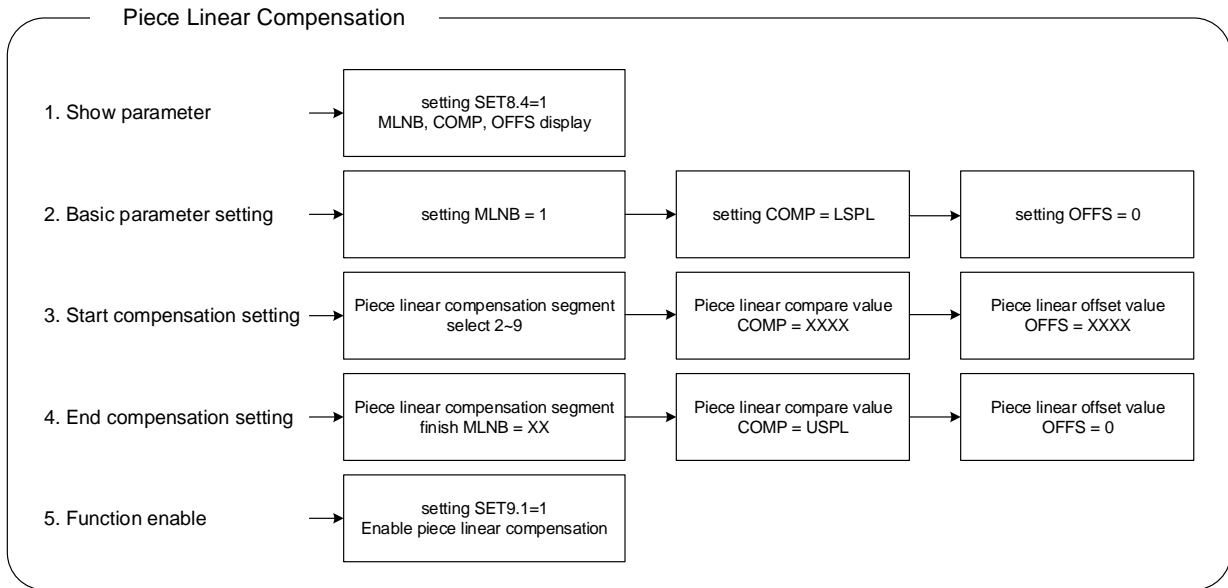

Example1

Assume signal source is a nonlinear signal within 320 °C, and the controller is set to correct at three temperature points.

- (1) When the temperature is 95°C, it needs to be corrected by +5°C.
- (2) When the temperature is 185°C, it needs to be corrected by +15°C.
- (3) When the temperature is 320°C, it needs to be corrected by +30°C.

- Step 1: Set SET8.4=1 and SET9.1=0
- Step 2: Set MLNB = 1, COMP = LSPL, OFFS = 0
- Step 3: set MLNB = 2, COMP = 95, OFFS = 5
- Step 4: Set MLNB = 3, COMP = 185, OFFS = 15
- Step 5: Set MLNB = 4, COMP = 320, OFFS = 30
- Step 6: Set MLNB = 5, COMP = USPL, OFFS = 0
- Step 7: Set MLNB = TRIP and SET9.1=1

Example2

Input signal 4~20mA, range 0~5000, the input signal is nonlinear (as shown in the figure below), use 10 points piece linear compensation.

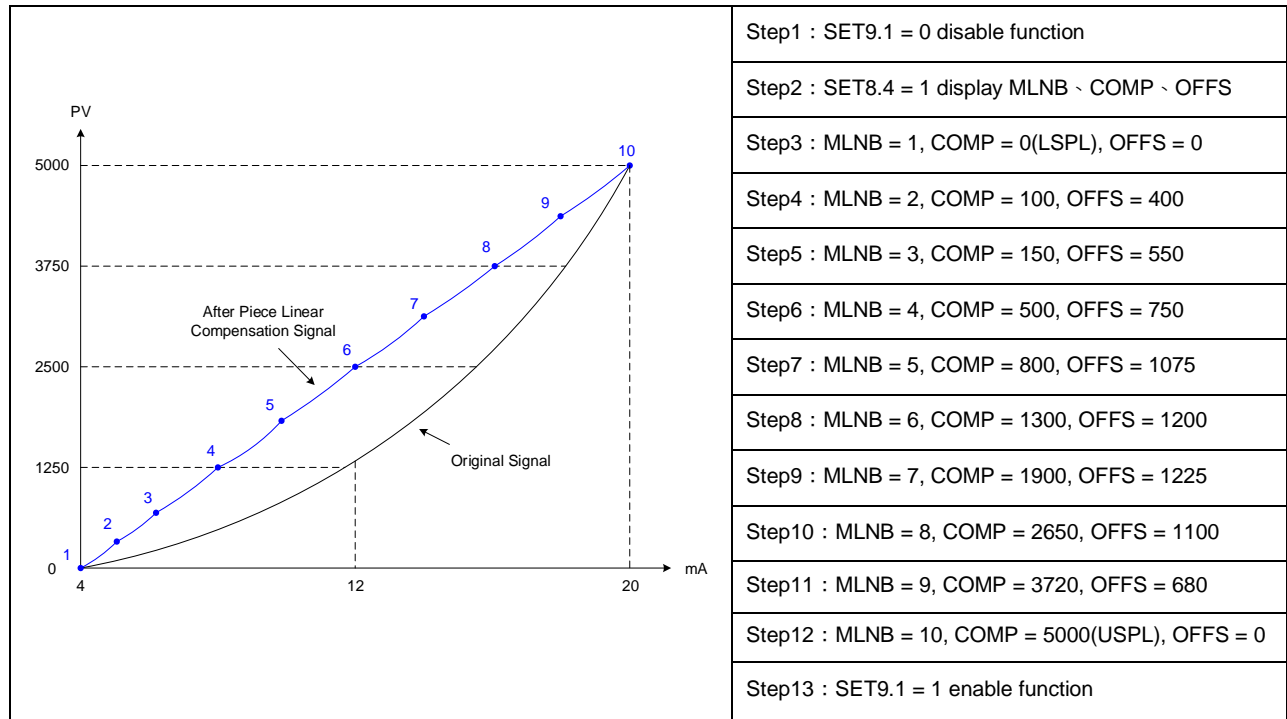

Step1 : SET9.1 = 0 disable function
Step2 : SET8.4 = 1 display MLNB \ COMP \ OFFS
Step3 : MLNB = 1, COMP = 0(LSPL), OFFS = 0
Step4 : MLNB = 2, COMP = 100, OFFS = 400
Step5 : MLNB = 3, COMP = 150, OFFS = 550
Step6 : MLNB = 4, COMP = 500, OFFS = 750
Step7 : MLNB = 5, COMP = 800, OFFS = 1075
Step8 : MLNB = 6, COMP = 1300, OFFS = 1200
Step9 : MLNB = 7, COMP = 1900, OFFS = 1225
Step10 : MLNB = 8, COMP = 2650, OFFS = 1100
Step11 : MLNB = 9, COMP = 3720, OFFS = 680
Step12 : MLNB = 10, COMP = 5000(USPL), OFFS = 0
Step13 : SET9.1 = 1 enable function

Notes

1. The Piece Linear Compensation function must be enabled (SET9.1=1) when MLNB, COMP, OFFS are set, otherwise the controller may display an error message.
2. Regardless of the number of use segments, the first segment COMP must be equal to LSPL, the last segment COMP must be equal to USPL.

10.11 Auto-tuning and Startup tuning

Description



Auto-tuning

When AT is executed, the optimum PID constants for the SV at that time are set automatically. A method (called the limit cycle method) for forcibly changing the manipulated variable and finding the characteristics of the control object is employed.

Startup tuning

As simple auto-tuning, the PID values can be found in a short time without disturbing controllability for controlled systems with slow response at power ON.

The related parameters of Auto-tuning and Startup tuning function are as below:

Parameter	Symbol	Content	Range		Default	Level	Hide/Display
			MAX	MIN			
AT		Auto-tuning execute selection 0 : NO (PID control) 1 : YES (execute auto-tuning) 2 : PR.TU (Startup tuning, execute once) 3 : PRTU (Startup tuning, execute always when reboot)	PRTU	NO	NO	Level 1	SET1.2
AT.VL		Auto-tuning offset value execute auto-tuning in (SV-ATVL) point	100.0	-100.0	0.0	Level 2	---

Auto-tuning diagram

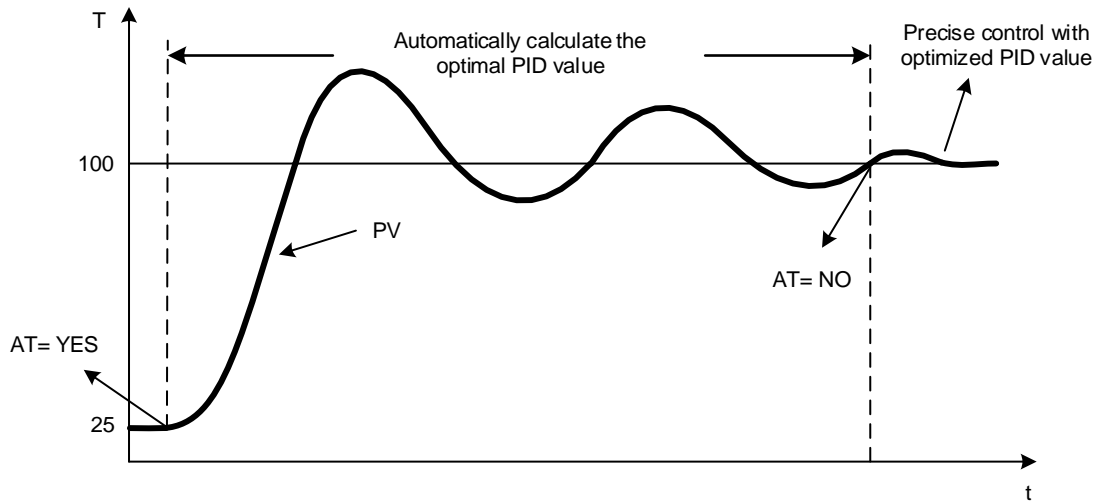

Auto-tuning execution flow chart

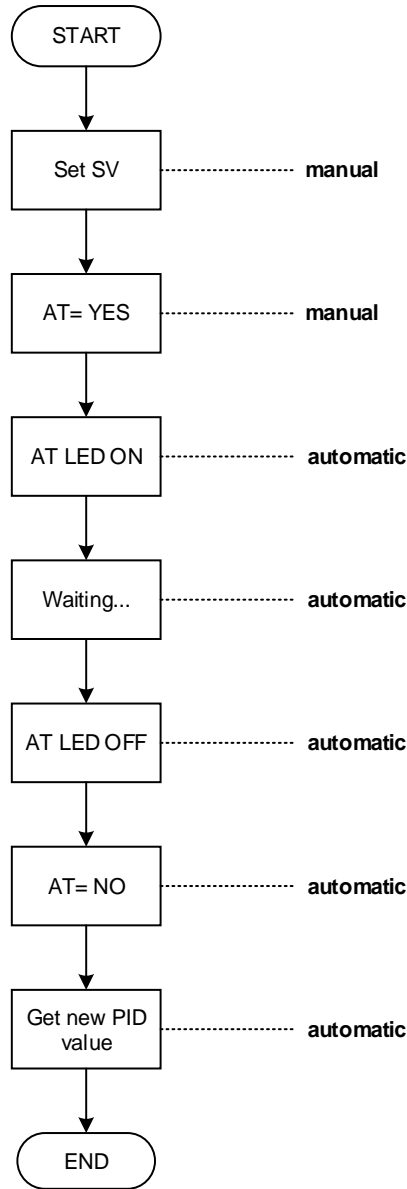

Notes

1. During the execution of auto-tuning, PV will change significantly, do not production during this period
2. During the execution of auto-tuning, please release the function of limiting the output percentage first(set OUTL=100.0)
3. If the alarm terminal link to output terminal, please release it before the execution of auto-tuning.
4. if execute auto-tuning over 2 hours, the controller will return to the control state and display the auto-tuning failure message (AUTF)
5. If the system components (e.g. heater, sensor...) are replaced, please execute the auto-tuning again
6. Auto-tuning can be used for heating or cooling equipment
7. Perform auto-tuning on the dual-output controller, the PID values on the heating side and cooling side will be updated at the same time
8. Can perform auto-tuning at any temperature

Startup tuning diagram

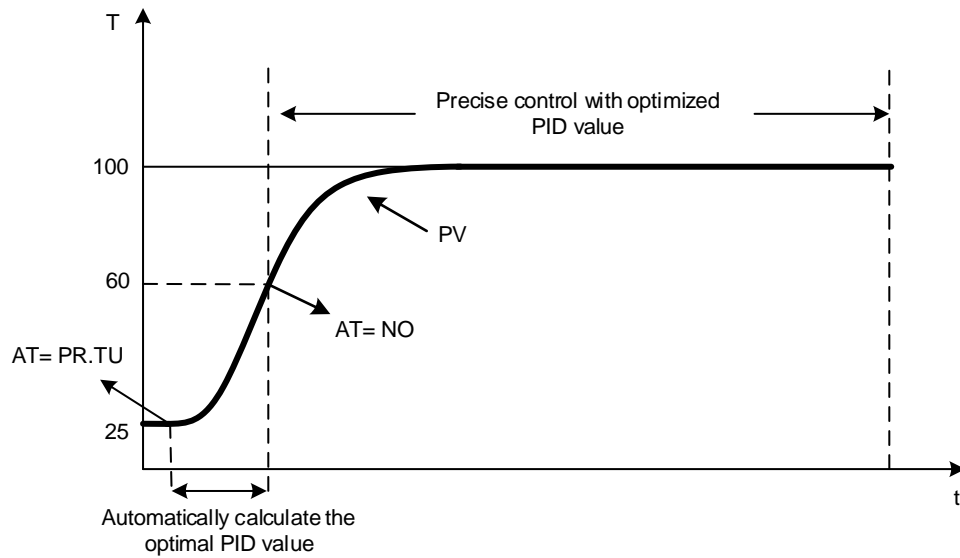

Notes

1. When executing the startup tuning, there is no AT led indicator, when $PV > (SV \times 0.6)$, the startup-tuning will be completed.
2. The startup tuning only available in heating equipment, can't be used in cooling equipment
3. Startup tuning only available in single output controller, and can't be used in dual output controller
4. The gap between SV and PV must be greater than full range $\times 0.06$ before the startup tuning is started
e.g. $K1 = -50.0 \sim 600.0$, full range = 650.0 (650.0×0.06) = 39
 $PV = 25.0$, SV must be greater than $64(25+39)$ startup tuning can't be action
5. Please perform the startup tuning when the system is not heated and the PV is at room temperature

10.12 ON / OFF Control

Description

In ON/OFF control, the output is turned on or off depending on the measured value (PV) whether it is above or below the Set value (SV), user can set a hysteresis zone to prevent turned on and off too frequently for a small change of temperature.

Function Diagram (single output, heat mode)

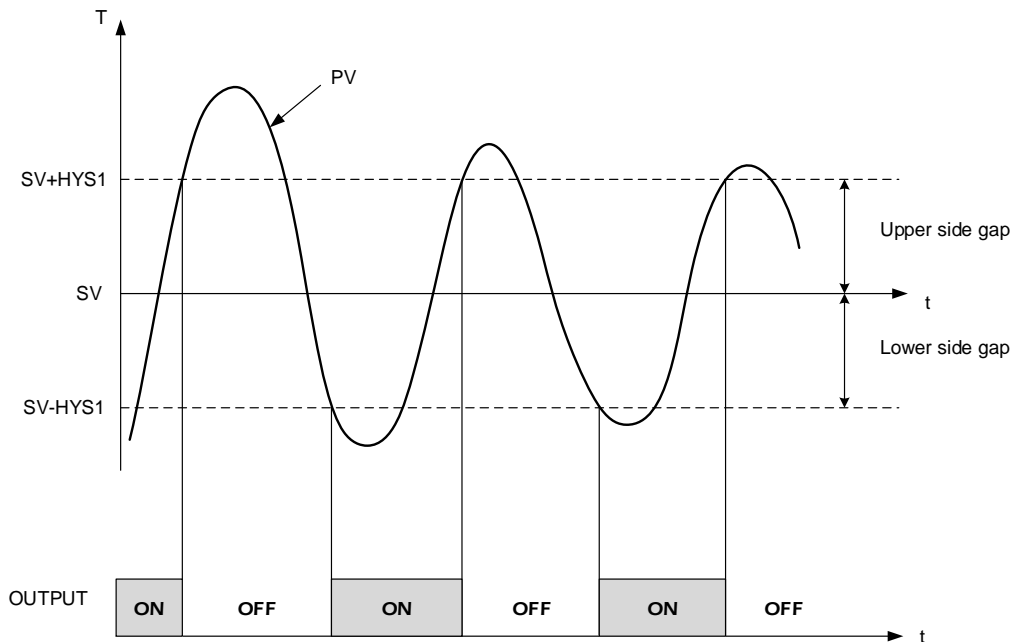

The related parameters of ON/OFF control are as below:

Parameter	Symbol	Content	Range		Default	Level	Hide/Display
			MAX	MIN			
P1	88.88	Main output proportional band 0.0 : ON/OFF control Other values : proportional band setting value	200.0	0.0	3.0	Level 2	---
HYS1	88.88	Hysteresis for main output on/off control use(when P1 = 0.0 appear)	100.0	-100.0	1.0	Level 2	P1 = 0.0
P2	88.88	Sub output proportional band 0.0 : ON/OFF control Other values : proportional band setting value	200.0	0.0	3.0	Level 2	OUTY = 1
HYS2	88.88	Hysteresis for sub output on/off control use(when P2 = 0.0 appear)	100.0	-100.0	1.0	Level 2	P2 = 0.0
GAP1	88.88	Control gap (for main output)	1000	-1000	0	Level 2	OUTY = 1
GAP2	88.88	Control gap (for sub output)	1000	-1000	0	Level 2	OUTY = 1
OD	88.88	Control action selection 0 : HEAT reverse action 1 : COOL direct action	COOL	HEAT	HEAT	Level 3	SET7.2

Example(1)

single output, heat mode

Description	When $PV \leq 95.0^{\circ}\text{C}$ OUT1 : ON · When $PV \geq 105.0^{\circ}\text{C}$ OUT1 : OFF
Formula	$PV \geq (SV + HYS1) \rightarrow \text{OUT1 OFF}$ $PV \leq (SV - HYS1) \rightarrow \text{OUT1 ON}$
diagram	
Parameter setting	SV=100.0 P1=0.0 HYS1=5.0 OD=HEAT

Example(2)
single output, cool mode

Description	When $PV \geq 20.0^{\circ}\text{C}$ OUT1 : ON · When $PV \leq 10.0^{\circ}\text{C}$ OUT1 : OFF
Formula	$PV \geq (SV + HYS1) \rightarrow \text{OUT1 ON}$ $PV \leq (SV - HYS1) \rightarrow \text{OUT1 OFF}$
diagram	
Parameter setting	SV=15.0 P1=0.0 HYS1=5.0 OUD=COOL

Example(3)
dual output(OUT1 : heat mode, OUT2 : cool mode)

Formula	heat side	$PV \geq (SV + GAP1) \rightarrow \text{OUT1 OFF}$ $PV < (SV + GAP1 - HYS1) \rightarrow \text{OUT1 ON}$
	Cool side	$PV \leq (SV + GAP2) \rightarrow \text{OUT2 OFF}$ $PV > (SV + GAP2 + HYS2) \rightarrow \text{OUT2 ON}$
diagram		

Example(4)
dual output(OUT1 : cool mode, OUT2 : heat mode)

Formula	Cool side	$PV \leq (SV + GAP1) \rightarrow \text{OUT1 OFF}$ $PV > (SV + GAP1 + HYS1) \rightarrow \text{OUT1 ON}$
	heat side	$PV \geq (SV + GAP2) \rightarrow \text{OUT2 OFF}$ $PV < (SV + GAP2 - HYS2) \rightarrow \text{OUT2 ON}$
diagram		

Notes

1. There is a large control error in ON/OFF control compared with PID control
2. Do not set the hysteresis parameter HYS1/HYS2 too small, so as to avoid frequent action of the relay and affect the lifetime
3. When performing ON/OFF control in dual output mode, both sets of outputs must be used for ON/OFF control, please do not adjust to one set of PID control and one set of ON/OFF control

10.13 Super SV

Description

When the SV is changed, the output increases, massive output may cause overshoot and damage the system. FY series controllers provide the Super SV function, which can effectively suppress the overshoot

The related parameters of Super SV are as below:

Parameter	Symbol	Content	Range		Default	Level	Hide/Display
			MAX	MIN			
OPAD		Super SV function, suppressing overshoot 0 : OFF 1 : ON	ON	OFF	OFF	Level 3	SET7.3

Example

Set the SV to 100.0°C, use the default PID value to control the industrial oven, and compare the control curves of Super SV function on or off

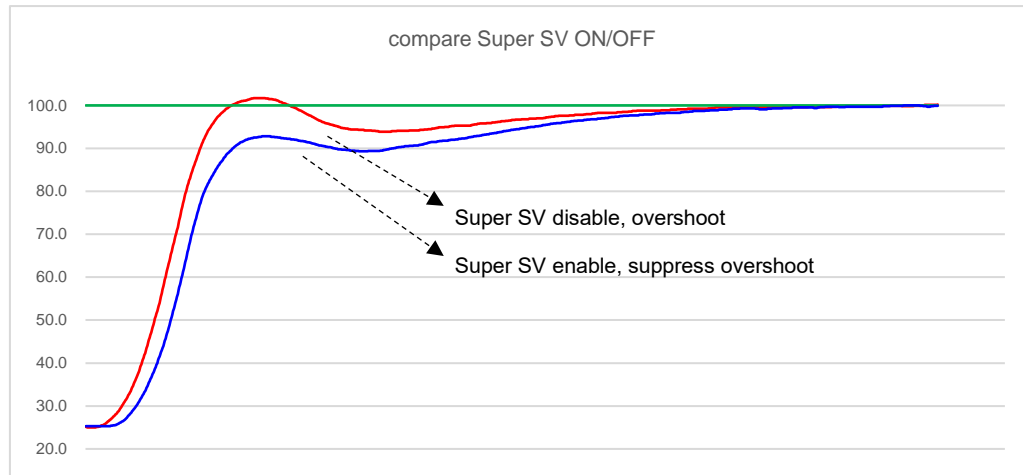

Notes



1. The time to reach the set value after enabling Super SV function may be longer than the time without Super SV function
2. I (Integral) value cannot be zero when using Super SV function
3. Super SV function is recommended for single output heating system

10.14 Input Math Function

Description

TFY series controllers provide advance mathematical function in terms of input linear signals, such as inverse, square root, square etc. Users can directly connect differential pressure type flow transmitter to controller, or other transmitters that require special conversion.

The related parameters of Input math function are as below:

Parameter	Symbol	Content	Range		Default	Level	Hide/Display
			MAX	MIN			
LSPL		Input scale low	9999	-1999	---	Level 3	SET2.3
USPL		Input scale high	9999	-1999	---	Level 3	SET2.3
MV.SF		Analog input special function selection 0 : NONE (special function OFF) 1 : SQUA (analog input square) 2 : ROOT (analog input square root) 3 : REVE (analog input reverse) 4 : SQ.RE (analog input square reverse) 5 : RO.RE (analog input square root reverse)	RO.RE	NONE	NONE	Fast Level	INP1=AN1~AN4

Notes

1. The parameter MV.SF is only available in when the input signal is a linear signal (INP1=AN1~AN4)
2. When using the SQUA/ROOT/SQ.RE/RO.RE function, you must ensure that the range is a positive range

Example(1)

Input signal 4~20mA aim range 0~1000, the value and graphical representation of MV.SF functions

input signal 4~20mA	NONE	REVE (reverse)	SQUA (square)	SQ.RE (square+ reverse)	ROOT (square root)	RO.RE (square root+ reverse)
4.00	0	1000	0.0	1000.0	0.00	1000.00
4.32	20	980	0.4	999.6	141.42	858.58
4.64	40	960	1.6	998.4	200.00	800.00
4.96	60	940	3.6	996.4	244.95	755.05
5.28	80	920	6.4	993.6	282.84	717.16
5.60	100	900	10.0	990.0	316.23	683.77
5.92	120	880	14.4	985.6	346.41	653.59
6.24	140	860	19.6	980.4	374.17	625.83
6.56	160	840	25.6	974.4	400.00	600.00
6.88	180	820	32.4	967.6	424.26	575.74
7.20	200	800	40.0	960.0	447.21	552.79
7.52	220	780	48.4	951.6	469.04	530.96
7.84	240	760	57.6	942.4	489.90	510.10
8.16	260	740	67.6	932.4	509.90	490.10
8.48	280	720	78.4	921.6	529.15	470.85
8.80	300	700	90.0	910.0	547.72	452.28
9.12	320	680	102.4	897.6	565.69	434.31
9.44	340	660	115.6	884.4	583.10	416.90
9.76	360	640	129.6	870.4	600.00	400.00
10.08	380	620	144.4	855.6	616.44	383.56
10.40	400	600	160.0	840.0	632.46	367.54
10.72	420	580	176.4	823.6	648.07	351.93
11.04	440	560	193.6	806.4	663.32	336.68
11.36	460	540	211.6	788.4	678.23	321.77
11.68	480	520	230.4	769.6	692.82	307.18
12.00	500	500	250.0	750.0	707.11	292.89
12.32	520	480	270.4	729.6	721.11	278.89
12.64	540	460	291.6	708.4	734.85	265.15
12.96	560	440	313.6	686.4	748.33	251.67
13.28	580	420	336.4	663.6	761.58	238.42
13.60	600	400	360.0	640.0	774.60	225.40
13.92	620	380	384.4	615.6	787.40	212.60
14.24	640	360	409.6	590.4	800.00	200.00
14.56	660	340	435.6	564.4	812.40	187.60
14.88	680	320	462.4	537.6	824.62	175.38
15.20	700	300	490.0	510.0	836.66	163.34
15.52	720	280	518.4	481.6	848.53	151.47
15.84	740	260	547.6	452.4	860.23	139.77
16.16	760	240	577.6	422.4	871.78	128.22
16.48	780	220	608.4	391.6	883.18	116.82
16.80	800	200	640.0	360.0	894.43	105.57
17.12	820	180	672.4	327.6	905.54	94.46
17.44	840	160	705.6	294.4	916.52	83.48
17.76	860	140	739.6	260.4	927.36	72.64
18.08	880	120	774.4	225.6	938.08	61.92
18.40	900	100	810.0	190.0	948.68	51.32
18.72	920	80	846.4	153.6	959.17	40.83
19.04	940	60	883.6	116.4	969.54	30.46
19.36	960	40	921.6	78.4	979.80	20.20
19.68	980	20	960.4	39.6	989.95	10.05
20.00	1000	0	1000.0	0.0	1000.00	0.00

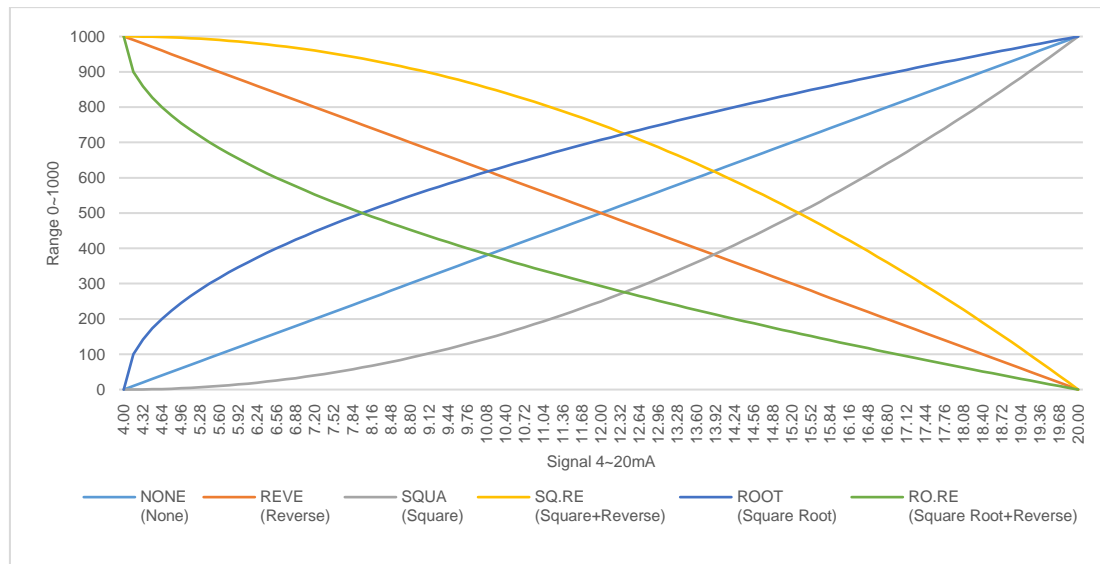

Example(2)

Input signal 0~10V aim range 0~1000, the value and graphical representation of MV.SF functions

input signal 0~10V	NONE	REVE (reverse)	SQUA (square)	SQ.RE (square+ reverse)	ROOT (square root)	RO.RE (square root+ reverse)
0.0	0	1000	0.0	1000.0	0.00	1000.00
0.2	20	980	0.4	999.6	141.42	858.58
0.4	40	960	1.6	998.4	200.00	800.00
0.6	60	940	3.6	996.4	244.95	755.05
0.8	80	920	6.4	993.6	282.84	717.16
1.0	100	900	10.0	990.0	316.23	683.77
1.2	120	880	14.4	985.6	346.41	653.59
1.4	140	860	19.6	980.4	374.17	625.83
1.6	160	840	25.6	974.4	400.00	600.00
1.8	180	820	32.4	967.6	424.26	575.74
2.0	200	800	40.0	960.0	447.21	552.79
2.2	220	780	48.4	951.6	469.04	530.96
2.4	240	760	57.6	942.4	489.90	510.10
2.6	260	740	67.6	932.4	509.90	490.10
2.8	280	720	78.4	921.6	529.15	470.85
3.0	300	700	90.0	910.0	547.72	452.28
3.2	320	680	102.4	897.6	565.69	434.31
3.4	340	660	115.6	884.4	583.10	416.90
3.6	360	640	129.6	870.4	600.00	400.00
3.8	380	620	144.4	855.6	616.44	383.56
4.0	400	600	160.0	840.0	632.46	367.54
4.2	420	580	176.4	823.6	648.07	351.93
4.4	440	560	193.6	806.4	663.32	336.68
4.6	460	540	211.6	788.4	678.23	321.77
4.8	480	520	230.4	769.6	692.82	307.18
5.0	500	500	250.0	750.0	707.11	292.89
5.2	520	480	270.4	729.6	721.11	278.89
5.4	540	460	291.6	708.4	734.85	265.15
5.6	560	440	313.6	686.4	748.33	251.67
5.8	580	420	336.4	663.6	761.58	238.42
6.0	600	400	360.0	640.0	774.60	225.40
6.2	620	380	384.4	615.6	787.40	212.60
6.4	640	360	409.6	590.4	800.00	200.00
6.6	660	340	435.6	564.4	812.40	187.60
6.8	680	320	462.4	537.6	824.62	175.38
7.0	700	300	490.0	510.0	836.66	163.34
7.2	720	280	518.4	481.6	848.53	151.47
7.4	740	260	547.6	452.4	860.23	139.77
7.6	760	240	577.6	422.4	871.78	128.22
7.8	780	220	608.4	391.6	883.18	116.82
8.0	800	200	640.0	360.0	894.43	105.57
8.2	820	180	672.4	327.6	905.54	94.46
8.4	840	160	705.6	294.4	916.52	83.48
8.6	860	140	739.6	260.4	927.36	72.64
8.8	880	120	774.4	225.6	938.08	61.92
9.0	900	100	810.0	190.0	948.68	51.32
9.2	920	80	846.4	153.6	959.17	40.83
9.4	940	60	883.6	116.4	969.54	30.46
9.6	960	40	921.6	78.4	979.80	20.20
9.8	980	20	960.4	39.6	989.95	10.05
10.0	1000	0	1000.0	0.0	1000.00	0.00

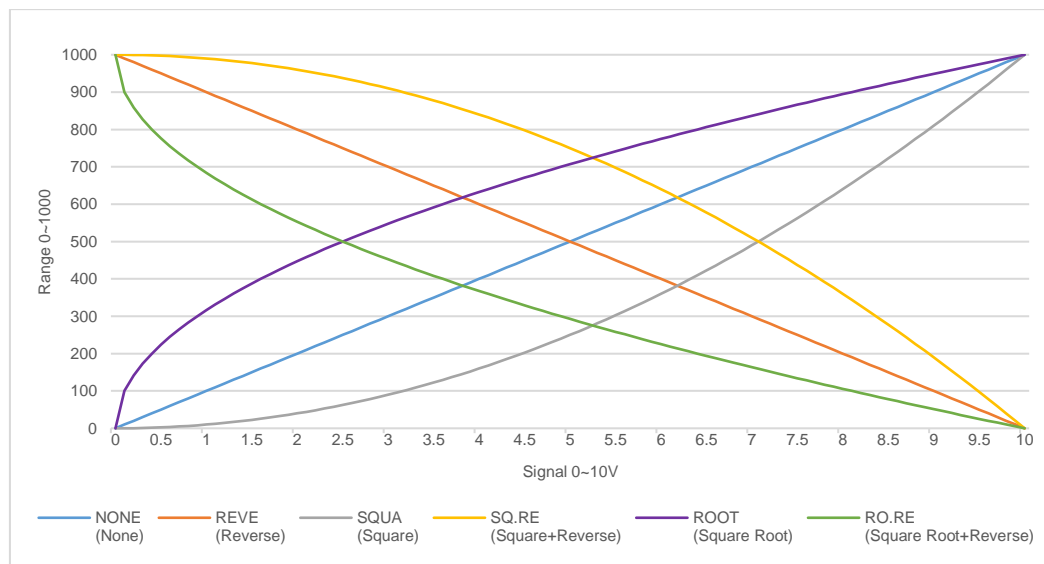

11. Alarm Action

Description

The FY/FA series controller can support up to three sets of alarm functions. Each set of alarms has 19 mode. Users can choose the most suitable alarm mode according to their needs for system protection or application.

Function Diagram

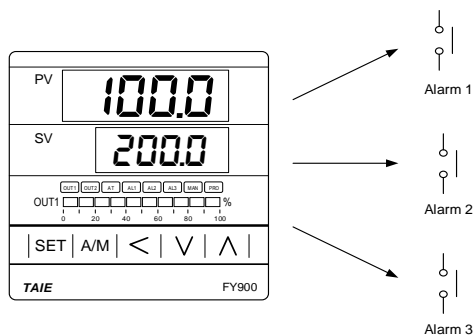

The related parameters of alarm function are as below:

Parameter	Symbol	Content	Range		Default	Level	Hide/Display
			MAX	MIN			
AL1	<i>AL1</i>	Alarm1 set value	USPL	-1999	1.0	Level 1	SET1.3
AL2	<i>AL2</i>	Alarm2 set value	USPL	-1999	1.0	Level 1	SET1.4
AL3	<i>AL3</i>	Alarm3 set value	USPL	-1999	1.0	Level 1	SET2.1
ALD1	<i>ALD1</i>	Alarm1 mode selection (Please refer to Chapter 11.1 Alarm Mode)	19	0	11	Level 3	SET3.1
ALT1	<i>ALT1</i>	Alarm1 time setting 0 : Flicker 99.59 : Continued ON 0.01~99.58 : delay time Time format : min . sec	99.59	0.00	99.59	Level 3	SET3.2
ALD2	<i>ALD2</i>	Alarm2 mode selection (Please refer to Chapter 11.1 Alarm Mode)	19	0	11	Level 3	SET3.3
ALT2	<i>ALT2</i>	Alarm2 time setting 0 : Flicker 99.59 : Continued ON 0.01~99.58 : delay time Time format : min . sec	99.59	0.00	99.59	Level 3	SET3.4
ALD3	<i>ALD3</i>	Alarm3 mode selection (Please refer to Chapter 11.1 Alarm Mode)	18	0	11	Level 3	SET4.1
ALT3	<i>ALT3</i>	Alarm3 time setting 0 : Flicker 99.59 : Continued ON 0.01~99.58 : delay time Time format : min . sec	99.59	0.00	99.59	Level 3	SET4.2
HYSA	<i>HYSA</i>	Hysteresis setting for alarm1~3	999.9	-199.9	1.0	Level 3	SET4.3
SETA	<i>SETA</i>	Alarm special function setting (Please refer to Chapter 11.2)	1111	0000	0000	Level 3	SET5.3

11.1 Alarm Mode

▲ : SV △ : Alarm set value X : 1 / 2 / 3 (There are up to 3 sets of alarms)

ALDX	Alarm mode	Description
0	No alarm function	Not drive any alarm relays and the corresponding LED lamp.
1	Deviation high (With hold action)	
		Formula $PV \geq (SV+ALX) \rightarrow \text{Alarm ON}$ $PV \leq (SV+ALX-HYSA) \rightarrow \text{Alarm OFF}$
2	Deviation low (With hold action)	<p>*ALX must be set to a negative value</p>
		Formula $PV \leq (SV+ALX) \rightarrow \text{Alarm ON}$ $PV \geq (SV+ALX+HYSA) \rightarrow \text{Alarm OFF}$
3	Deviation high/low (With hold action)	
		Formula $PV \geq (SV+ALX) \rightarrow \text{Alarm ON}$ $PV \leq (SV-ALX) \rightarrow \text{Alarm ON}$ $PV \geq (SV-ALX+HYSA) \rightarrow \text{Alarm OFF}$ $PV \leq (SV+ALX-HYSA) \rightarrow \text{Alarm OFF}$
4	Band (With hold action)	
		Formula $PV \leq (SV+ALX) \rightarrow \text{Alarm ON}$ $PV \geq (SV-ALX) \rightarrow \text{Alarm ON}$ $PV > (SV+ALX) \rightarrow \text{Alarm OFF}$ $PV < (SV-ALX) \rightarrow \text{Alarm OFF}$
5	Process high (With hold action)	
		Formula $PV \geq ALX \rightarrow \text{Alarm ON}$ $PV \leq (ALX-HYSA) \rightarrow \text{Alarm OFF}$
6	Process low (With hold action)	
		Formula $PV \leq ALX \rightarrow \text{Alarm ON}$ $PV \geq (ALX+HYSA) \rightarrow \text{Alarm OFF}$
7	Segment execute alarm	When SEG=ALX alarm ON *This mode only available in program type controller
8	System error	The Alert action, when PV displays error message
9	HBA (Heater Break Alarm)	Activated conditions : 1. Heater current is less the HBAC set value 2. OUT1 manipulated value exceed HBOP set value 3. Conditions of 1 & 2 above are established and continue to exceed 20 seconds. *Please refer to Chapter 10.4 *This mode only available in ALD1 or ALD2
	Single RAMP	Please refer to Chapter 10.7 This mode only available in ALD3

11.1 Alarm Mode

▲ : SV △ : Alarm set value X : 1 / 2 / 3 (There are up to 3 sets of alarms)

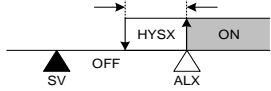
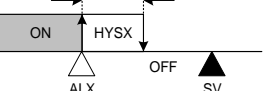
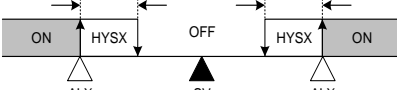
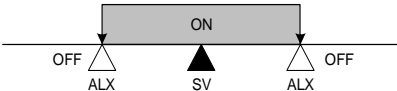
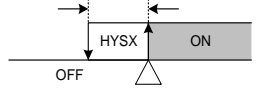
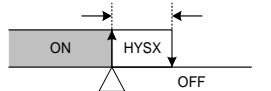
ALDX	Alarm mode	Description
10	SOAK_A	<p>Boot completed, the alarm is ON, when $PV \geq$ target SV start the timer, alarm and control function are turned OFF in timed out.</p> <p>If the RAMP function is used, even if the RAMP SV has not reached the target SV, the timer will start counting as long as the condition $PV \geq$ target SV is met.</p> <p>*Please refer to Chapter 10.7</p> <p>*This mode only available in ALD1 or ALD2</p> <p>*In this mode, the time format is fixed to "hour.minute"</p>
11	Deviation high	 <p>Formula</p> $PV \geq (SV+ALX) \rightarrow \text{Alarm ON}$ $PV \leq (SV+ALX-HYSA) \rightarrow \text{Alarm OFF}$
12	Deviation low	 <p>*ALX must be set to a negative value</p> <p>Formula</p> $PV \leq (SV+ALX) \rightarrow \text{Alarm ON}$ $PV \geq (SV+ALX+HYSA) \rightarrow \text{Alarm OFF}$
13	Deviation high/low	 <p>Formula</p> $PV \geq (SV+ALX) \rightarrow \text{Alarm ON}$ $PV \leq (SV-ALX) \rightarrow \text{Alarm ON}$ $PV \geq (SV-ALX+HYSA) \rightarrow \text{Alarm OFF}$ $PV \leq (SV+ALX-HYSA) \rightarrow \text{Alarm OFF}$
14	Band	 <p>Formula</p> $PV \leq (SV+ALX) \rightarrow \text{Alarm ON}$ $PV \geq (SV-ALX) \rightarrow \text{Alarm ON}$ $PV > (SV+ALX) \rightarrow \text{Alarm OFF}$ $PV < (SV-ALX) \rightarrow \text{Alarm OFF}$
15	Process high	 <p>Formula</p> $PV \geq ALX \rightarrow \text{Alarm ON}$ $PV \leq (ALXH-HYSA) \rightarrow \text{Alarm OFF}$
16	Process low	 <p>Formula</p> $PV \leq ALX \rightarrow \text{Alarm ON}$ $PV \geq (ALX+HYSA) \rightarrow \text{Alarm OFF}$
17	Program run	<p>SETA.4=0 When program execution, alarm action</p> <p>SETA.4=1 When program end, alarm action</p> <p>*This mode only available in program type controller</p>
18	System normal	The Alert action, when system in normal condition (no-error message)

11.1 Alarm Mode

ALDX	Alarm mode	Description
19	SOAK_B	<p>Boot completed, the alarm is OFF, when PV \geq target SV start the timer, alarm is turned ON and the control function keep ON in timed out.</p> <p>If the RAMP function is used, even if the RAMP SV has not reached the target SV, the timer will start counting as long as the condition PV \geq target SV is met.</p> <p>*Please refer to Chapter 10.7</p> <p>*This mode only available in ALD1 or ALD2</p> <p>*In this mode, the time format is fixed to "hour.minute"</p>

11.2 Alarm Special Setting

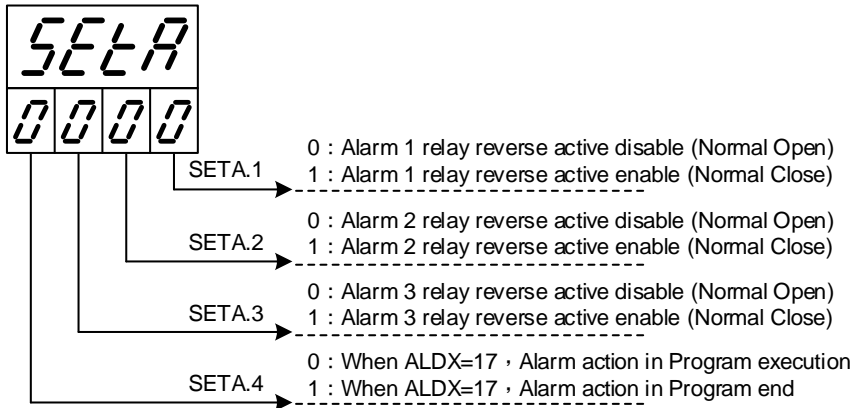

11.3 Alarm Example

Example 1 : Deviation low, the difference between With alarm hold action and without alarm hold action, shown in the diagram below

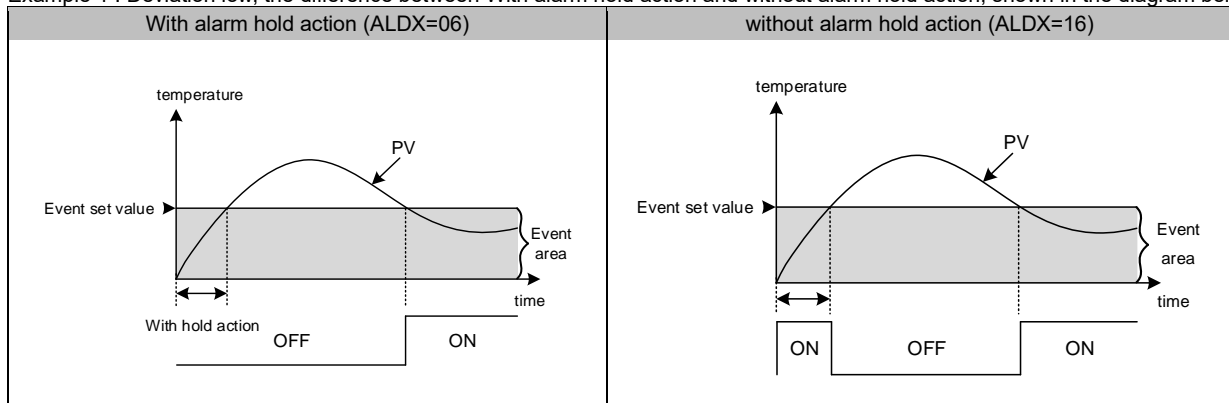

12. Programmable

Description

Programmable function is SV function that is variable to time, as user can set SV value to their needs according to time-based variation curve, which is called program setting

1. There are at most 18 sets of pattern setting
2. Every set of pattern can at most have 8 segments
3. Every segment include 4 settings such as ramp, soak, step and continue
4. Pattern can be randomly linked up, as each pattern of program contains 144 segment, at most.

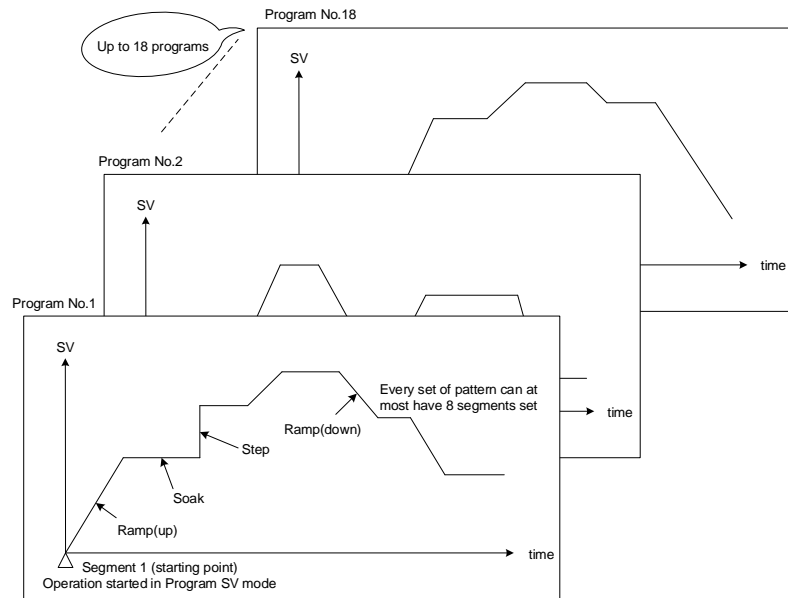

12.1 Parameter

Parameter	Symbol	Content	Range		Default	Level	Hide/Display
			MAX	MIN			
PTN		Program pattern selection 1~18	18	1	1	Level 1	PROG=ON
SEG		Current program segment display	144	1	1	Level 1	PROG=ON
TIMR		Current segment remain time display Upper area : display current segment remain time Down area : display current segment executed time	99.59	0.00	0.00	Level 1	PROG=ON
SV_1		Segment 1 SV	USPL	LSPL	0.0	Level 1	PROG=ON
TM_1		Segment 1 execute time setting, this parameter determines the link between segment and segment or pattern and pattern END(-1) : program end in this segment 0.00 : program step change in this segment 0.01~99.58 : program in this segment execute time 99.59 : program continue execute this segment, no end	99.59	-1	0.00	Level 1	PROG=ON
OUT1		Segment 1 output limit	100.0	0.0	100.0	Level 1	PROG=ON
SV_2		Segment 2 SV	USPL	LSPL	0.0	Level 1	PROG=ON
TM_2		Segment 2 execute time setting	99.59	-1	0.00	Level 1	PROG=ON
OUT2		Segment 2 output limit	100.0	0.0	100.0	Level 1	PROG=ON
SV_3		Segment 3 SV	USPL	LSPL	0.0	Level 1	PROG=ON
TM_3		Segment 3 execute time setting	99.59	-1	0.00	Level 1	PROG=ON
OUT3		Segment 3 output limit	100.0	0.0	100.0	Level 1	PROG=ON

12.1 Parameter

Parameter	Symbol	Content	Range		Default	Level	Hide/Display
			MAX	MIN			
SV_4		Segment 4 SV	USPL	LSPL	0.0	Level 1	PROG=ON
TM_4		Segment 4 execute time setting	99.59	-1	0.00	Level 1	PROG=ON
OUT4		Segment 4 output limit	100.0	0.0	100.0	Level 1	PROG=ON
SV_5		Segment 5 SV	USPL	LSPL	0.0	Level 1	PROG=ON
TM_5		Segment 5 execute time setting	99.59	-1	0.00	Level 1	PROG=ON
OUT5		Segment 5 output limit	100.0	0.0	100.0	Level 1	PROG=ON
SV_6		Segment 6 SV	USPL	LSPL	0.0	Level 1	PROG=ON
TM_6		Segment 6 execute time setting	99.59	-1	0.00	Level 1	PROG=ON
OUT6		Segment 6 output limit	100.0	0.0	100.0	Level 1	PROG=ON
SV_7		Segment 7 SV	USPL	LSPL	0.0	Level 1	PROG=ON
TM_7		Segment 7 execute time setting	99.59	-1	0.00	Level 1	PROG=ON
OUT7		Segment 7 output limit	100.0	0.0	100.0	Level 1	PROG=ON
SV_8		Segment 8 SV	USPL	LSPL	0.0	Level 1	PROG=ON
TM_8		Segment 8 execute time setting	99.59	-1	0.00	Level 1	PROG=ON
OUT8		Segment 8 output limit	100.0	0.0	100.0	Level 1	PROG=ON
WAIT		Program execution standby temperature 0 : when program execute do not wait for PV temperature Other values : when PV= (target SV-WAIT), program entering next segment	1000	0	0	Level 1	SET5.3
SET8.1		Program execute repeat 0 : disable repeat function 1 : Program execute repeat	1	0	0	Level 4	---
SET8.2		Program execute power fail protection 0 : disable power fail protection 1 : enable power fail protection	1	0	0	Level 4	---
SET8.3		Program execute start address 0 : execute from zero 1 : execute from current PV	1	0	1	Level 4	---
SET9.2		Program time format 0 : hour.minute 1 : minute.second	1	0	0	Level 4	---
PVST		Program execute start address 0 : FULT (execute from current PV, but use segment 1 fully time) 1 : CUTT (execute from current PV, cut time)	CUTT	FULT	FULT	Fast	SET8.3

12.2 Key Operation Description

Functions	Keys	Description
Run		Eexecuting program, PRO_LED lamp ON, Upper area shows 3 times "RUN" messages.
Halt		Pause executing program, PRO_LED lamp remains ON, at this moment upper area will display current temperature value and "HALT" message alternately.
Jump	+	Jump to the next segment, and it can skip segment continuously.
		Holding UP key and press SET key 1 time to skip 1 segment, press SET key 2 times to skip 2 segments, so on and so forth.
Reset	+	Stop executing program, PRO_LED lamp OFF, Upper area shows 3 times "REST" messages.
PV/SV monitor		Press the A / M key for 2 seconds jump to the parameter OUTL, then pressing the A / M key for 2 seconds return to PV / SV monitor.

12.3 Program Initial Setting

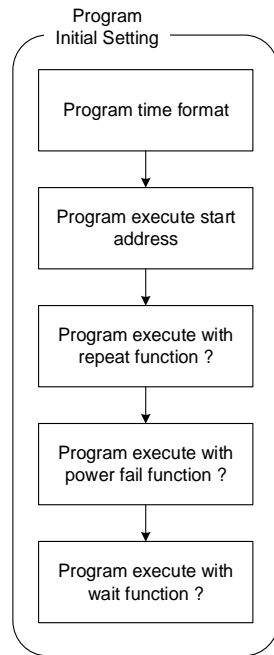

1. Setting program time format

Parameter	LED display	Description	Default	Level
SET9.2	<i>SEt9</i>	Program time format 0 : hour.minute 1 : minute.second	0	Level 4

This parameter determines the time format of timer during program execution

When SET9.2 = 0 , TM_n=33.23, it indicates that the execution time of this segment is 33 hours and 23 minutes

When SET9.2 = 1 , TM_n=33.23, it indicates that the execution time of this segment is 33 minutes and 23 seconds

2. Setting program execute start address

Parameter	LED display	Description	Default	Level
SET8.3	<i>SEt8</i>	Program execute start address 0 : execute from zero 1 : execute from current PV	1	Level 4
PVST	<i>PVSt</i>	Program execute start address 0 : FULT (execute from current PV, but use segment 1 fully time) 1 : CUTT (execute from current PV, cut time)	FULT	Fast

When program starts, SV initial value will execute according to SET8.3 and PVST setting value

(1) SET8.3 = 0, PTN=1, PV=50.0, SV_1=100.0, TM_1=1.00(1 hour)

When program starts, SV will start to execute from PV, and SV shall reach SV_1 in one hour

(2) SET8.3 = 1, PVST=FULT, PTN=1, PV=50.0, SV_1=100.0, TM_1=1.00(1 hour)

When program starts, SV will start to execute from PV temperature of 50.0, and SV shall reach SV_1 in one hour

(3) SET8.3 = 1, PVST=CUTT, PTN=1, PV=50.0, SV_1=100.0, TM_1=1.00(1 hour)

When program starts, SV will start to execute from PV, while controller will deduct the time taken to go from 0.0 to 50.0, as SV shall reach SV_1 in half hour

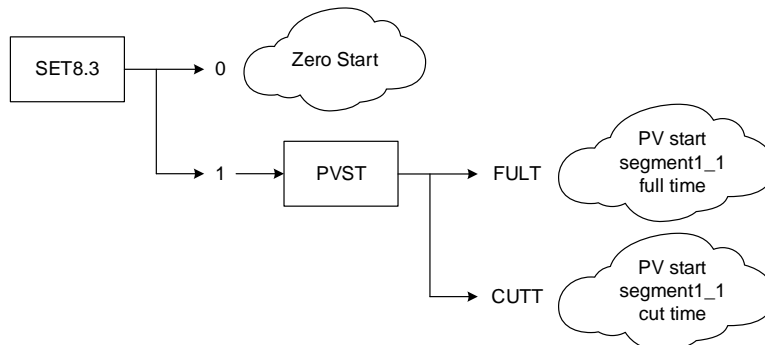

3. Setting program execute with repeat function

Parameter	LED display	Description	Default	Level
SET8.1		Program execute repeat 0 : disable repeat function 1 : Program execute repeat	0	Level 4

When program completes the execution of the final segment, and "END" message is not shown, the program will be executed again.

4. Setting program execute with power failure protection function

Parameter	LED display	Description	Default	Level
SET8.2		Program execute power fail protection 0 : disable power fail protection 1 : enable power fail protection	0	Level 4

power failure during program execution, if there is power failure protection function set, controller will execute current segment program after booting finish

Assume power failure occurring in the segment_4, ramp temperature from 100°C to 200°C, and power failure occurring at SV=125, the program will execute from 100°C (segment_4), after controller booting finish

5. Setting program execute with wait function

Parameter	LED display	Description	Default	Level
WAIT		Program execution standby temperature 0 : when program execute do not wait for PV temperature Other values : when PV=(target SV-WAIT), program entering next segment	0.0	Level 3

When program executes, if WAIT=0.0, and SV reaches set temperature, whether PV reaches target temperature or not, the controller will enter the next segment

When program executes, if WAIT value is not 0.0, and SV reaches set temperature, as PV has not reached target temperature, controller will wait for PV temperature to reach (target SV-WAIT)

(1) WAIT = 0.0 without wait function set

Assume the set temperature of current segment is 100.0°C, and as SV reaches the set temperature of this segment, the controller will enter the next segment

(2) WAIT = 5.0 with wait function set

Assume the set temperature of current segment is 100.0°C, and as SV reaches the set temperature of this segment, PV temperature needs to reach 100.0-5.0 (SV-WAIT)=95.0 then entering the next segment

12.4 Create Program

There are 18 sets PTN to choose and each PTN have 8 segments for setting

Program structure diagram

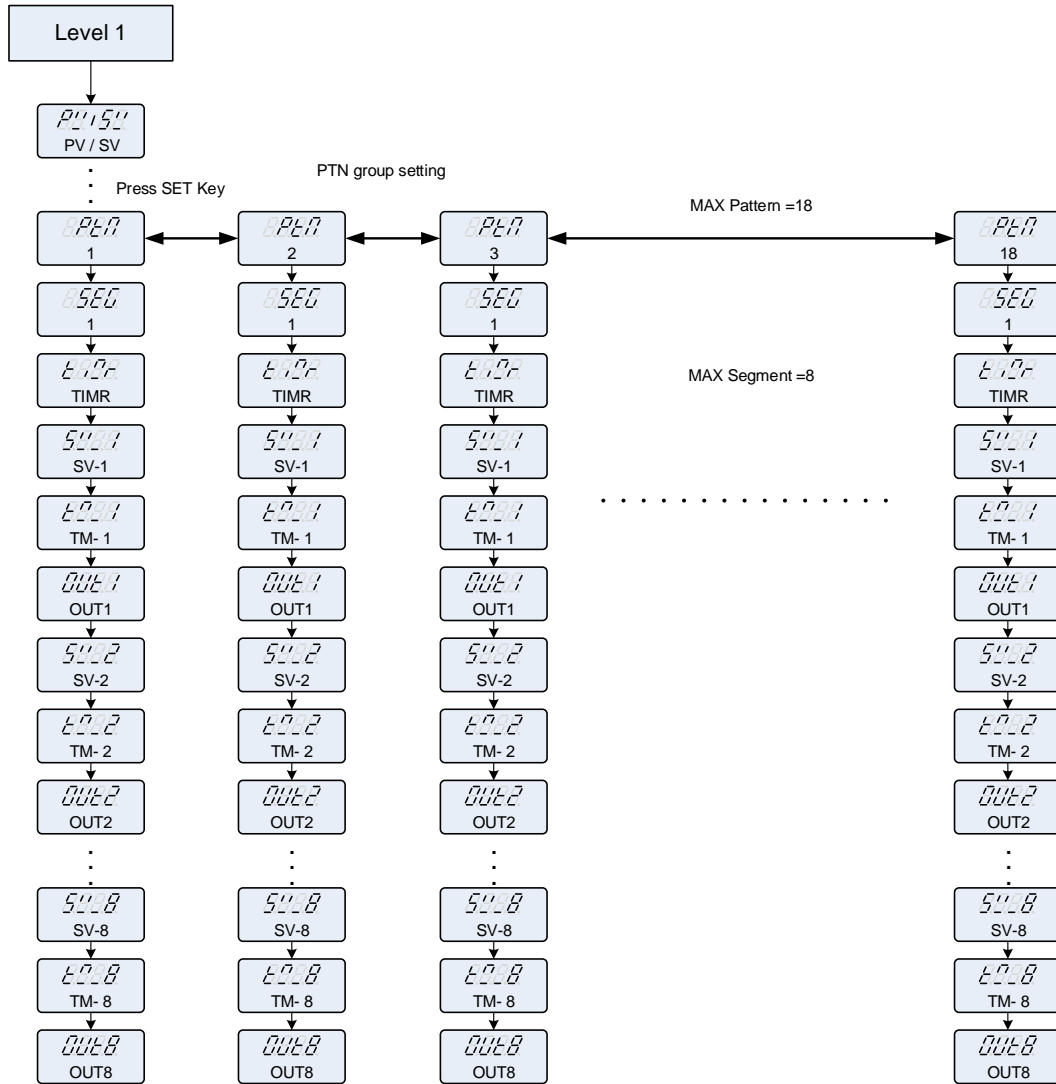

Program edit flow-chart

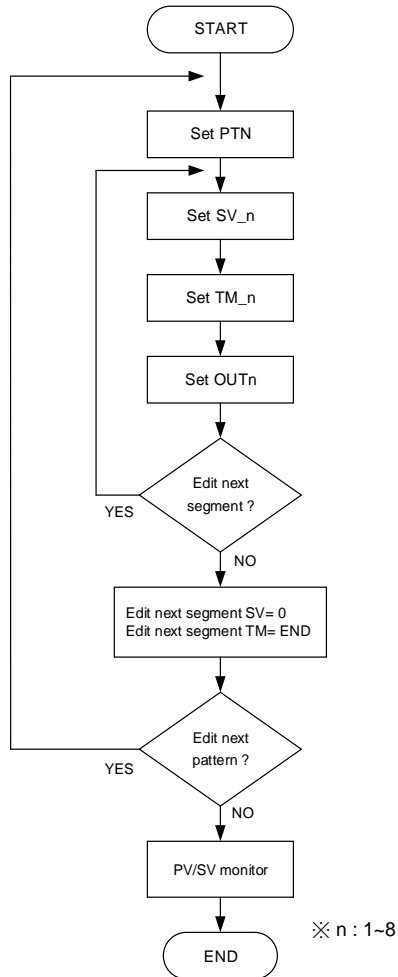

1. Choose program pattern number

Parameter	LED display	Description	Default	Level
PTN		Program pattern selection 1~18	1	Level 1

2. Setting segment n target SV

Parameter	LED display	Description	Default	Level
SV_n		Segment n SV (n=1~8)	0	Level 1

3. Setting segment n TM

Parameter	LED display	Description	Default	Level
TM_n		Segment 1 execute time setting, this parameter determines the link between segment and segment or pattern and pattern END(-1) : program end in this segment 0.00 : program step change in this segment 0.01~99.58 : program in this segment execute time 99.59 : program continue execute in this segment, no end	0	Level 1

TM setting explain :

In segment_5(SEG_5) setting TM_5 =END → When the program finishes segment_4(SEG_4), program end and display “END” Message in segment_5(SEG_5).

In segment_5(SEG_5) setting TM_5=0.00 → When the program finishes segment_4(SEG_4), enter next segment, SV change suddenly.

In segment_5(SEG_5) setting TM_5 =10.00 → When the program finishes segment_4(SEG_4), enter next segment and executing TM_5 setting value.

In segment_5(SEG_5) setting TM_5 =99.59 → When the program finishes segment_4(SEG_4) , enter next segment and executing continuously.

4. Setting segment n OUTn

Parameter	LED display	Description	Default	Level
OUTn		Segment n output limit (n=1~8)	100.0	Level 1

Notes

1. When the program is executed, it will end when it hits TIMR=END. Please be sure to add an end segment after the last segment of the program.
2. When OUD=COOL, no matter what the PVST setting is, it will always start with PVST=FULT
3. Programs can be started from different PTN to execute different recipes
4. user can use the " Program Design Table " of [chapter 19](#) to plan the recipe in advance

12.5 Program Execution Flow

The program can be up to 18 patterns. If you connect all the patterns, up to 144 segments.

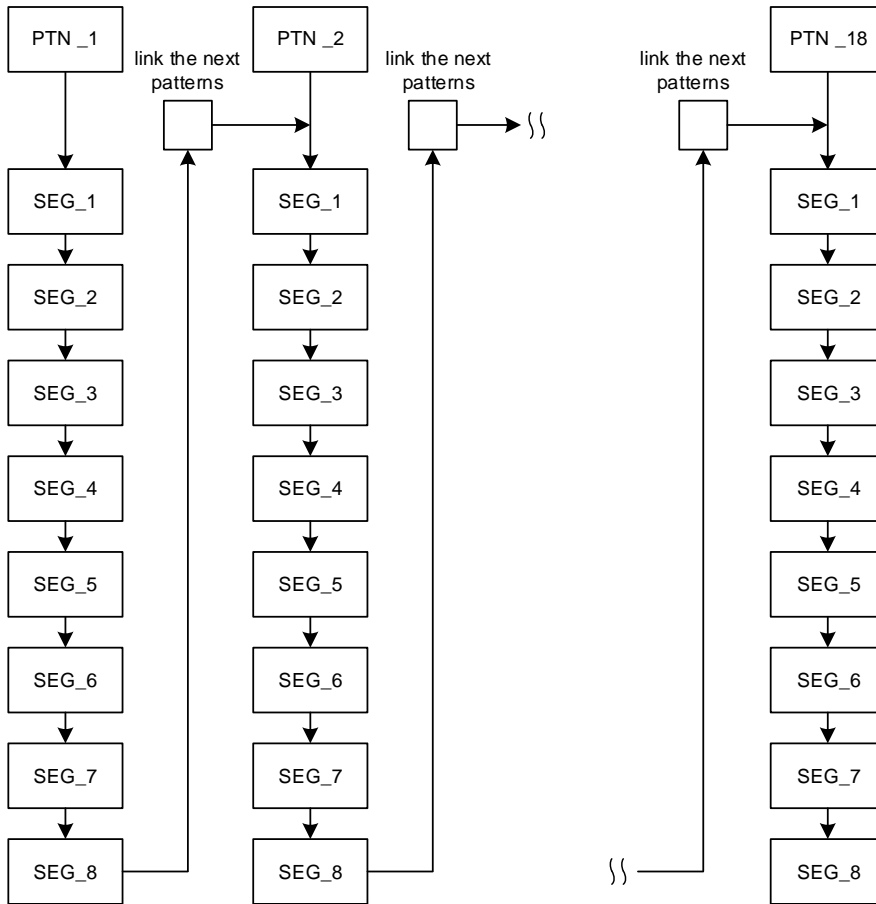

12.6 Program Setting Example

In pattern_1 edit program ramp, soak, step then end

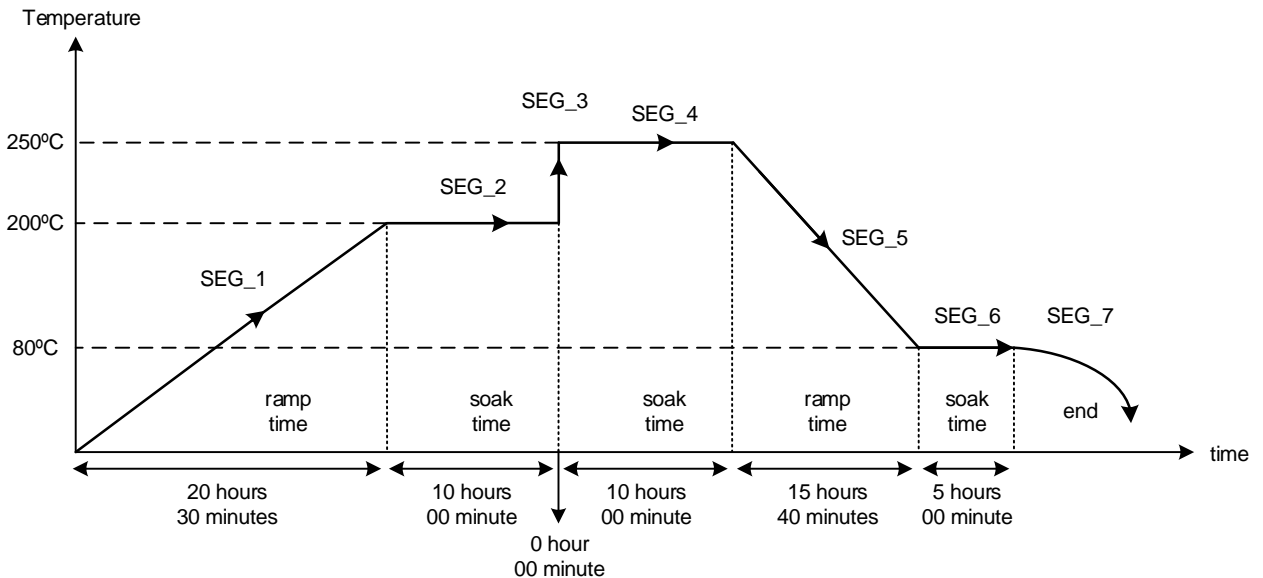

Initial setting

SET9.2 = 0	SET8.3 = 0	SET8.1 = 0	SET8.2 = 1	WAIT = 0.5
------------	------------	------------	------------	------------

Program edit

Segment_1	Segment_2	Segment_3	Segment_4	Segment_5	Segment_6	Segment_7
PTN = 1	PTN = 1	PTN = 1	PTN = 1	PTN = 1	PTN = 1	PTN = 1
SV_1 = 200	SV_2 = 200	SV_3 = 250	SV_4 = 250	SV_5 = 80	SV_6 = 80	SV_7 = 0
TM_1 = 20.30	TM_2 = 10.00	TM_3 = 0.00	TM_4 = 10.00	TM_5 = 15.40	TM_6 = 05.00	TM_7 = END
OUT1 = 100.0	OUT2 = 100.0	OUT3 = 100.0	OUT4 = 100.0	OUT5 = 100.0	OUT6 = 100.0	OUT7 = 0.0

13. Modification of Output Module

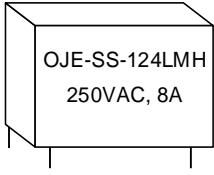
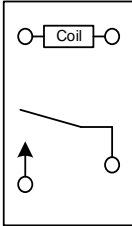

13.1 Relay Control (1a)

Side view	Bottom view	Software Setting
 <p>OJE-SS-124LMH 250VAC, 8A</p>		Parameter set as "CYT1 =10"

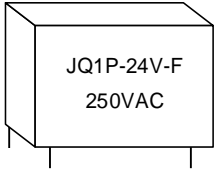
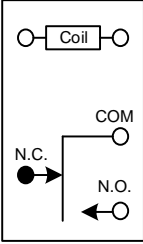
13.2 Relay Control (1c)

Side view	Bottom view	Software Setting
 <p>JQ1P-24V-F 250VAC</p>		Parameter set as "CYT1 =10"

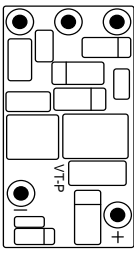
13.3 SSR Control

Top view	Bottom view	Software Setting
 <p>Volt module</p>		Parameter set as "CYT1 =1"

13.4 Linear Control

※ : When modifying mA current module, output signal needs to be calibrated, and for detailed calibration procedure, please refer to Chap. [13.5 Output Calibration Procedure Diagram](#).

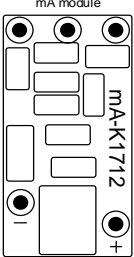
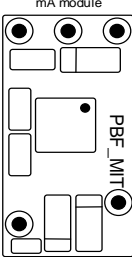
Top view	Bottom view	Software Setting
 <p>mA module</p>		Parameter set as "CYT1 =0"

13.5 Output Calibration Procedure Diagram

Output1 Signal (4mA~20mA) calibration flowchart

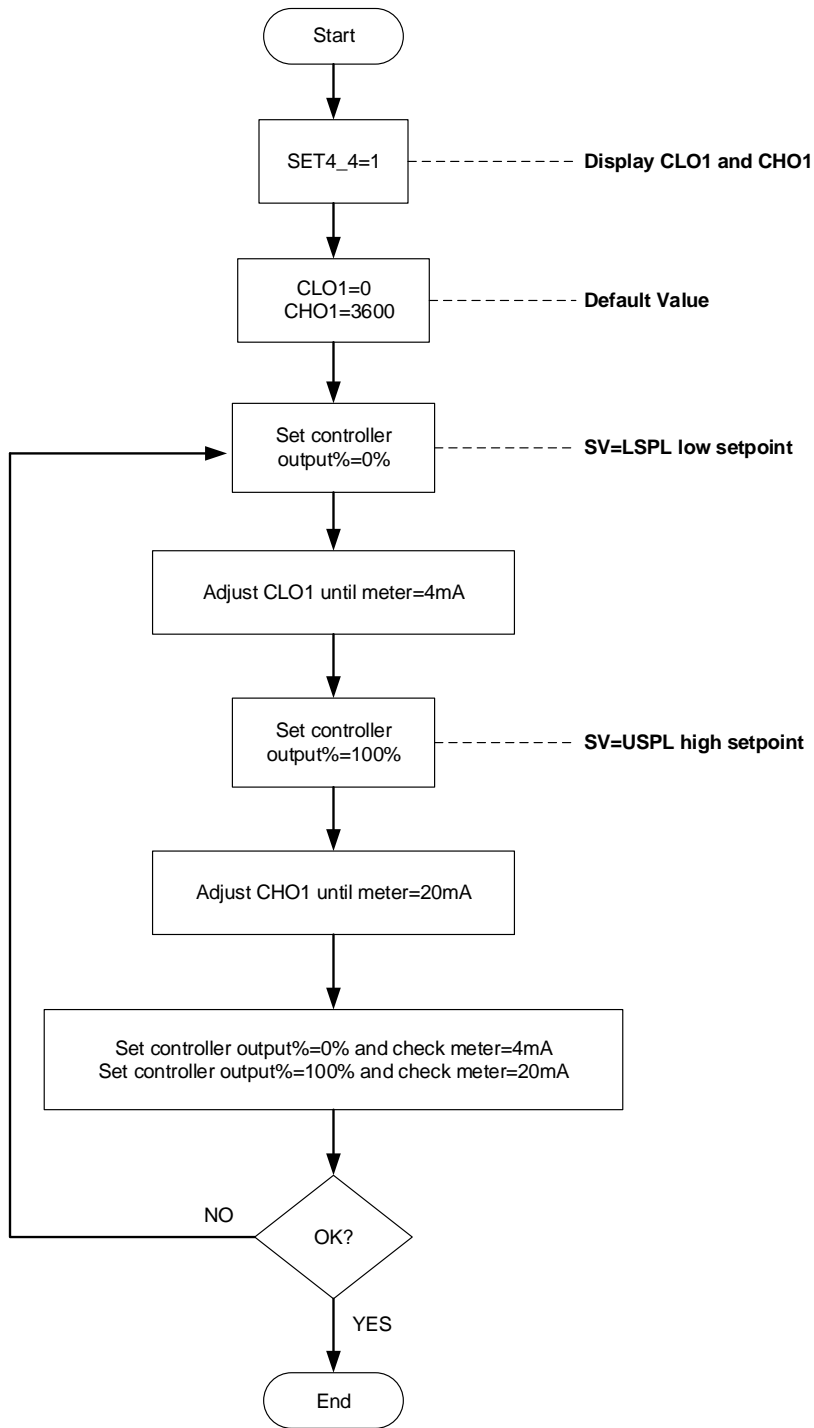

13.6 Output Calibration Steps

1. Display CLO1 & CHO1 :

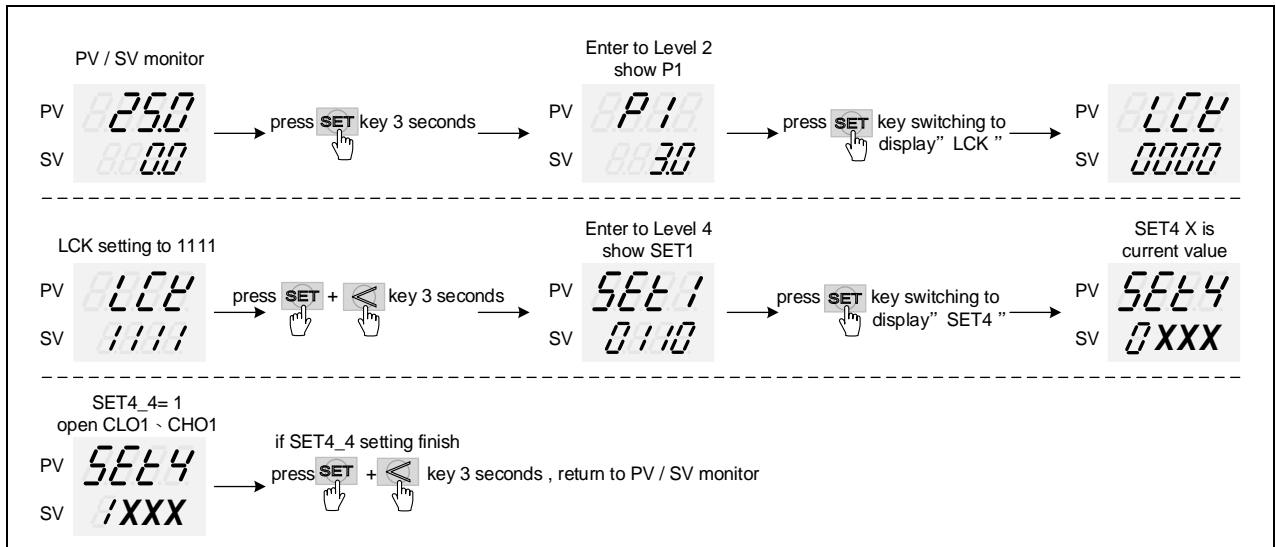

※ : X is default value which does not need to be modified

2. Adjust CLO1 low-point calibration value :

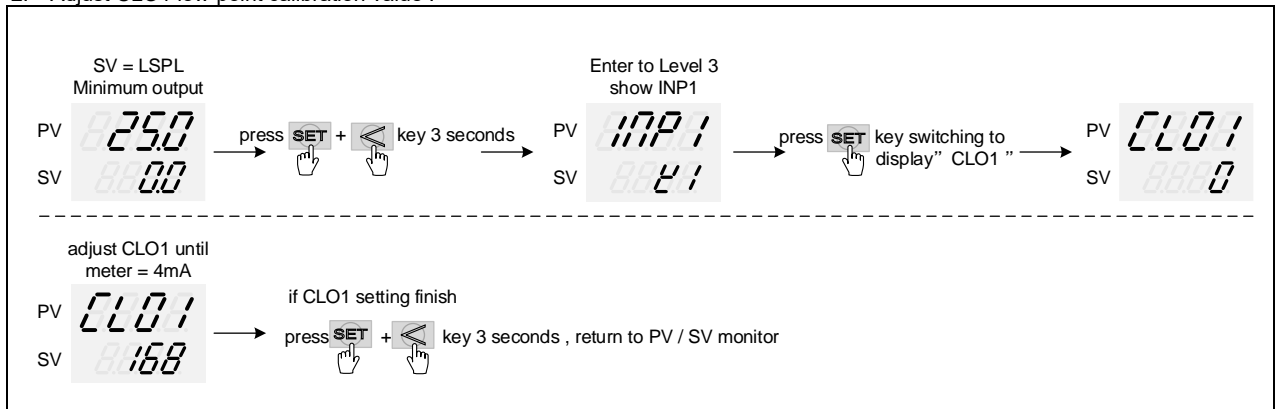

※ : CLO1 calibration value of each controller is different from the other

3. Adjust CHO1 high-point calibration value

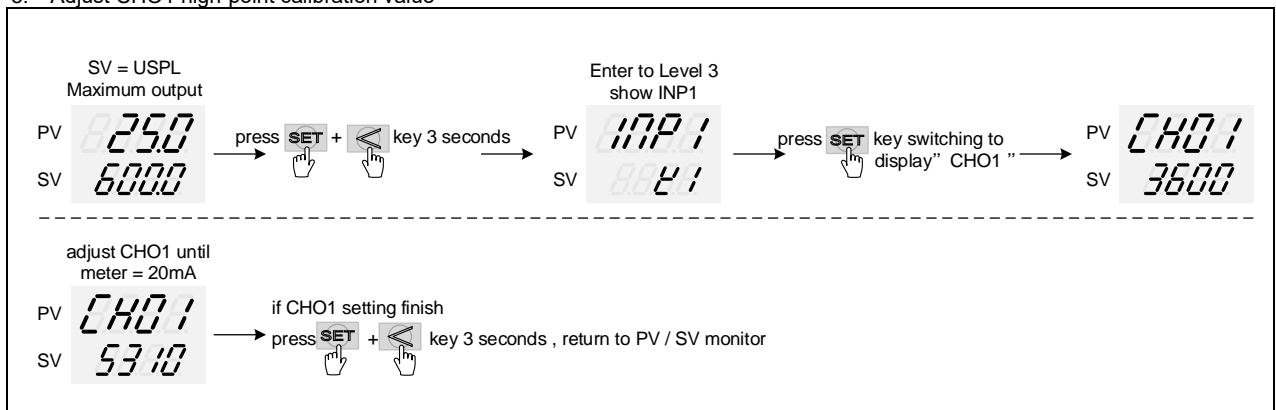

※ : CHO1 calibration value of each controller is different from the other

14. Modification of Input Signal

14.1 Input modify to thermocouple

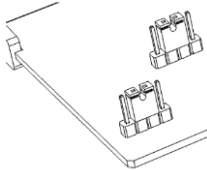
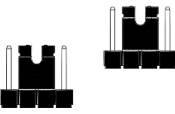
Jumper Position		Software Setting
Plug 2 pcs of Jumper in the middle slot as shown		
		Parameter set as "INP1=K1~L"

Thermocouple calibration flow chart

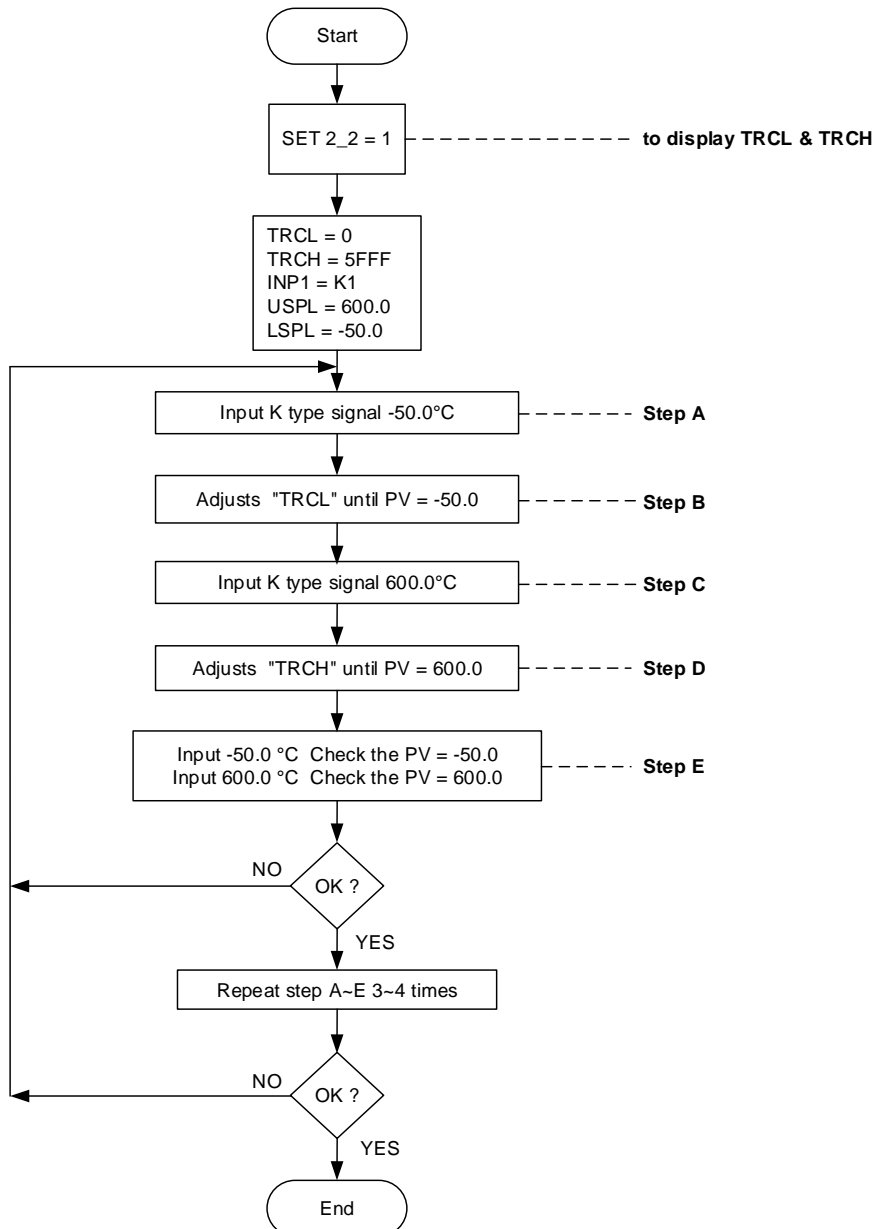

Set the range you want
 Ex: Low = 0.0 , High = 200.0
 Set LSPL = 0.0 , USPL = 200.0

Notes

When input is thermocouple or PT100, it has been calibrated and tested at the factory, we don't recommend customers to make their own calibration.

14.2 Input modify to RTD

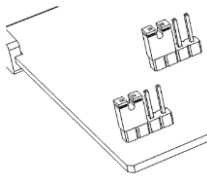
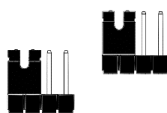
Jumper Position		Software Setting
Plug 2 pcs of Jumper in the left slot as shown		Parameter set as "INP1=PT1~PT3"
		

RTD calibration flow chart

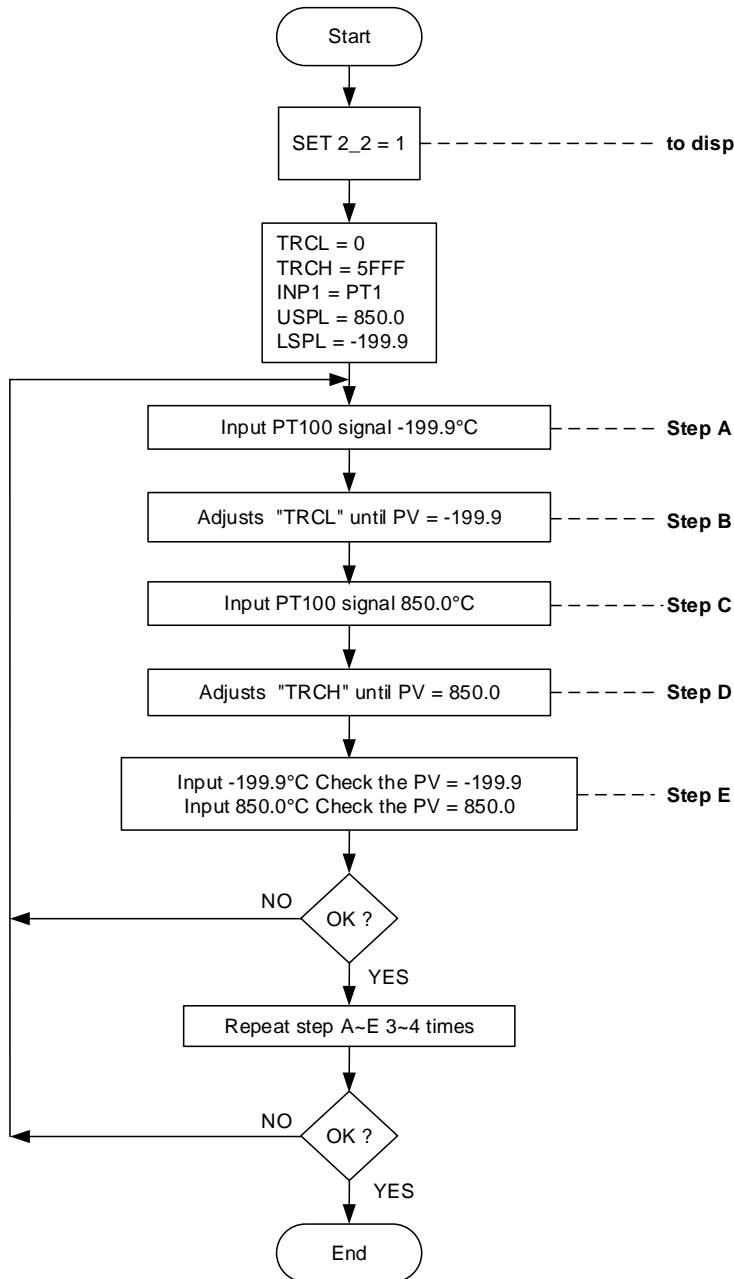

Set the range you want

Ex: Low = 0.0 , High = 200.0
Set LSPL = 0.0 , USPL = 200.0

Notes

When input is thermocouple or PT100, it has been calibrated and tested at the factory, we don't recommend customers to make their own calibration.

14.3 Input modify to Linear (4~20mA)

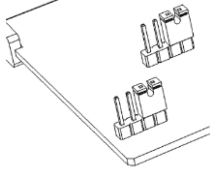
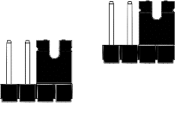
Jumper Position		Software Setting
Plug 2 pcs of Jumper in the right slot as shown		
		Parameter set as "INP1=AN4"

Linear analog signal (4~20mA) calibration flow chart

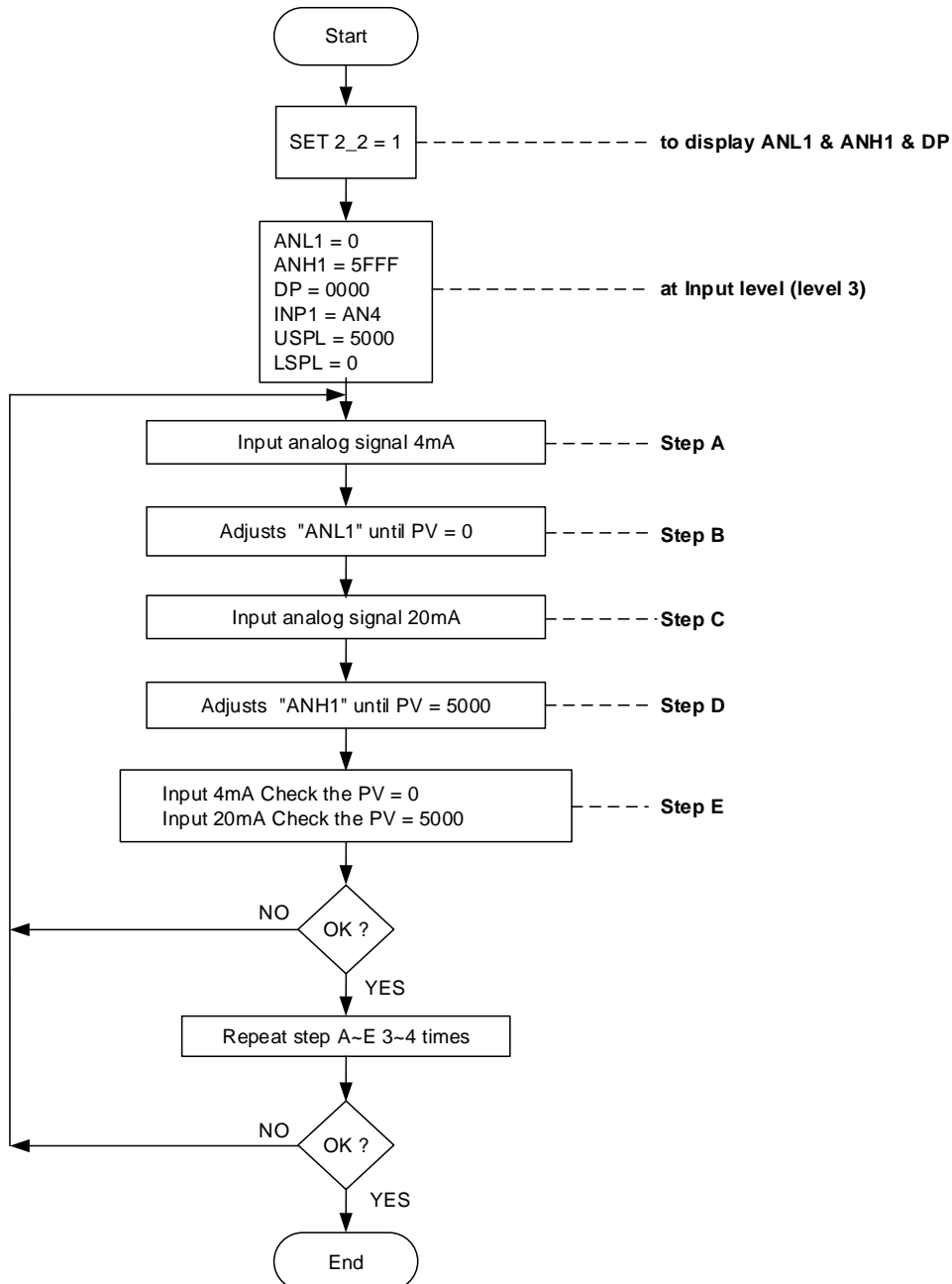

Set the range you want
 Ex: Low = -10.0, High = 10.0
 Set LSPL = -10.0, USPL = 10.0, DP : 000.0

14.4 Steps For Linear Input Calibration

1. Display ANL1, ANH1, DP :

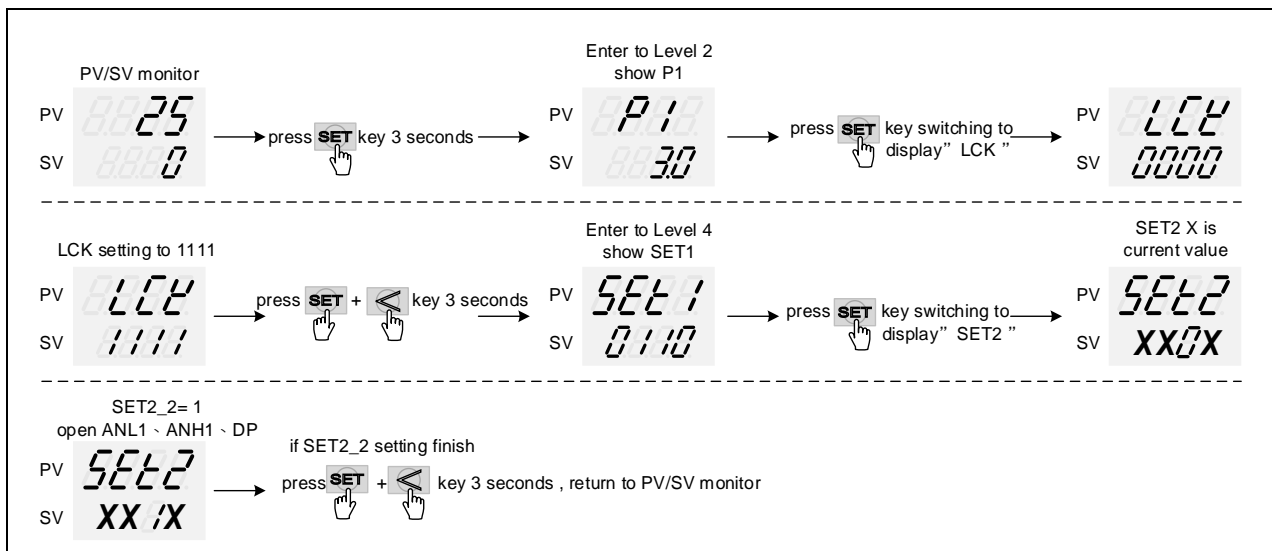

※ X is the default value which does not require modification

2. input 4mA and djust ANL1 calibration values :

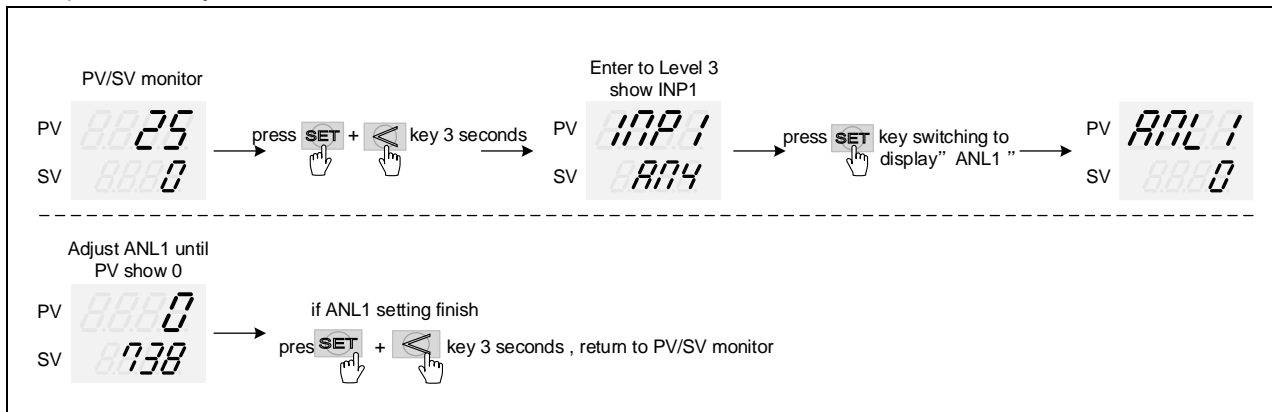

※ ANL1 calibration value of each controller is different from the other

3. input 20mA and djust ANH1 calibration values :

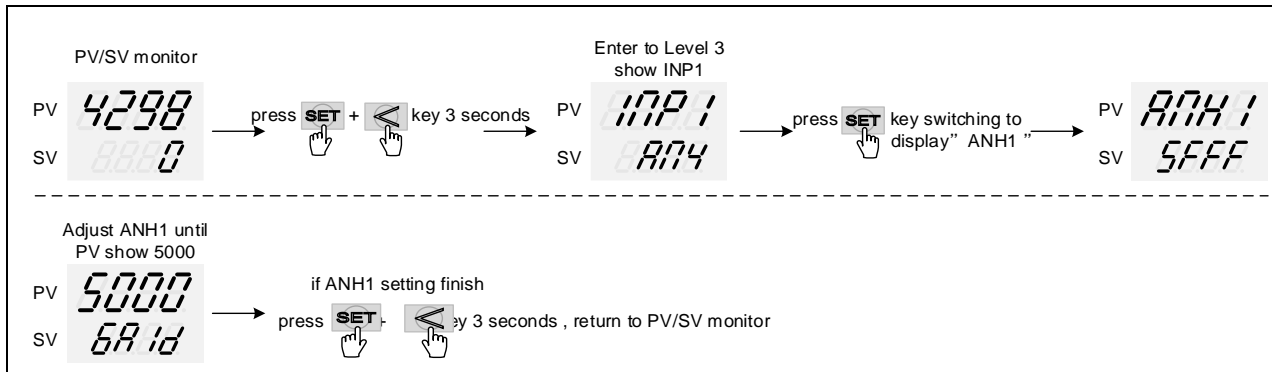

※ ANH1 calibration value of each controller is different from the other



15. Phase angle / Zero cross Control

Description

The FY controller can directly drive the thyristor. In the phase angle control mode, the phase angle of the thyristor can be controlled to cut the sine wave. In the zero cross control mode, it can automatically detect the zero point to turn-on or turn-off sine wave, phase angle control and zero cross control are the use of cutting or turn-on/off the sine wave to achieve the power control.

The advantage of FY controller phase control is that it can be directly used in 380V power systems and automatically detects the voltage phase. Even if the control power supply and heater power supply are different in amplitude or phase, it can still trigger correctly.

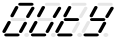
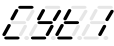

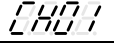
The related parameters of Dehumidification Function are as below:

Parameter	Symbol	Content	Range		Default	Level	Hide/Display
			MAX	MIN			
OUTY		Hardware drive selection 0 : single output control 1 : dual output control 2 : valve control with feedback 3 : valve control without feedback selection 4 : single phase angle control	4	0	0	Level 4	---
CYT1		Main output control cycle 0 : Linear signal 1 : SSR drive 2~150 : Relay	150	0	00	Level 2	---
CLO1		phase angle adjustment	9999	0	0	Level 3	SET4.4
CHO1		phase angle adjustment	9999	0	3600	Level 3	SET4.4

Phase angle control default setting : OUTY=4 、CYT1=0 、CLO1=150 、CHO1=4200

Zero cross control default setting : OUTY=0 、CYT1=1

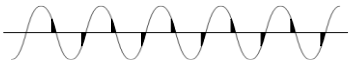
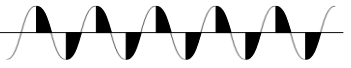
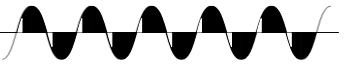
control waveform diagram

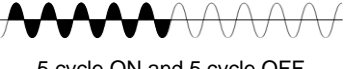
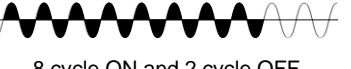
Control	OUT%=10	OUT%=50	OUT%=80
Phase angle control			
Zero crossing control	 1 cycle ON and 9 cycle OFF	 5 cycle ON and 5 cycle OFF	 8 cycle ON and 2 cycle OFF

※ Description of zero cross control

power frequency=50HZ, the period of a sine wave is 20ms.

when the controller is in zero cross control the control period is 200ms

when OUT%=10 : 1 full sine wave is turned on within 200ms, and the remaining 180ms is turned off

when OUT%=50 : 5 full sine wave is turned on within 200ms, and the remaining 100ms is turned off

when OUT%=80 : 8 full sine wave is turned on within 200ms, and the remaining 40ms is turned off

Note

1. Please confirm the jumper position on the phase control board before use. The factory default is 220V. If you want to use a 380V power supply system, please change the jumper position.
2. When single phase angle control is used, CLO1 and CHO1 are used to adjust the phase angle of the thyristor. When the trigger waveform is abnormal, CLO1 can be increased or CHO1 can be reduced to meet the thyristor characteristics
3. When the phase angle control is used, if the load is a bulb, the brightness will change with continuous, and when the zero cross control is used, the brightness will change with flicker

TRIAC Module

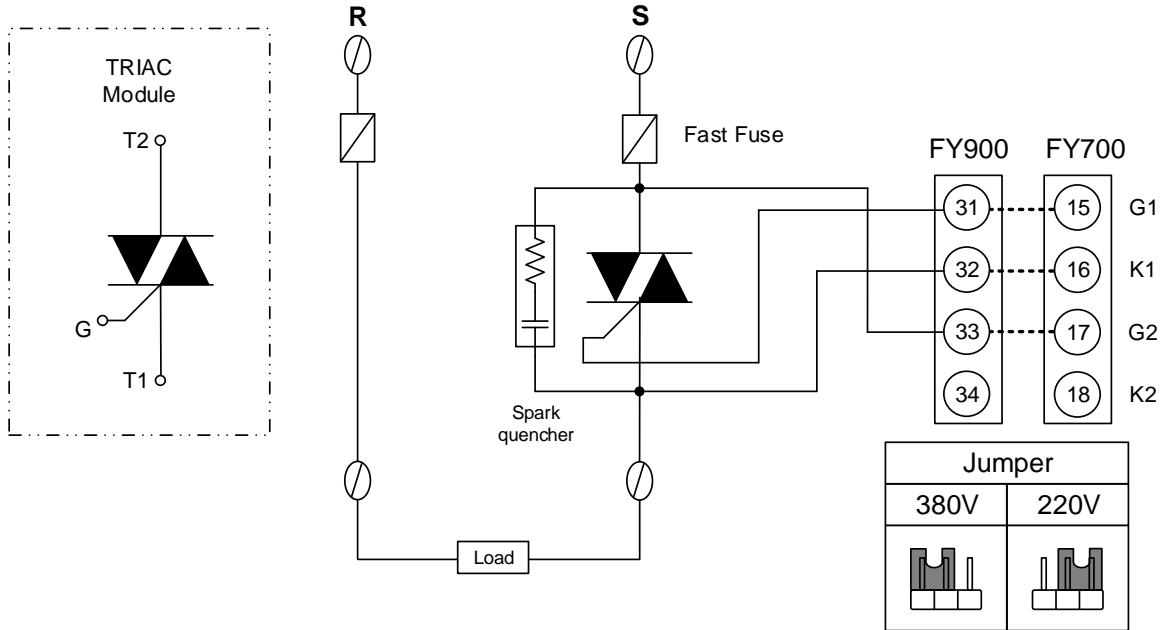

SCR Module

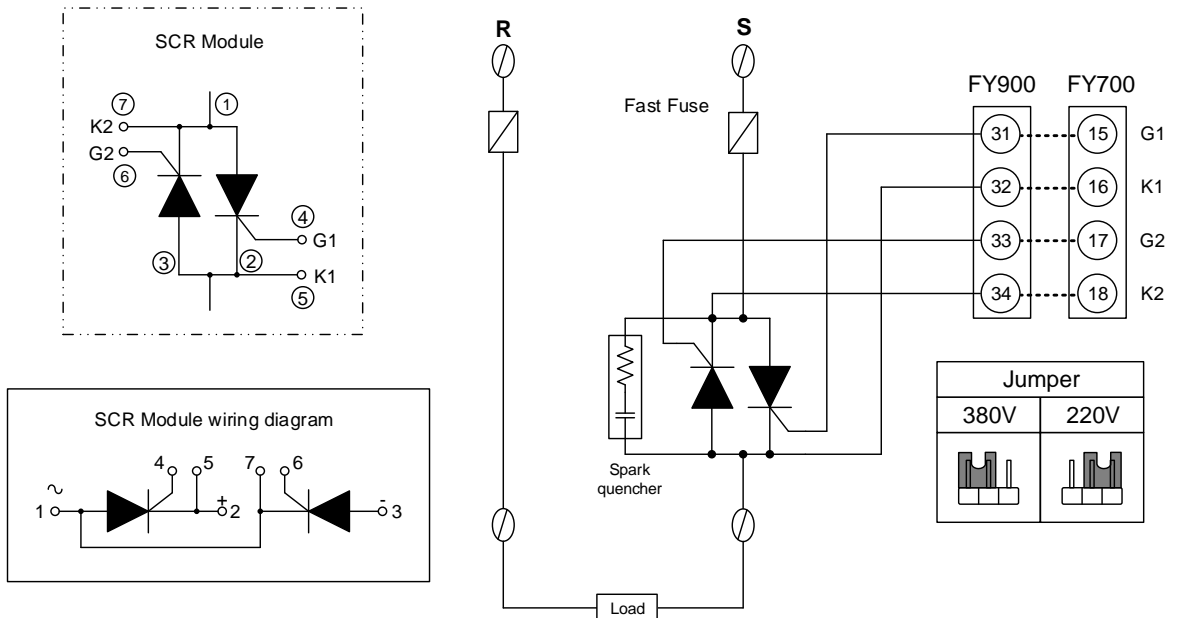

TRIAC Module

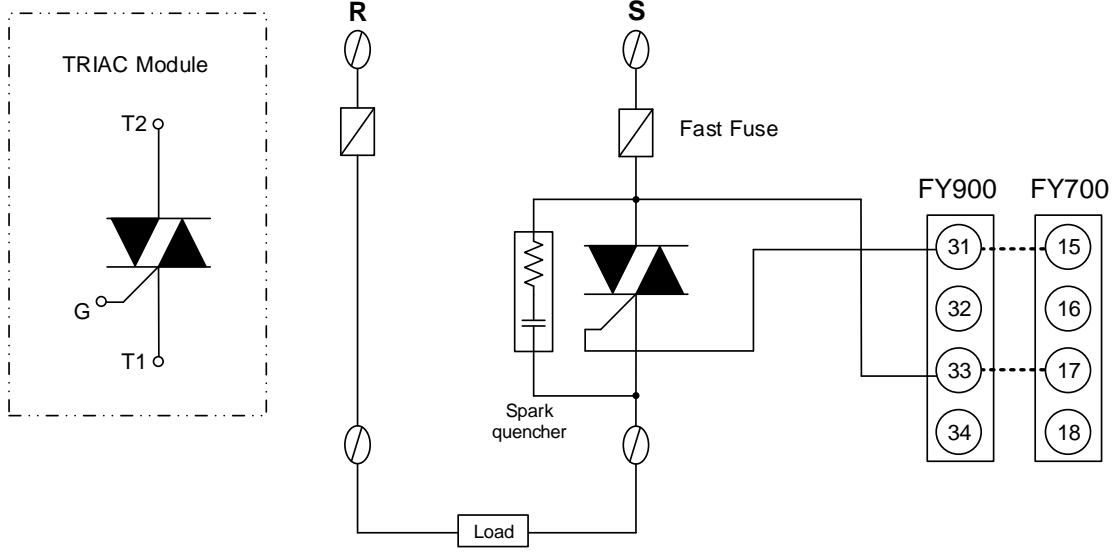

SCR Module

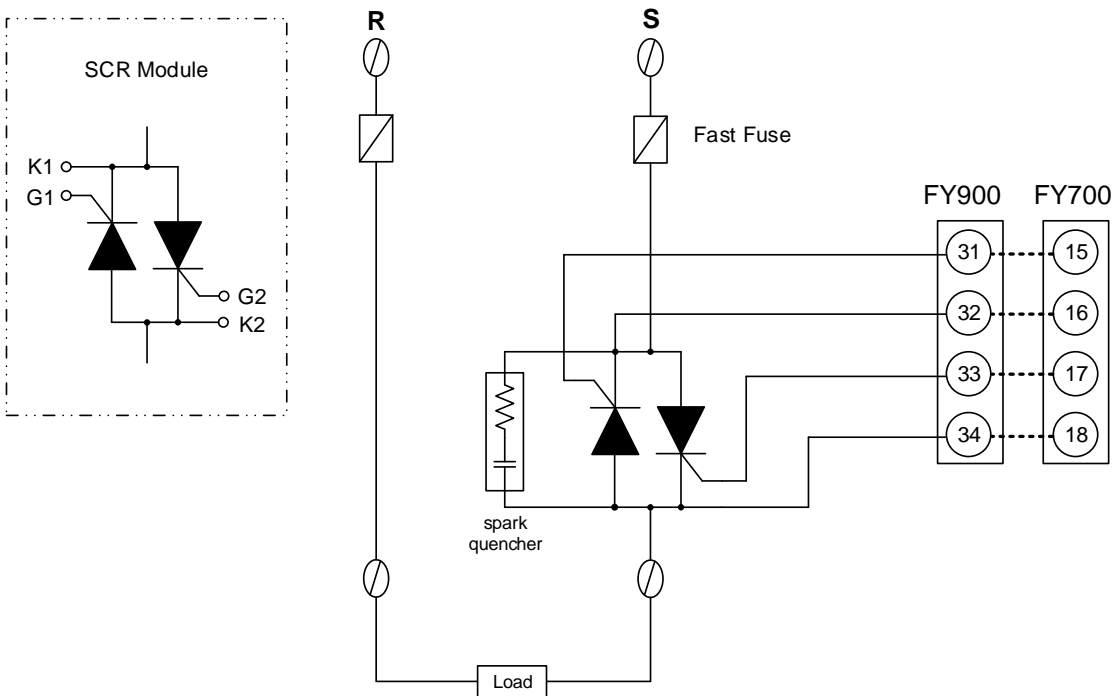

TRIAC Module

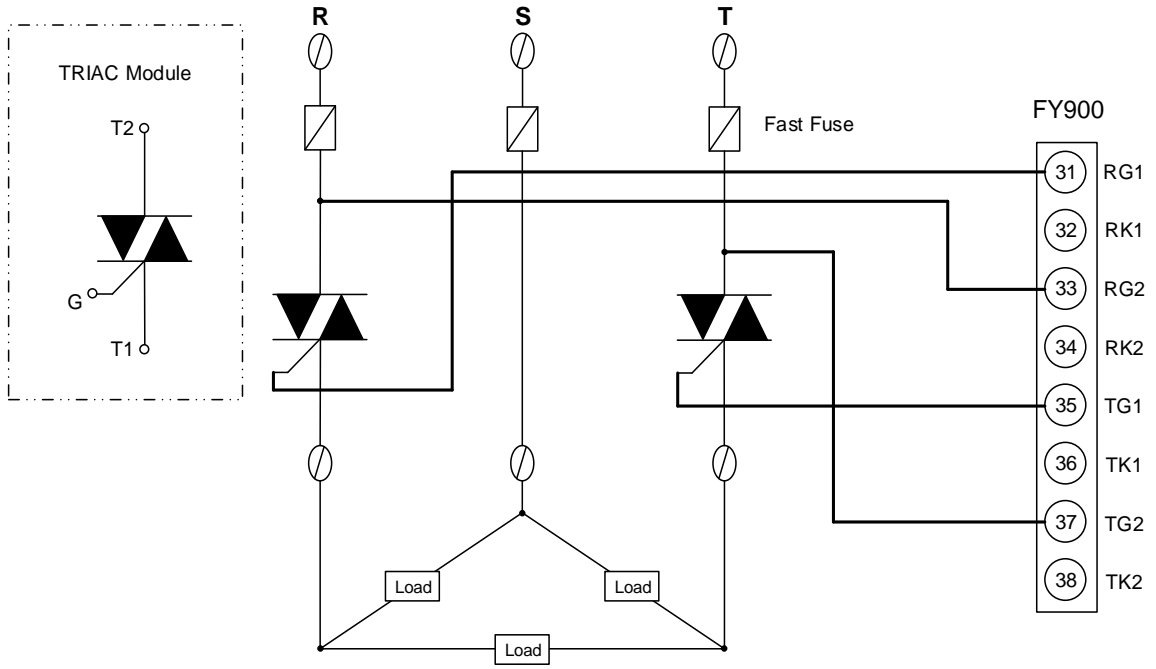

SCR Module

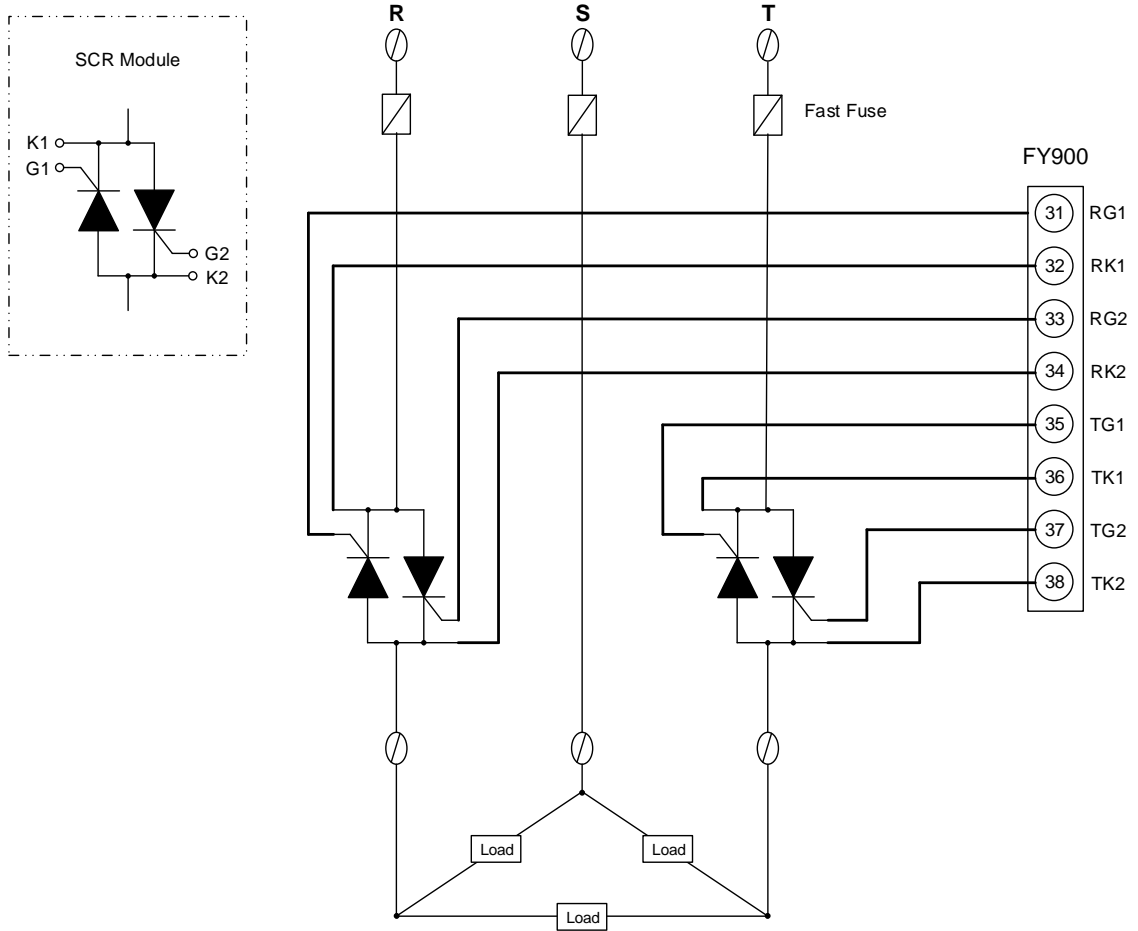

16. Error Message

If the solution is "contact distributor for repair", please do not try to repair it yourself. You can contact the distributor to send it for repair or replace the controller first.

Symbol	Meaning	Cause	Solution
<i>INIE</i>	Input signal error INIE and 7FFF toggle display	Input loop is opened.	Check whether input loop is opened or wiring is incorrect.
<i>7FFF</i>		Controller input circuit failure.	Contact distributor for repair
<i>UUU1</i>	PV above parameter USPL UUU1 and PV toggle display	Input signal greater than USPL	Check whether the input value is correct or not.
<i>NNN1</i>	PV below parameter LSPL NNN1 and PV toggle display	Input signal less than LSPL	Check whether the input value is correct or not.
<i>PMEF</i>	Valve feedback resistor failed. PMEF and PV toggle display	Valve feedback resistor failure	Check whether feedback resistor wiring is incorrect.
<i>AUTF</i>	Auto tuning failed. AUTF and PV toggle display	The auto tuning has been executed for more than 2 hours, and the controller can't calculate the optimal PID value.	Please set the PID value manually or use the default PID control and then fine-tune it.
<i>COMF</i>	Noise interference. COMF and PV toggle display	Nois interferes with RS-485 communication network	<ol style="list-style-type: none"> 1. Add a 110Ω termination resistor to the last device on the RS-485 network. 2. Separate power line and communication line 3. Contact TAIE support
<i>TRSF</i>	Transmission function failed. TRSF and PV toggle display	The controller can't detect the transmission hardware	<ol style="list-style-type: none"> 1. Optional transmission function : Contact distributor for repair 2. NO optional transmission function : Please check whether SET8.3 or SET8.4 is enabled
<i>RAMF</i>	EEPROM failed. RAMF and PV toggle display	The master continues to write new values to a certain parameter more than 1 million times, causing the memory cell to malfunction and unable to memorize it.	<ol style="list-style-type: none"> 1. Contact distributor for repair 2. Please refer to the "EEPROM Protection Mode" chapter of communication manual to avoid this situation from recurring on the controller that has been repaired.
<i>ADCF</i>	A/D convert failed. ADCF and PV toggle display	Controller input circuit failure.	Contact distributor for repair
<i>CJCE</i>	Cold junction compensation failed. CJCE and PV toggle display	Cold junction compensation failed.	Contact distributor for repair
<i>CJOR</i>	Cold junction compensation failed. CJOR and PV toggle display	Cold junction compensation failed.	Contact distributor for repair
<i>CJNR</i>	Cold junction compensation failed. CJNR and PV toggle display	Cold junction compensation failed.	Contact distributor for repair

17. Calibration parameters and experience value list

Description

The FY/FA series controller will calibrate the corresponding signal when leaving the factory according to the analog input or output function ordered by the user.

If the user accidentally adjusts the calibration parameters and cannot restore them, user can first use the experience value in the following table and make detailed adjustments after the controller works normally.

Parameters and corresponding signals

index	Function	Parameter	Signal							
			0-20mA	4-20mA	0-10V	2-10V	0-5V	1-5V	CT : SC80T	CT : SC100T
1	INPUT	ANL1	0	750	-24	934	-20	-840	---	---
		ANH1	5A55	6550	6750	6776	5950	5950	---	---
2	OUTPUT1	CLO1	0	148	0	130	0	110	---	---
		CHO1	4050	3260	3650	3150	3550	2950	---	---
3	OUTPUT2	CLO2	0	155	0	130	0	117	---	---
		CHO2	4050	3450	3650	3150	3550	2950	---	---
4	TRS	CLO3	280	3150	281	2854	282	2680	---	---
		CHO3	4393	3550	3928	3142	3653	2924	---	---
5	Remote SV	ANL2	6	450	9	1046	13	-64	---	---
		ANH2	6414	6530	67F4	67F5	5F6E	5F6E	---	---
6	HBA	ANL2	---	---	---	---	---	---	-180	-232
		ANH2	---	---	---	---	---	---	4F1D	61FD

19. FY/FA Fast Communication Register Address Table

Parameter	Register Address		R / W
	Hex	Dec	
INP1	0x48	72	R / W
RUCY	0x5D	93	R / W
CYT1	0x3E	62	R / W
HYSM	0x44	68	R / W
HYS1	0x3F	63	R / W
PMAC	0x12A	298	R / W
RH.TC	0x12F	303	R / W
RH.PO	0x130	304	R / W
RH.TM	0x131	305	R / W
OPFT	0x12D	301	R / W
PV2	0x68	104	R / W
MOLH	0x01	1	R / W
MOLL	0x12E	302	R / W
PSL	0x60	96	R

Parameter	Register Address		R / W
	Hex	Dec	
BITS	0x61	97	R
IDNO	0x62	98	R
BAUD	0x63	99	R
W_MD	0x119	281	R
MLNB	---	---	---
COMP	---	---	---
OFFS	---	---	---
MV.SF	0x12B	299	R / W
HBOP	0x12C	300	R / W
TRCL	0x132	306	R / W
TRCH	0x133	307	R / W
TP_K	0x121	289	R / W
PVOH	0x134	308	R / W

20. Program Design Table

OUD(control action)	<input type="checkbox"/> HEAT	_____
	<input type="checkbox"/> COOL	_____
WAIT		_____
Program repeat (SET8.1)	<input type="checkbox"/> 0 : not repeat	_____
	<input type="checkbox"/> 1 : repeat	_____
Power failure (SET8.2)	<input type="checkbox"/> 0 : disable	_____
	<input type="checkbox"/> 1 : enable	_____
Program start address (SET8.3)	<input type="checkbox"/> 0 : from zero	_____
	<input type="checkbox"/> 1 : from PV	_____
PVST	<input type="checkbox"/> 0 : FULT	_____
	<input type="checkbox"/> 1 : CUTT	_____
Program time format (SET9.2)	<input type="checkbox"/> 0 : hour.minute	_____
	<input type="checkbox"/> 1 : minute.second	_____

SEG	Parameter	PTN=1	PTN=2	PTN=3	PTN=4	PTN=5	PTN=6
1	SV_1						
	TM_1						
	OUT1						
2	SV_2						
	TM_2						
	OUT2						
3	SV_3						
	TM_3						
	OUT3						
4	SV_4						
	TM_4						
	OUT4						
5	SV_5						
	TM_5						
	OUT5						
6	SV_6						
	TM_6						
	OUT6						
7	SV_7						
	TM_7						
	OUT7						
8	SV_8						
	TM_8						
	OUT8						

SEG	Parameter	PTN=7	PTN=8	PTN=9	PTN=10	PTN=11	PTN=12
1	SV_1						
	TM_1						
	OUT1						
2	SV_2						
	TM_2						
	OUT2						
3	SV_3						
	TM_3						
	OUT3						
4	SV_4						
	TM_4						
	OUT4						
5	SV_5						
	TM_5						
	OUT5						
6	SV_6						
	TM_6						
	OUT6						
7	SV_7						
	TM_7						
	OUT7						
8	SV_8						
	TM_8						
	OUT8						

SEG	Parameter	PTN=13	PTN=14	PTN=15	PTN=16	PTN=17	PTN=18
1	SV_1						
	TM_1						
	OUT1						
2	SV_2						
	TM_2						
	OUT2						
3	SV_3						
	TM_3						
	OUT3						
4	SV_4						
	TM_4						
	OUT4						
5	SV_5						
	TM_5						
	OUT5						
6	SV_6						
	TM_6						
	OUT6						
7	SV_7						
	TM_7						
	OUT7						
8	SV_8						
	TM_8						
	OUT8						

21. Glossary of Characters Used In This Manual

LED Display										
Characters	0	1	2	3	4	5	6	7	8	9
LED Display										
Characters	A	B	C	D	E	F	G	H	I	J
LED Display										
Characters	K	L	M	N	O	P	Q	R	S	T
LED Display										
Characters	U	V	W	Y	Z	°C	°F			



2024.07.02



台灣儀控股份有限公司
TAIWAN INSTRUMENT & CONTROL CO., LTD

Phone: +886-2-8226-1867
Fax: +886-2-8226-1834

E-mail: contact@fa-tale.com.tw
URL: <http://www.fa-tale.com.tw>