

---

*Digital Temperature Controller*  
***FY400/600/700/800/900***  
***FA230/231***

---

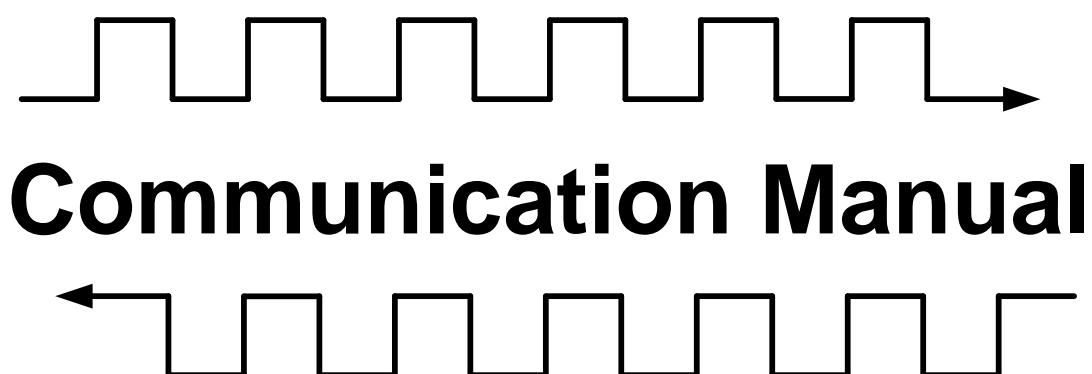

Ver 1.6



台灣儀控股份有限公司  
TAIWAN INSTRUMENT & CONTROL CO., LTD

# Content

1.	Communication Specifications.....	1
2.	System Configuration .....	2
2.1	RS-485 Configuration .....	2
3.	Wiring.....	3
3.1	RS-485 Wiring .....	3
4.	Communication Parameter Setting .....	4
4.1	Setting Communication Parameter .....	4
4.2	Communication Parameter Functionality Outline .....	5
4.3	Procedure for Communication Parameter Setting.....	6
4.4	Master Communication Parameter Setting.....	8
5.	TAIE Protocol .....	10
5.1	Message Structure.....	10
5.2	Read Register Format.....	11
5.3	Write Register Format.....	11
5.4	Modify Register Format.....	11
5.5	More Examples of Read/Write/Modify Example .....	12
5.5.1	Read single register .....	12
5.5.2	Write single register.....	12
5.5.3	Modify single register .....	13
6.	Modbus RTU Protocol .....	14
6.1	Message Structure.....	14
6.2	Read Register Format.....	15
6.2.1	Read single register format .....	15
6.2.2	Read multiple register format .....	16
6.3	Write Register Format.....	16
6.3.1	Write single register format.....	16
6.3.2	Write multiple register format.....	16
6.4	More Examples of Read/Write .....	17
6.4.1	Read single register .....	17
6.4.2	Read multiple register .....	17
6.4.3	Write single register.....	17
6.4.4	Write multiple register.....	18
6.4.5	Via communication read lamp and message .....	19
6.4.6	Via communication control program type controller .....	20
6.5	Error Code .....	23
6.5.1	Read error.....	23

6.5.2	Write error .....	24
6.5.3	Error command .....	24
6.6	EEPROM Protection Function .....	25
7.	Communication Parameter Address .....	25
7.1	General Parameters Address.....	26
7.2	Program Parameters Address.....	35
7.3	Piece Linear Compensation Parameters Address .....	40

## Copyright and Trademark

TAIWAN INSTRUMENT & CONTROL Co., Ltd. owns the copyright of this manual.

- Reproduction of this manual without express permission from TAIWAN INSTRUMENT & CONTROL Co., Ltd. is prohibited.
- Modbus protocol is a communication protocol that Modicon Inc. Developed for PLC and Modbus is a registered trademark of Schneider Electric.
- Other company names and the product names are the trademarks or registered trademarks of each company.
- The On-line CRC calculation and free library is authorized by Mr. Lammert Bies

# 1. Communication Specifications

## TAIE Protocol

Interface	RS-485
Baud rate	2400 bps, 4800 bps, 9600 bps, 19200 bps, 38400 bps, 57600 bps, 115200 bps
Data format	Parity bit : None, Odd, Even Data bit : 8 Stop bit : 1 or 2
Function code	52H : Read single register 4DH : Modify single register 57H : Write single register
Error check	Sum of communication data, with Low Byte as error check.
Maximum connections	Up to 31 units

## MODBUS RTU Protocol

Interface	RS-485
Baud rate	2400 bps, 4800 bps, 9600 bps, 19200 bps, 38400 bps, 57600 bps, 115200 bps
Data format	Parity bit : None, Odd, Even Data bit : 8 Stop bit : 1 or 2
Function code	03H : Read holding registers (max read parameter quantity :100) 06H : Write single register 10H : Write multiple registers (max read parameter quantity : 8)
Error check	CRC-16
Error code	01H : Function code error 02H : Register address error 03H : Data count error
Maximum connections	Up to 31 units

## 2. System Configuration

### 2.1 RS-485 Configuration

MAX number of connection unit for RS-485 communication interface is 31.  
The spanning distance for controller connection PC Cable should not be more than 1200 meters.

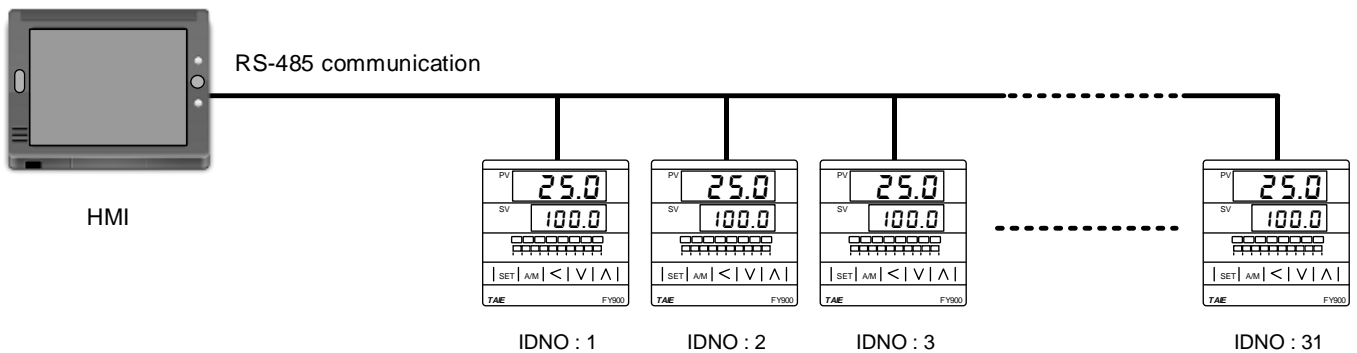
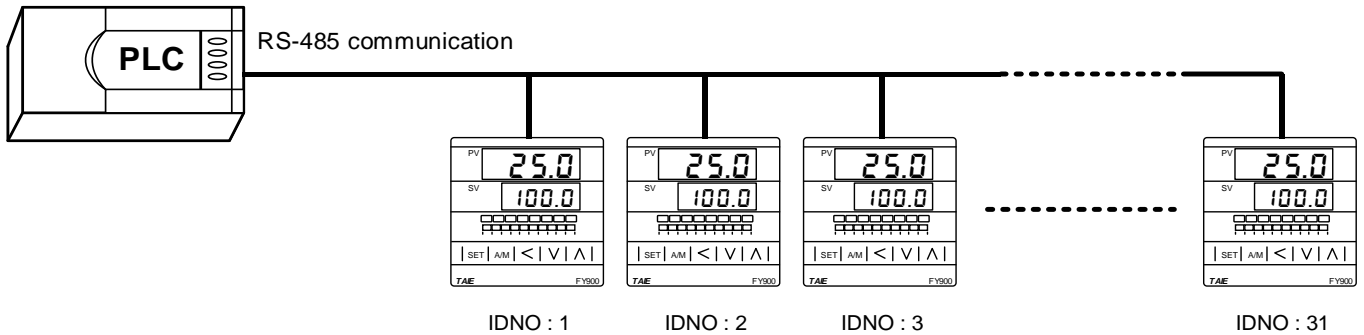
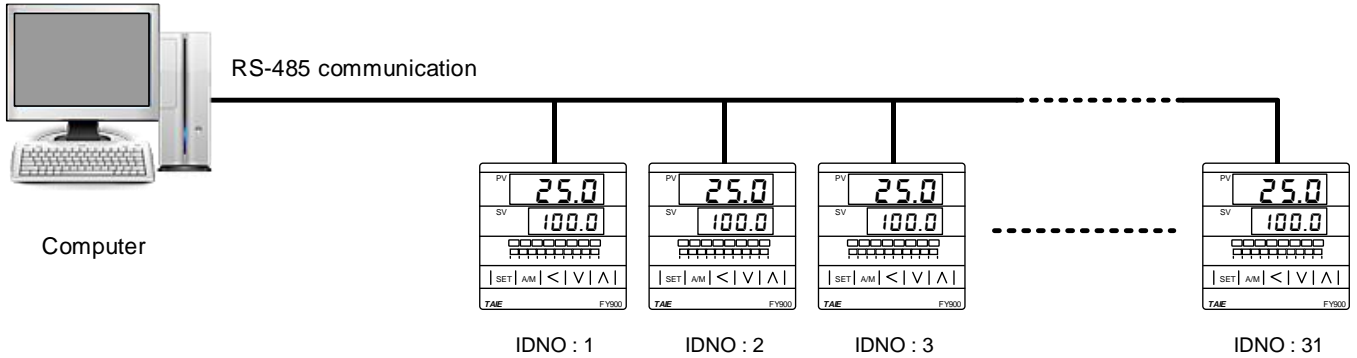

### 3. Wiring

#### 3.1 RS-485 Wiring

Use KA301 Converter to connect with controller

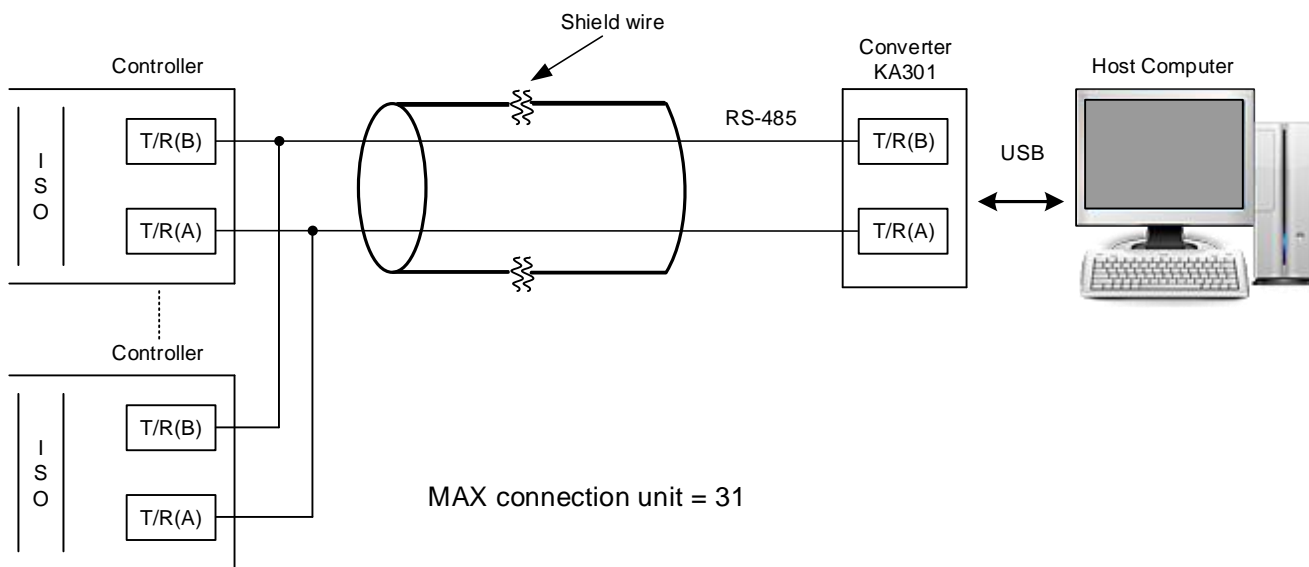

※ The spanning distance for controller connection PC Cable should not be more than 1200 meters.

Use IC485SN Converter connected to controller

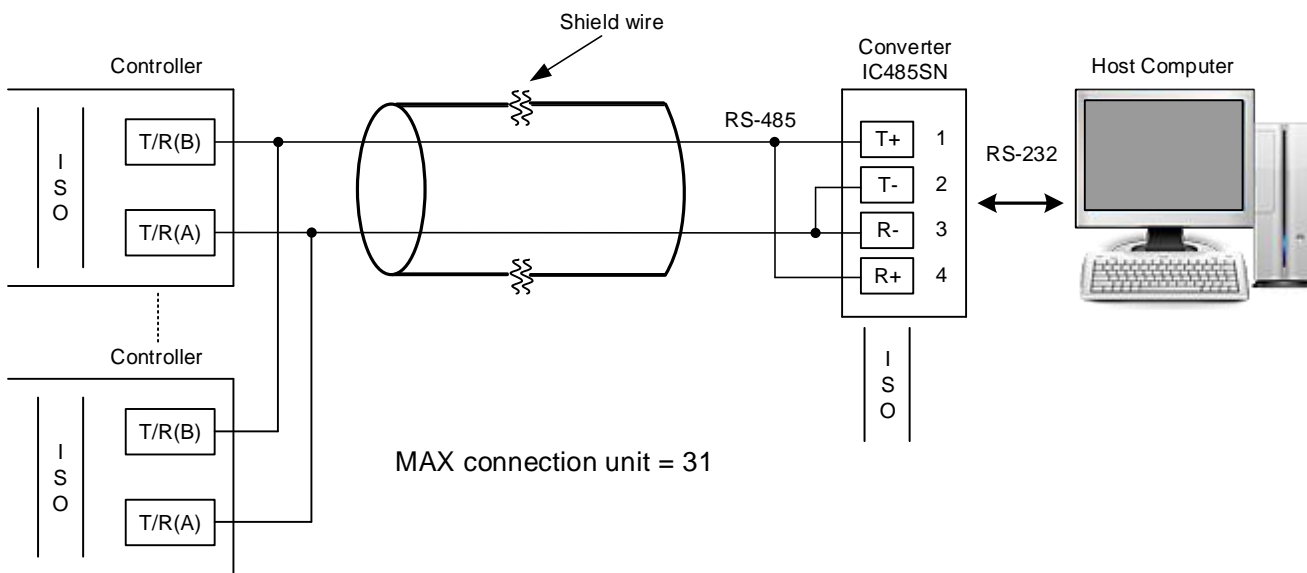

※ The spanning distance for controller connection PC Cable should not be more than 1200 meters.

# 4. Communication Parameter Setting

## 4.1 Setting Communication Parameter

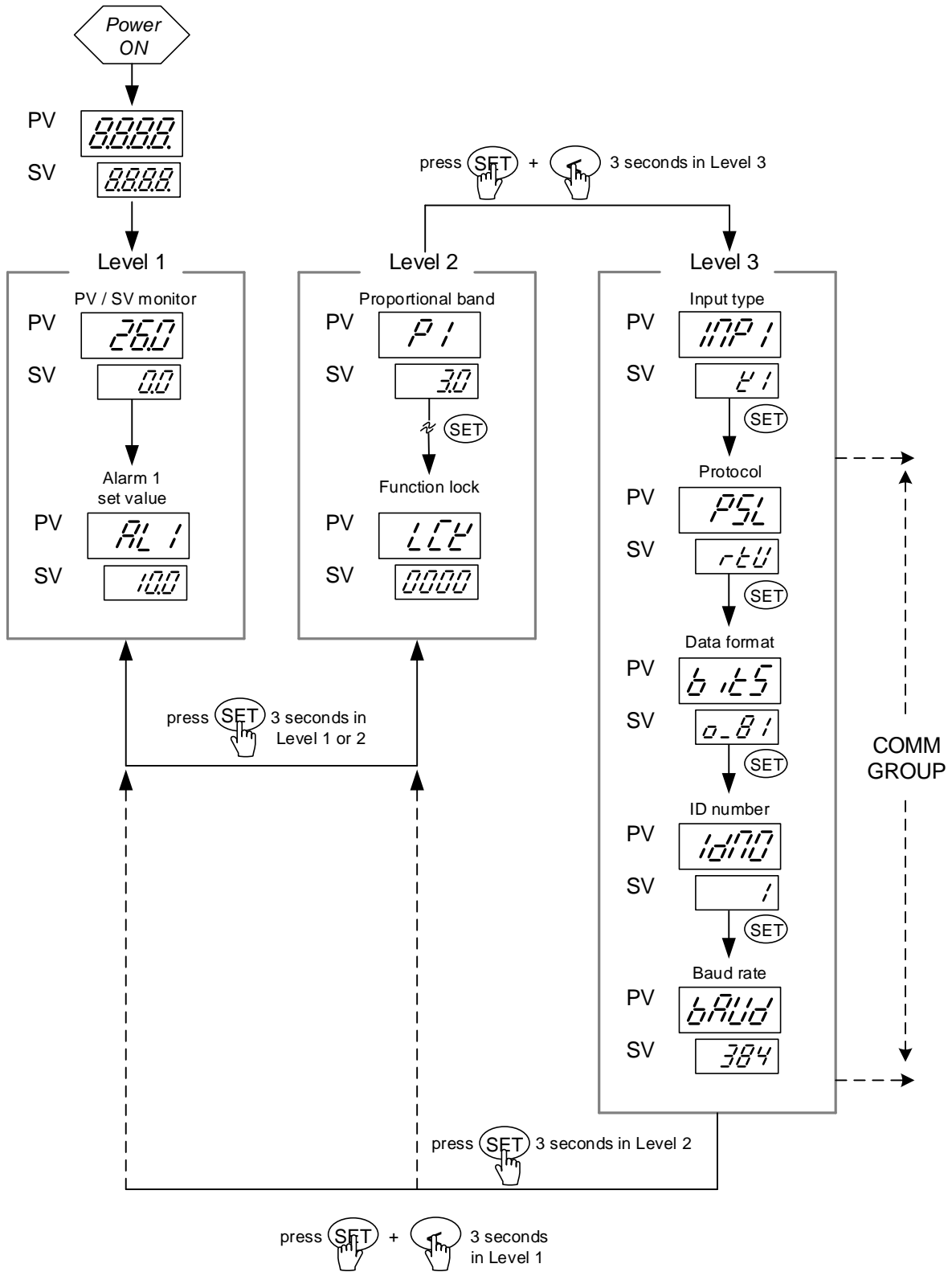



## 4.2 Communication Parameter Functionality Outline

Symbol	Content	Data Range	Default
<i>8P50</i>	Protocol	<i>8RTU</i> : Modbus RTU	<i>8RTU</i>
		<i>8TAIE</i> : TAIE	
<i>6865</i>	Data format	<i>7881</i> : None parity data bits = 8 stop bit = 1	<i>8881</i>
		<i>7882</i> : None parity data bits = 8 stop bit = 2	
		<i>8881</i> : Odd parity data bits = 8 stop bit = 1	
		<i>8882</i> : Odd parity data bits = 8 stop bit = 2	
		<i>8881</i> : Even parity data bits = 8 stop bit = 1	
		<i>8882</i> : Even parity data bits = 8 stop bit = 2	
<i>1870</i>	ID Number	<i>0-254</i> : 0~254	<i>8881</i>
<i>6802</i>	Baud rate	<i>8824</i> : 2400 bps	<i>8384</i>
		<i>8848</i> : 4800 bps	
		<i>8896</i> : 9600 bps	
		<i>8192</i> : 19200 bps	
		<i>8384</i> : 38400 bps	
		<i>8576</i> : 57600 bps	
		<i>1152</i> : 115200 bps	
<i>0808</i>	EEPROM protection	OFF : communication write command only write to CPU RAM	<i>8887</i>
		ON : communication write command write to CPU RAM and EEPROM	

### 4.3 Procedure for Communication Parameter Setting

1. Power ON & Initialization completed

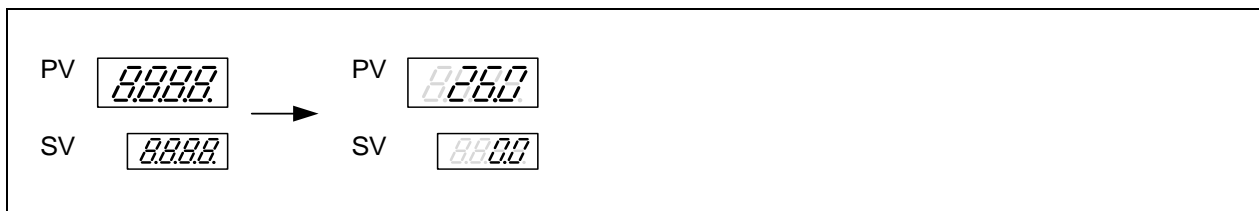

2. Level 1 enter to Level 3, press SET key + SHIFT key for 3 seconds then entering into LEVEL 3

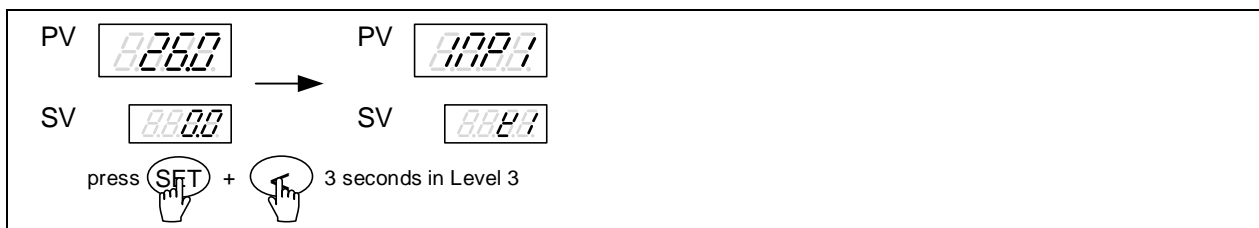

3. Press SET key to search upper display showing the value indicated here. *8P5L*

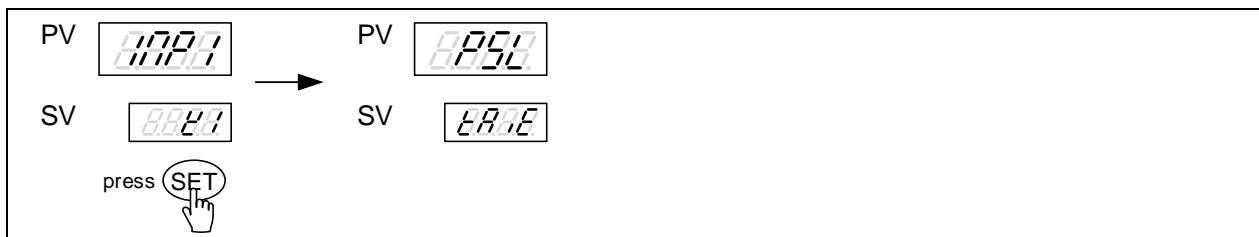

4. Press SHIFT key then lower display will start flash, press UP key or DOWN key to select communication protocol then pressing SET key to save the current setting.

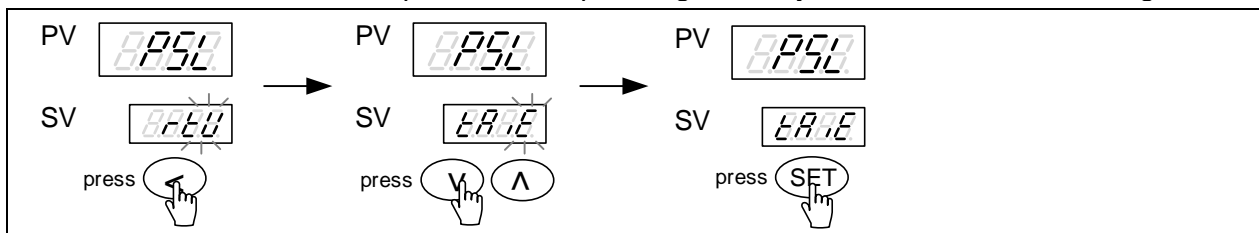

5. Press SET key to search upper display showing the value indicated here. *8885*

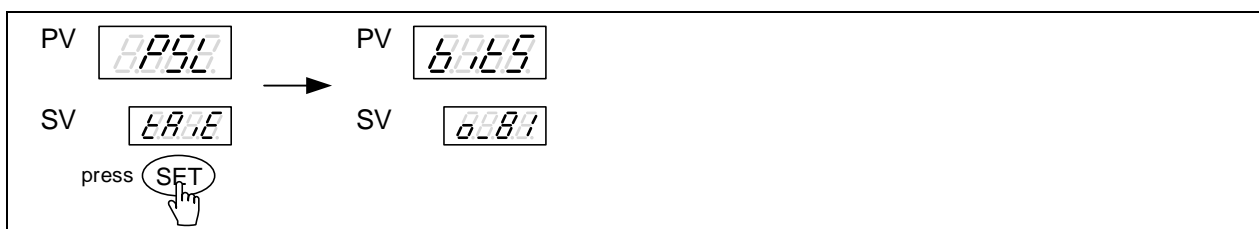

6. Press SHIFT key then lower display will start flash, press UP key or DOWN key to select DATA format then pressing SET key to save the current setting.

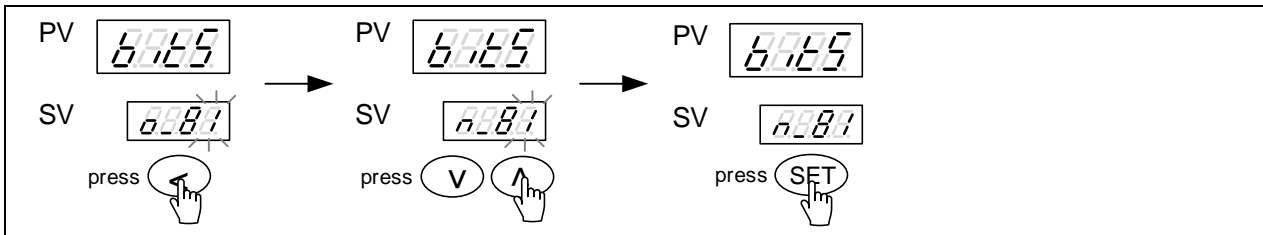

7. Press SET key to search upper display showing the value indicated here. *1000*

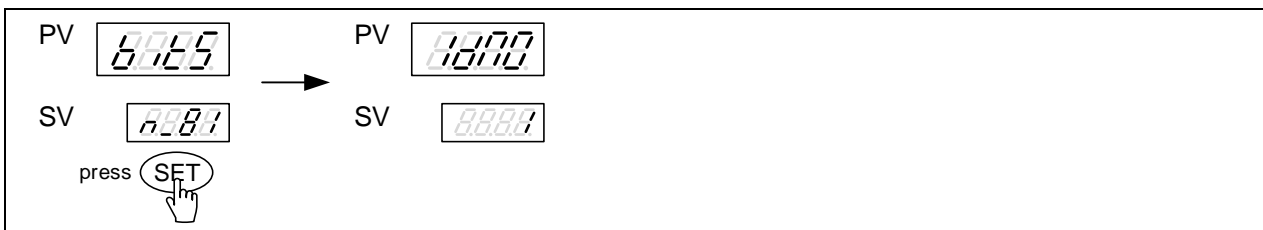

8. Press SHIFT key then lower display will start flash, press UP key or DOWN key to select slave address then pressing SET key to save the current setting.

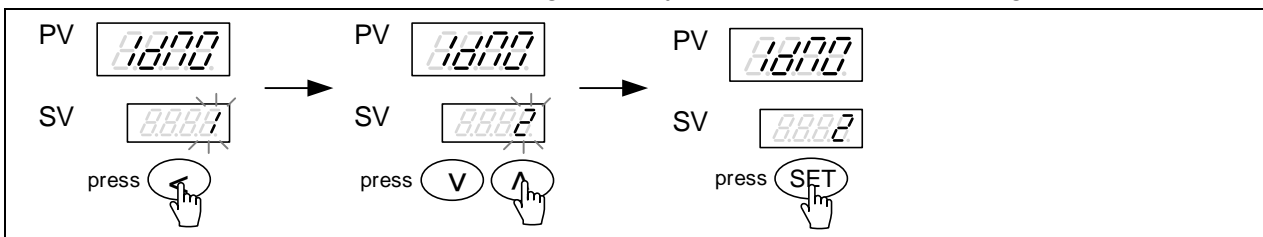

9. Press SET key to search upper display showing the value indicated here. *6900*

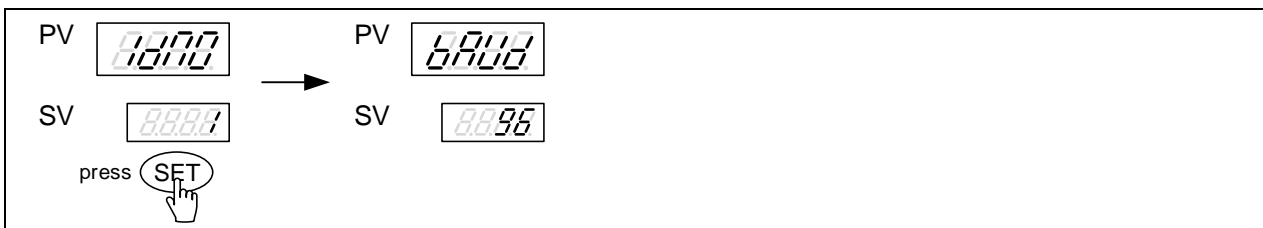

10. Press SHIFT key then lower display will start flash, press UP key or DOWN key to select baud rate then pressing SET key to save the current setting.

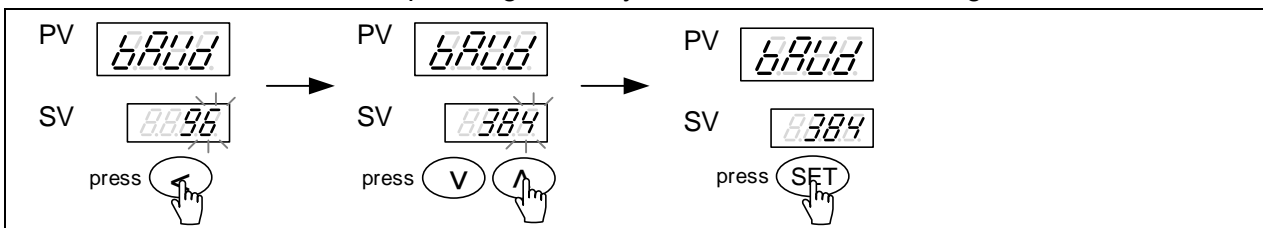

### 4.4 Master Communication Parameter Setting

The host side needs to set the waiting time, timeout time, number of retries. Incorrect settings may cause abnormalities such as read errors and slow write responses. In order to obtain good communication quality, please refer to the following examples to set

Item	Name	Setting value	unit
1	Wait time	50	ms
	Response delay time		
	Delay time		
2	Timeout	1000	ms
3	Retry number	1	---

1. Connect via standard Modbus test software Modbus Poll

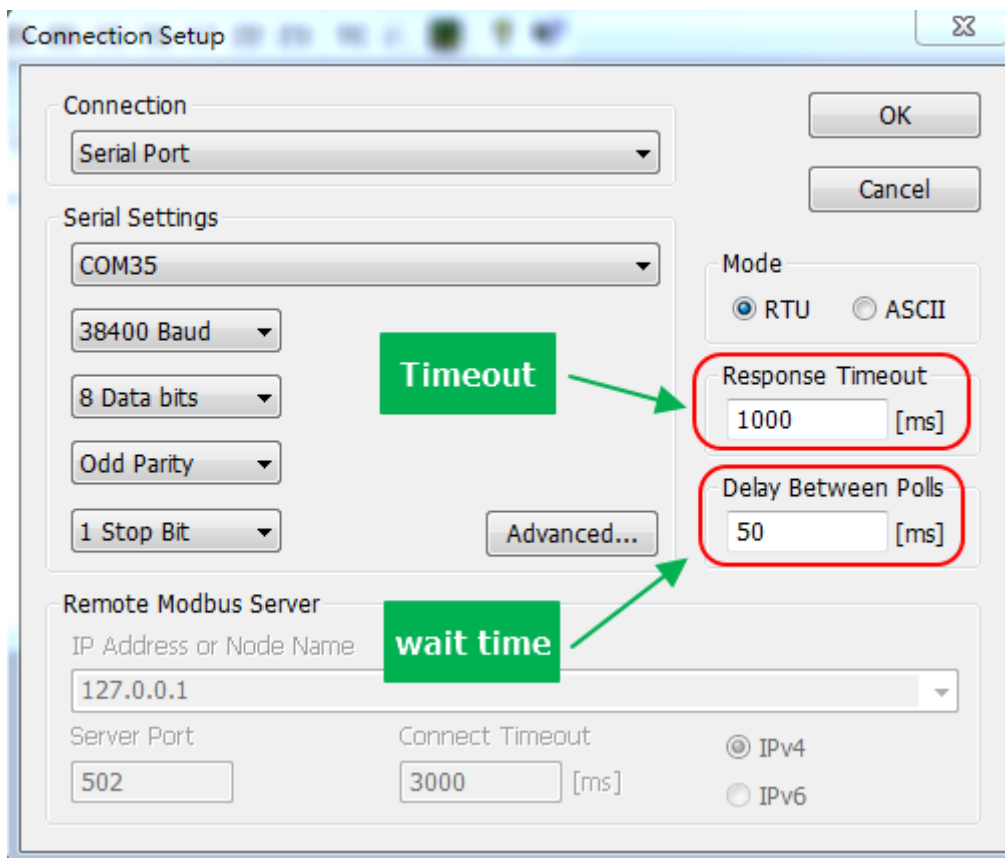

## 2. Connect via Mitsubishi PLC FX-3U

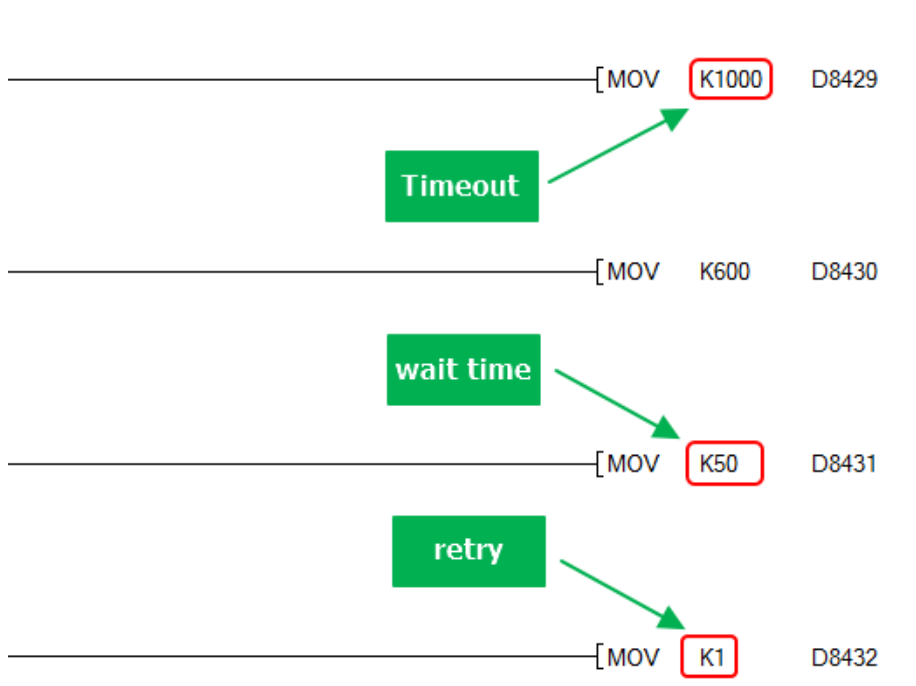

## 3. Connect via Pro-face HMI

Device/PLC 1

Summary [Change Device/PLC](#)

Manufacturer  Series  Port

Text Data Mode  [Change](#)

Communication Settings

SIO Type  RS232C  RS422/485(2wire)  RS422/485(4wire)

Speed

Data Length  7  8

Parity  NONE  EVEN  ODD

Stop Bit  1  2

Flow Control  NONE  FR(DTR/CTS)  XON/XOFF

Timeout  (sec)

Retry

Wait To Send  (ms)  Default Value

Mode  RTU  ASCII

RI / VCC  RI  VCC

In the case of RS232C, you can select the 9th pin to RI (Input) or VCC (5V Power Supply). If you use the Digital's RS232C Isolation Unit, please select it to VCC.

Green boxes with arrows point to the Timeout, Retry, and Wait To Send fields, labeled **Timeout**, **retry**, and **wait time** respectively.

## 5. TAIE Protocol

### 5.1 Message Structure

Function Code
ID number
Data
checksum

#### Function Code

Function Code	Command	Content
'R' (52H)	Read	Reading 1 register value from slave controller.
'M' (4DH)	Modify	Temporarily write 1 register value to controller's RAM. (When reboot the data will be lost)
'W' (57H)	Write	Write 1 register value to controller's RAM and EEPROM. (Data are maintained after power off)

#### Checksum

Add all the values from "Command" to the end of "Data". The result is Checksum (1 byte).

$$\boxed{\text{Command}} + \boxed{\text{ID}} + \boxed{\text{Data Address}} + \boxed{\text{Data}} = \boxed{\text{Checksum}} \rightarrow \boxed{\text{low byte}}$$

※ The Data response not include (Header)07H

EX (1) : Read the SV of controller.

Command	Station	Register Address	Data	Add all	Checksum (get low byte)					
$\boxed{('R')\ 52\ H}$	$+$	$\boxed{01\ H}$	$+$	$\boxed{0000H}$	$+$	$\boxed{03E8\ H}$	$=$	$\boxed{013E\ H}$	$\rightarrow$	$\boxed{3E\ H}$

EX (2) : Temporary write to SV of controller.

Command	Station	Register Address	Data	Add all	Checksum (get low byte)					
$\boxed{('M')\ 4D\ H}$	$+$	$\boxed{01\ H}$	$+$	$\boxed{0000\ H}$	$+$	$\boxed{03E8\ H}$	$=$	$\boxed{0139\ H}$	$\rightarrow$	$\boxed{39\ H}$

EX (3) : Write to SV of controller.

Command	Station	Register Address	Data	Add all	Checksum (get low byte)					
$\boxed{('W')\ 57\ H}$	$+$	$\boxed{01\ H}$	$+$	$\boxed{0000\ H}$	$+$	$\boxed{03E8\ H}$	$=$	$\boxed{0143\ H}$	$\rightarrow$	$\boxed{43\ H}$

## 5.2 Read Register Format

Master send:

Master Send	No. of Byte	1	2	3	4	5	6	7
	Command	<b>52H('R')</b>	<b>01H</b>	<b>00H</b>	<b>00H</b>	<b>00H</b>	<b>00H</b>	<b>53H</b>
	Comment	Read	ID Number	Register Address		Data		Checksum

Controller response:

Controller response	No. of Byte	0	1	2	3	4	5	6	7
	Command	<b>07H</b>	<b>4DH('M')</b>	<b>01H</b>	<b>00H</b>	<b>00H</b>	<b>03H</b>	<b>E8H</b>	<b>39H</b>
	Comment	Header	Read	ID Number	Register Address		Data		Checksum

## 5.3 Write Register Format

Master send:

Master send	No. of Byte	1	2	3	4	5	6	7
	Command	<b>57H('W')</b>	<b>01H</b>	<b>00H</b>	<b>00H</b>	<b>03H</b>	<b>E8H</b>	<b>43H</b>
	Comment	Write	ID Number	Register Address		Data		Checksum

Controller response:

Controller response	No. of Byte	1	2
	Command	<b>4FH('O')</b>	<b>4BH('K')</b>
	Comment	Message	

## 5.4 Modify Register Format

Master send:

Master send	No. of Byte	1	2	3	4	5	6	7
	Command	<b>4DH('M')</b>	<b>01H</b>	<b>00H</b>	<b>00H</b>	<b>00H</b>	<b>64H</b>	<b>B2H</b>
	Comment	Modify	ID Number	Register Address		Data		Checksum

Controller response:

Controller response	No. of Byte	1	2
	Command	<b>4FH('O')</b>	<b>4BH('K')</b>
	Comment	Message	

## 5.5 More Examples of Read/Write/Modify Example

### 5.5.1 Read single register

(1) Read P1, if P1 = 10.0

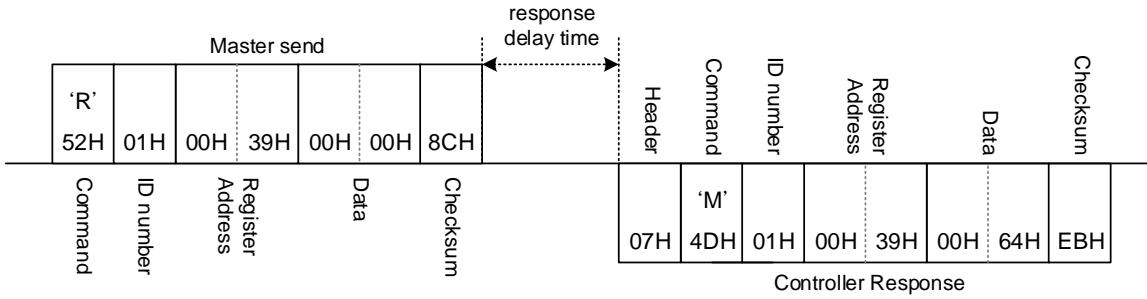

(2) Read AL1, if AL1 = 1234

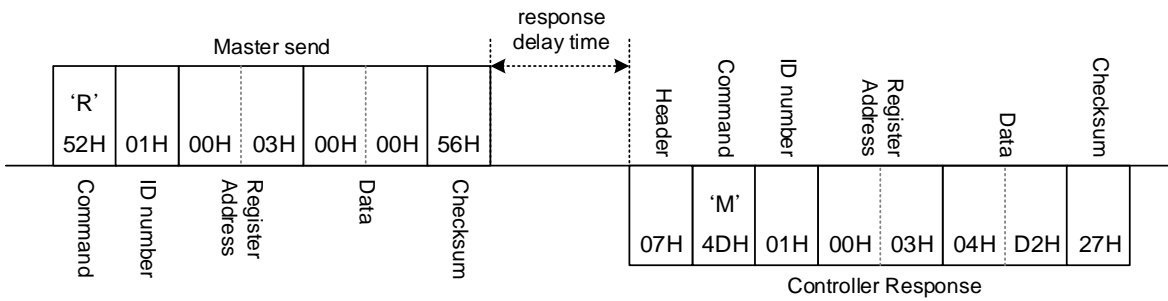

### 5.5.2 Write single register

(1) Write AT = YES

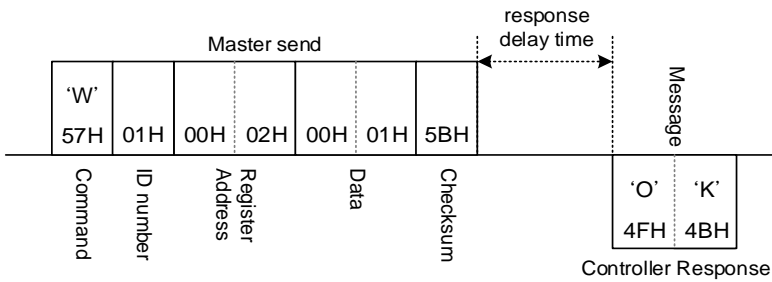

(2) Write CYT1 = 10

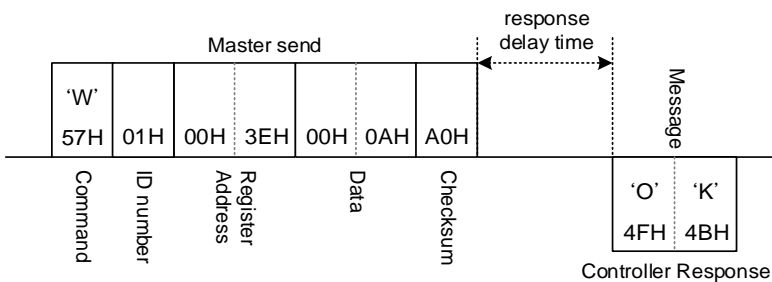



### 5.5.3 Modify single register

(1) Write SV = 500

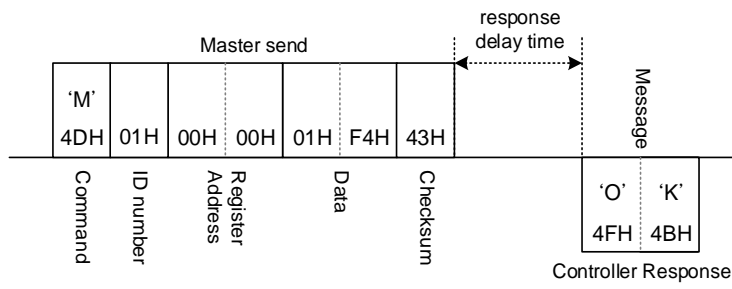

(2) Write AL1 = 50

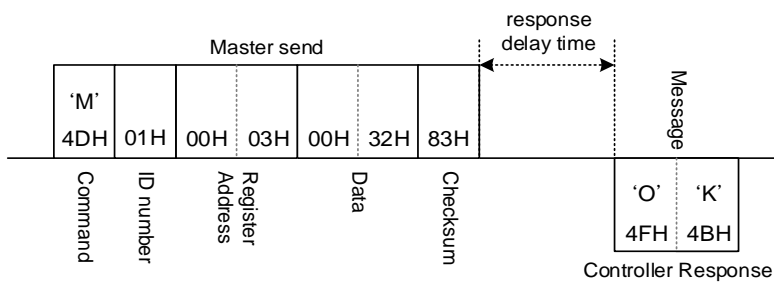

## 6. Modbus RTU Protocol

### 6.1 Message Structure

ID Number
Function Code
Data
CRC-16 Modbus

ID number :  
Controller station number in the RS-485 bus.

Function Code:

Command	Content
03 H	Read holding registers(max read parameter quantity:100)
06 H	Write single register
10 H	Write multiple registers(max write parameter quantity:8)

CRC-16 Modbus:

CRC-16 Modbus generation step are as below:

step 1 : CRC = FFFF(Hex) 2 Byte.

step 2 : Calculate XOR with 1st data (start with n = 1) and the low byte of CRC.

step 3 : If CRC data byte is 1.

→ CRC = CRC >> 1;

CRC^ = 0XA001;

or

→ CRC = CRC >> 1;

step 4 : Repeat step 3, do 8 times.

step 5 : Repeat step 2~4 finished the end of one.

step 6 : Reverse CRC's L/H(Byte), get CRD.

EX(1) Read SV:

No. of Byte	1	2	3	4	5	6	7	8
Command	01 H	03 H	00 H	00 H	00 H	01 H	84H	0A H
Comment	Station	Function Code	Register Address		Data Count		CRC-16 Modbus	

EX(2) Write SV = 1000:

No. of Byte	1	2	3	4	5	6	7	8
Command	01 H	06H	00 H	00 H	03 H	E8 H	89 H	74 H
Comment	Station	Function Code	Register Address		Data Count		CRC-16 Modbus	

EX(3) Write AL1 =10, AL2 = 5:

No. of Byte	1	2	3	4	5	6	7	8	9	10	11	12	13
Command	01 H	10 H	00 H	03H	00 H	02 H	04 H	00 H	0A H	00 H	05 H	53 H	BB H
Comment	Station	Function Code	Register Address		Data Count	Data Byte		Data 1		Data 2		CRC-16 Modbus	

CRC-16 refer to: <http://www.lammertbies.nl/comm/info/crc-calculation.html>

## On-line CRC calculation and free library

- [Introduction on CRC calculations](#)
- [Free CRC calculation routines for download](#)
- [CRC calculation support forum](#) **New**

"010300000001" (hex)	
1 byte checksum	5
CRC-16	0x1184
CRC-16 (Modbus)	0x0A84
CRC-16 (Sick)	0x1108
CRC-CCITT (XModem)	0xBB53
CRC-CCITT (0xFFFF)	0xB543
CRC-CCITT (0x1D0F)	0x8A6D
CRC-CCITT (Kermit)	0x6E08
CRC-DNP	0x4C19
CRC-32	0x4A393840

010300000001

Calculate CRC

Input type:  ASCII  Hex

## 6.2 Read Register Format

### 6.2.1 Read single register format

Master send (Read SV):

Master send	No. of Byte	1	2	3	4	5	6	7	8
	Command	01H	03H	00H	00H	00H	01H	84H	0AH
	Comment	ID Number	Command	Register Address		Data Count		CRC-16 Modbus	

Controller response (If SV = 100.0):

Controller response	No. of Byte	1	2	3	4	5	6	7
	Command	01H	03H	02H	03H	E8H	B8H	FAH
	Comment	ID Number	Command	Register Address		Data Count	CRC-16 Modbus	

### 6.2.2 Read multiple register format

Master send (Read AL1, AL2):

Master send	No. of Byte	1	2	3	4	5	6	7	8
	Command	01H	03H	00H	03H	00H	02H	34H	0BH
	Comment	ID Number	Command	Register Address		Data Count		CRC-16 Modbus	

Controller response:

Controller response	No. of Byte	1	2	3	4	5	6	7	8	9
	Command	01H	03H	04H	00H	0AH	00H	05H	1AH	32H
	Comment	ID Number	Command	Data Byte Count	Data 1		Data 2		CRC-16 Modbus	

## 6.3 Write Register Format

### 6.3.1 Write single register format

Master send (Write SV = 100):

Master send	No. of Byte	1	2	3	4	5	6	7	8
	Command	01H	06H	00H	00H	00H	64H	88H	21H
	Comment	ID Number	Command	Register Address		Data Count		CRC-16 Modbus	

Controller response:

Controller response	No. of Byte	1	2	3	4	5	6	7	8
	Command	01H	06H	00H	00H	00H	64H	88H	21H
	Comment	ID Number	Command	Register Address		Data Count		CRC-16 Modbus	

### 6.3.2 Write multiple register format

Master send (Write AL1 = 10, AL2 = 5):

Master send	No. of Byte	1	2	3	4	5	6	7	8	9	10	11	12	13
	Command	01H	10H	00H	03H	00H	02H	04H	00H	0AH	00H	05H	53H	BBH
	Comment	ID Number	Command	Register Address	Data Count		Data Byte Count	Data 1		Data 2		CRC-16 Modbus		

Controller response:

Controller response	No. of Byte	1	2	3	4	5	6	7	8
	Command	01H	10H	00H	03H	00H	02H	B1H	C8H
	Comment	ID Number	Command	Register Address	Data Count		CRC-16 Modbus		

## 6.4 More Examples of Read/Write

### 6.4.1 Read single register

(1) Read P1, If P1 = 10.0

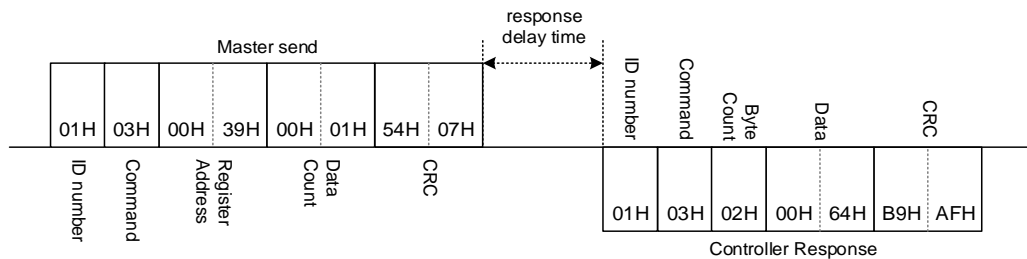

(2) Read AT, If AT = NO

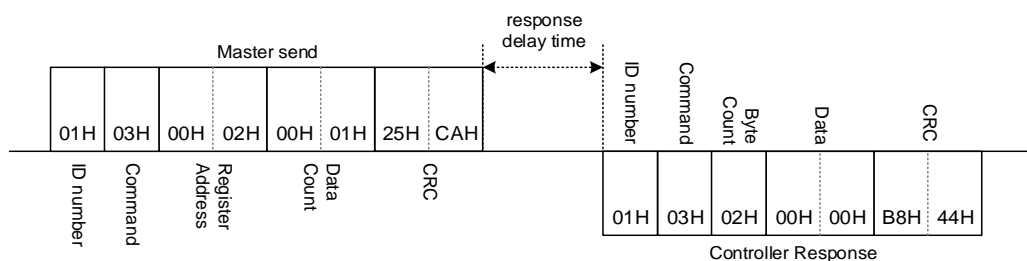

### 6.4.2 Read multiple register

(1) Read AT, AL1, AL2, AL3, If AT = NO, AL1 = 10.0, AL2 = 20.0, AL3 = 30.0

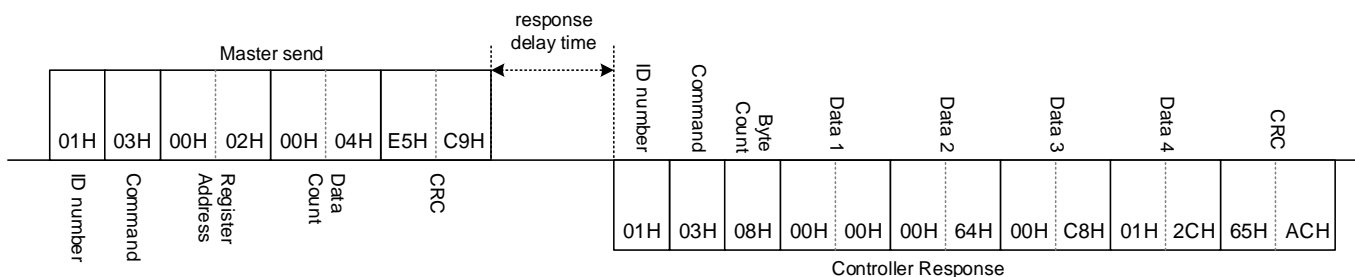

### 6.4.3 Write single register

(1) Write AT = YES

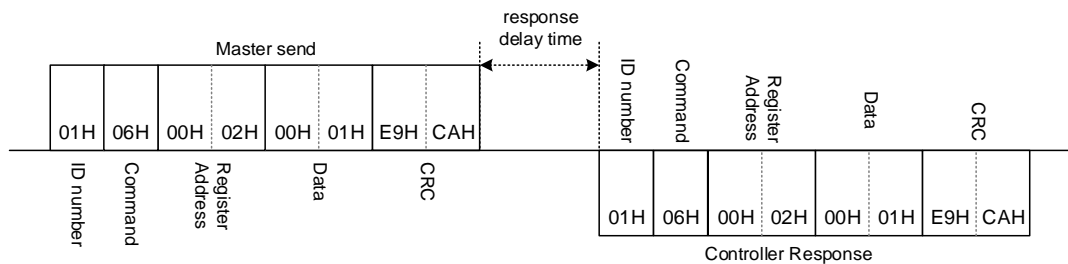

(2) Write CYT1 = 10

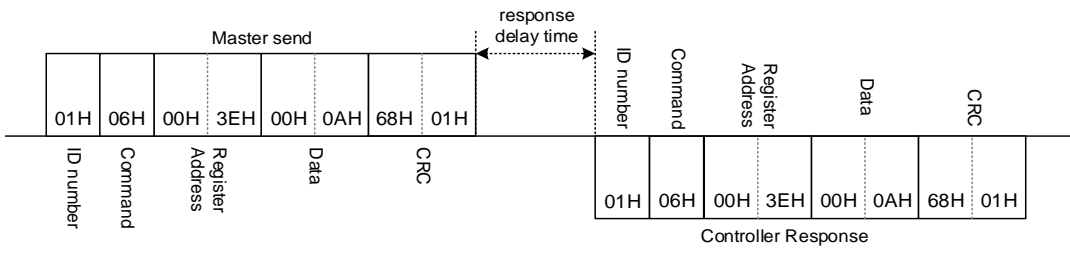

6.4.4 Write multiple register

(1) Continuous write AT, AL1, AL2, AL3, If AT = YES, AL1 = 10.0, AL2 = 20.0, AL3 = 30.0

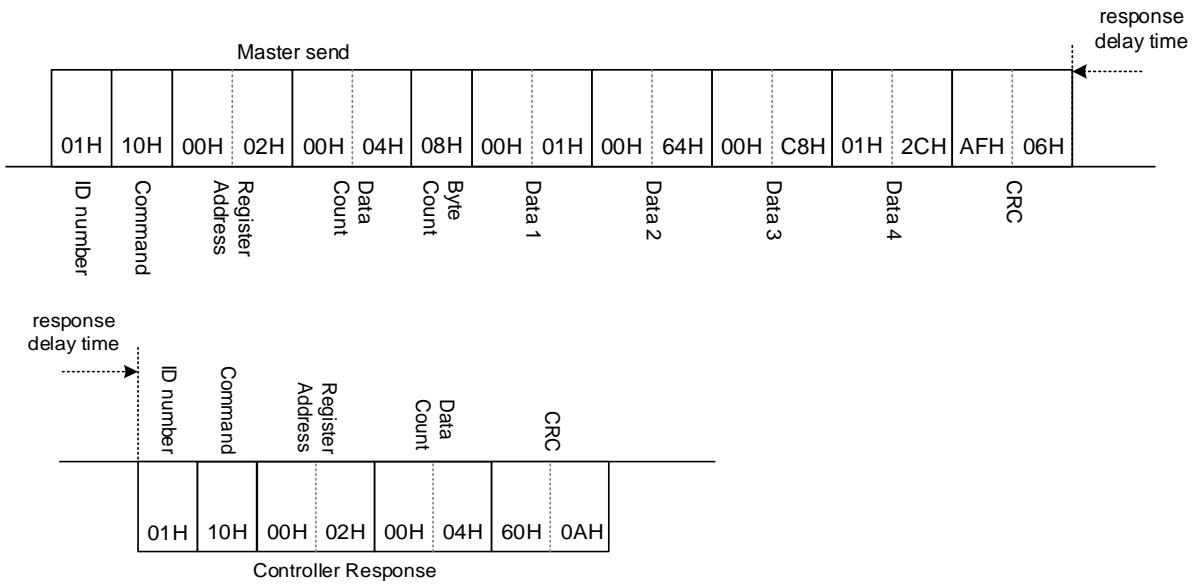

### 6.4.5 Via communication read lamp and message

OBIT is a 16-bit read-only parameter. Each bit has its indicated message or lamp. The lamp status and abnormal message can be read through communication.

Parameter	Content	Range		Address		R/W
		Max	Min	Hex	Dec	
OBIT	Controller Information Bits. $2^0$ = OUT1 $2^1$ = OUT2 $2^2$ = AT $2^3$ = AL1 $2^4$ = AL2 $2^5$ = AL3 $2^6$ = PRO $2^7$ = MAN $2^8$ = IN1E $2^9$ = ADCF $2^{10}$ = CJCE $2^{11}$ = IN2E $2^{12}$ = UUU1 $2^{13}$ = NNN1 $2^{14}$ = UUU2 $2^{15}$ = NNN2	65535	0	0x88	136	R

#### OBIT data format

Bit 15	Bit 14	Bit 13	Bit 12	Bit 11	Bit 10	Bit 9	Bit 8	Bit 7	Bit 6	Bit 5	Bit 4	Bit 3	Bit 2	Bit 1	Bit 0
NNN2	UUU2	NNN1	UUU1	IN2E	CJCE	ADCF	IN1E	MAN	PRO	AL3	AL2	AL1	AT	OUT2	OUT1
$2^{15}$	$2^{14}$	$2^{13}$	$2^{12}$	$2^{11}$	$2^{10}$	$2^9$	$2^8$	$2^7$	$2^6$	$2^5$	$2^4$	$2^3$	$2^2$	$2^1$	$2^0$
32768	16384	8192	4096	2048	1024	512	256	128	64	32	16	8	4	2	1

e.g. OUT1, AL1,AL2,AL2 led lit on  
 OBIT read value  $\rightarrow 1+8+16+32=57$

e.g. OUT1 led lit on and executing auto-tuning  
 OBIT read value  $\rightarrow 1+4=5$

e.g. Input over range, display UUU1 error message, MAN led lit on  
 OBIT read value  $\rightarrow 128+4096=4224$

6.4.6 Via communication control program type controller

1. The upper 8 bits of the parameter LAP1 indicate the status of the program type controller.

Parameter	Content	Range		Address		R/W
		Max	Min	Hex	Dec	
LAP1	message indicator bit 2 <sup>0</sup> = OUT1 2 <sup>1</sup> = OUT2 2 <sup>2</sup> = AT 2 <sup>3</sup> = AL1 2 <sup>4</sup> = AL2 2 <sup>5</sup> = AL3 2 <sup>6</sup> = COM 2 <sup>7</sup> = MAN 2 <sup>8</sup> = Program_Run 2 <sup>9</sup> = Program_End 2 <sup>10</sup> = Program_Wait 2 <sup>11</sup> = r 2 <sup>12</sup> = Program_Halt 2 <sup>13</sup> = r 2 <sup>14</sup> = r 2 <sup>15</sup> = r ※ r : reserve	65535	0	0x408	1032	R

(1) Assuming that the program type controller in Run mode, the read LAP1 data is shown in the figure below.

Bit 15	Bit 14	Bit 13	Bit 12	Bit 11	Bit 10	Bit 9	Bit 8	Bit 7	Bit 6	Bit 5	Bit 4	Bit 3	Bit 2	Bit 1	Bit 0
r	r	r	P_H	r	P_W	P_E	P_R	MAN	PRO	AL3	AL2	AL1	AT	OUT2	OUT1
X	X	X	0	X	0	0	1	X	1	X	X	X	X	X	X

(2) Assuming that the program type controller in Halt mode, the read LAP1 data is shown in the figure below.

Bit 15	Bit 14	Bit 13	Bit 12	Bit 11	Bit 10	Bit 9	Bit 8	Bit 7	Bit 6	Bit 5	Bit 4	Bit 3	Bit 2	Bit 1	Bit 0
r	r	r	P_H	r	P_W	P_E	P_R	MAN	PRO	AL3	AL2	AL1	AT	OUT2	OUT1
X	X	X	1	X	0	0	1	X	1	X	X	X	X	X	X

(3) Assuming that the program type controller in Wait mode, the read LAP1 data is shown in the figure below.

Bit 15	Bit 14	Bit 13	Bit 12	Bit 11	Bit 10	Bit 9	Bit 8	Bit 7	Bit 6	Bit 5	Bit 4	Bit 3	Bit 2	Bit 1	Bit 0
r	r	r	P_H	r	P_W	P_E	P_R	MAN	PRO	AL3	AL2	AL1	AT	OUT2	OUT1
X	X	X	0	X	1	0	1	X	1	X	X	X	X	X	X

(4) Assuming that the program type controller in End mode, the read LAP1 data is shown in the figure below

Bit 15	Bit 14	Bit 13	Bit 12	Bit 11	Bit 10	Bit 9	Bit 8	Bit 7	Bit 6	Bit 5	Bit 4	Bit 3	Bit 2	Bit 1	Bit 0
r	r	r	P_H	r	P_W	P_E	P_R	MAN	PRO	AL3	AL2	AL1	AT	OUT2	OUT1
X	X	X	0	X	0	1	0	X	1	X	X	X	X	X	X

X : don't care



## 2. The upper 8 bits of the parameter PKE1, control program type controller execution status.

Parameter	Content	Range		Address		R/W
		Max	Min	Hex	Dec	
REMO	Remote control program execute 0 : program execute by key 1 : program execute by key or communication	1	0	0x115	277	R/W
PKE1	Program remote control. Use this parameter please make sure REMO=1. 2 <sup>0</sup> = r 2 <sup>1</sup> = r 2 <sup>2</sup> = r 2 <sup>3</sup> = r 2 <sup>4</sup> = r 2 <sup>5</sup> = r 2 <sup>6</sup> = r 2 <sup>7</sup> = r 2 <sup>8</sup> = 256 (RUN) 2 <sup>9</sup> = 512 (HALT) 2 <sup>10</sup> = 1024 (JUMP) 2 <sup>11</sup> = 2048 (RESET) 2 <sup>12</sup> = r 2 <sup>13</sup> = r 2 <sup>14</sup> = r 2 <sup>15</sup> = r ※ r :reserve	65535	0	0x409	1033	W

- (1) Write 256 to PKE1 to start the program
- (2) Write 512 to PKE1 to halt the program
- (3) Write 1024 to PKE1 to jump the program
- (4) Write 2048 to PKE1 to reset the program

## Notes

- ※ Before writing the parameter PKE1, please confirm whether the parameter REMO is 1, if it is 0 please write REMO as 1 first.
- ※ The read value of PKE1 is always 0. If you want to read the current program execution status, please read the parameter LAP1.

## 3. The parameter PTN indicates the current pattern number.

Parameter	Content	Range		Address		R/W
		Max	Min	Hex	Dec	
PTN	Program pattern selection 1~18.	18	1	0x06	6	R/W

## Notes

- ※ PTN can be written only when the controller is in the program not executing state (RESET). writing other values in running mode controller may cause abnormal program execution.
- ※ Write PTN and then start the program, the program will start from the written pattern.  
e.g. Write PTN=3, then write PKE1=256, the controller will execute programs of pattern 3

4. The parameter SEG indicates the current segment number.

Parameter	Content	Range		Address		R/W
		Max	Min	Hex	Dec	
SEG	Current program segment display.	144	1	0x07	7	R

- (1) In the pattern link condition, if 14-segment programs are used, when the program executes to the segment 3 of PTN=2, the SEG reading value at this time is 11  
SEG → 8+3=11
- (2) In the pattern link condition, if 20-segment programs are used, when the program executes to the segment 3 of PTN=3, the SEG reading value at this time is 19  
SEG → 8+8+3=19

5. The parameter TIMR indicates the remaining time of the current segment.

Parameter	Content	Range		Address		R/W
		Max	Min	Hex	Dec	
TIMR	Current segment remain time display. Upper area : display current segment remain time Down area : display current segment executed time	9959	-1	0x08	8	R

- (1) Intuition number display  
When the reading value is 1234, it means that the remaining time of current segment is 12 hours and 34 minutes.  
When the reading value is 28, it means that the remaining time of current segment is 28 minutes.
- (2) When the program in reset mode, the TIMR read value at this time is 0.
- (3) When the program in end mode and the PV display "End" message, the TIMR read value at this time is -1.

## 6.5 Error Code

Code	Content
(01H)	Illegal function code (Non-existent function code)
(02H)	Illegal register address (Register address is out of range)
(03H)	Illegal data count (Data count is out of setting range)

※ 1 is set to the MSB of function code in abnormal status.

### 6.5.1 Read error

#### (1) Register address is out of range

Master send:

Master send	No. of Byte	1	2	3	4	5	6	7	8
	Command	01H	03H	FFH	FFH	00H	01H	2EH	84H
	Comment	ID Number	Command	Register Address(error)		Data Count		CRC-16 Modbus	

Controller response:

Controller response	No. of Byte	1	2	3	6	7
	Command	01H	83H	02H	C0H	F1H
	Comment	ID Number	Command (MSB = 1)	Error Code	CRC-16 Modbus	

#### (2) Data count is out of setting range

Master send:

Master send	No. of Byte	1	2	3	4	5	6	7	8
	Command	01H	03H	00H	00H	00H	6EH	C4H	26H
	Comment	ID Number	Command	Register Address		Data Count (over range)		CRC-16 Modbus	

Controller response:

Controller response	No. of Byte	1	2	3	6	7
	Command	01H	83H	03H	01H	31H
	Comment	ID Number	Command (MSB = 1)	Error Code	CRC-16 Modbus	

## 6.5.2 Write error

## (1) Register address is out of range

Master send:

Master send	No. of Byte	1	2	3	4	5	6	7	8
	Command	01H	06H	FFH	FFH	00H	00H	89H	EEH
	Comment	ID Number	Command	Register Address(error)		Data		CRC-16 Modbus	

Controller response:

Controller response	No. of Byte	1	2	3	6	7
	Command	01H	86H	02H	C3H	A1H
	Comment	ID Number	Command (MSB = 1)	Error Code	CRC-16 Modbus	

## (2) Data count is out of setting range

Master send:

Master send	No. of Byte	1	2	3	4	5	6	7	8	9		
	Command	01H	10H	00H	02H	00	1A	12	00	64		
	Comment	ID Number	Command	Register Address		Data Count (over range)	Data Byte	Data 1	....			

Master send	No. of Byte			24	25	26	27
	Command			00	64	C9	AC
	Comment	...		Data 9	CRC-16 Modbus		

Controller response:

Controller response	No. of Byte	1	2	3	6	7
	Command	01H	90H	03H	0CH	01H
	Comment	ID Number	Command (MSB = 1)	Error Code	CRC-16 Modbus	

## 6.5.3 Error command

## (1) Non-existent function code

Master send:

Master send	No. of Byte	1	2	3	4	5	6	7	8
	Command	01H	00H	00H	00H	00H	01H	C0H	0AH
	Comment	ID Number	Command (error)	Register Address	Data Count		CRC-16 Modbus		

Controller response:

Controller response	No. of Byte	1	2	3	6	7
	Command	01H	80H	01H	80H	00H
	Comment	ID Number	Command (MSB = 1)	Error Code	CRC-16 Modbus	

## 6.6 EEPROM Protection Function

The memory system of the FY/FA series controller is composed of EEPROM, and the number of times and years of memory of the EEPROM has its physical limitations, so a 24C16 EEPROM can be written to about 1 million times. The data retention is about 10 years. If the Master always send write command in high-speed communication, then the EEPROM has a high probability of being over-cycle in a short time, which means that the memory cell failure, the data can't be storage. To prevent this error, the FY/FA series controller provides two protection modes, active protection and passive protection, please refer to the following description.

### (1) Active Protection

The controller will automatically compare the data to be written, whether it is in Modbus RTU or TAIE protocol, when the received data is the same as the last received data, the controller will not write to EEPROM. The controller will only write to the EEPROM when it is different from the last received data.

EX : SV initial value =0, Master continue write to controller's SV

1. Master send SV =1000  
EEPROM : will write to 1000
2. Master send SV =1000  
FY/FA EEPROM : No action
3. Master send SV =1000  
FY/FA EEPROM : No action
4. Master send SV =500  
FY/FA EEPROM : will write to 500
5. Master send SV =500  
FY/FA EEPROM : No action
6. Master send SV =500  
FY/FA EEPROM : No action

### (2) Passive Protection

Set the parameter W\_MD to OFF, when the controller receives the write command, it will only write data to the CPU RAM without writing data to the EEPROM. The advantage of this method is that you don't have to worry about write cycles of EEPROM, and the disadvantage is that the previously written data will not be storage after reboot.

EX1 : Set W\_MD= OFF, SV initial =0, Master send SV =1000

Master send : 01H 06H 00H 00H 03H E8H 89H 74H  
FY/FA RAM (SV) =1000  
FY/FA EEPROM : No action

EX2 : Set W\_MD= ON SV initial =0, Master send SV =1000

Master send : 01H 06H 00H 00H 03H E8H 89H 74H  
FY/FA RAM (SV) =1000  
FY/FA EEPROM : write to 1000

※ This parameter (W\_MD) can't be modify via communication, only available modify by the controller keypad.

## 7. Communication Parameter Address

### 7.1 General Parameters Address

Parameter	Display	Level	Hide/ Display	Content	Range		Address		R/W	Default
					Max	Min	Hex	Dec		
SV	8800	Level 1	---	Set value.	USPL	LSPL	0x00	0	R/W	---
OUTL	000L	Level 1	SET1.1	High limit setting of manipulated value main output. when PID gain > OUTL use OUTL as manipulated value	1000	0	0x01	1	R/W	0
AT	0000	Level 1	SET1.2	Auto-tuning execute selection. 0 : OFF (PID control) 1 : ON (execute auto tuning) 2 : PR.TU (Startup tuning, execute once) 3 : PRTU (Startup tuning, execute always when reboot)	1	0	0x02	2	R/W	0
AL1	0000	Level 1	SET1.3	Alarm1 set value.	USPL	-1999	0x03	3	R/W	10
SOAK	5000	Level 1	ALD1 =10 or ALD1 =19	Alarm1 soak time. Time format : hr.min	9959	0				10
HBAC	0000	Level 1	INP2 =4 or ALD1 =9	HBA current setting value. Upper : heater current display Down : current setting value unit : ampere(A)	1000	0				10
AL2	0000	Level 1	SET1.4	Alarm2 set value.	USPL	-1999	0x04	4	R/W	10
HBAC	0000	Level 1	INP2 =4 or ALD2 =9	HBA current setting value. Upper : heater current display Down : current setting value unit : ampere(A)	1000	0				10
SOAK	5000	Level 1	ALD2 =10 or ALD2 =19	Alarm2 soak time. Time format : hr.min	9959	0				10
AL3	0000	Level 1	SET2.1	Alarm3 set value.	USPL	-1999	0x05	5	R/W	10
SOAK	5000	Level 1	ALD3 =10	Alarm3 soak time. Time format : hr.min	9959	0				10
RAMP	0000	Level 1	ALD3 =10 & SET2.1	The rate of change during SV ramp operation. format : °C / minute	9999	-1999				1000
RATE	0000	Level 1	SET2.1 & SET0.2	Slave SV rate. RATE SV = SV x (RATE/9999)	9999	0				9999
PTN	0000	Level 1	PROG =ON	Program pattern selection 1~18.	18	1	0x06	6	R/W	1
SEG	0000	Level 1	PROG =ON	Current program segment display.	144	1	0x07	7	R	1
TIMR	0000	Level 1	PROG =ON	Current segment remain time display. Upper area : display current segment remain time Down area : display current segment executed time	9959	0	0x08	8	R	---
SV_1	5000	Level 1	PROG =ON	Pattern = 1 Segment 1 SV	USPL	LSPL	0x09	9	R/W	0
TM_1	0000	Level 1	PROG =ON	Pattern = 1 Segment 1 execute time setting, this parameter determines the link between a segment and a segment or pattern and pattern. END(-1) : program end in this segment 00.00 : program step change in this segment 00.01~99.58 : program in this segment execute time 99.59 : program continue execute this segment no end	9959	-1	0x0A	10	R/W	0
OUT1	0000	Level 1	PROG =ON	Pattern = 1 Segment 1 output limit	1000	0	0x0B	11	R/W	1000

Parameter	Display	Level	Hide/ Display	Content	Range		Address		R/W	Default
					Max	Min	Hex	Dec		
SV_2	5002	Level 1	PROG =ON	Pattern = 1 Segment 2 SV.	USPL	LSPL	0x0C	12	R/W	0
TM_2	8002	Level 1	PROG =ON	Pattern = 1 Segment 2 execute time setting.	9959	-1	0x0D	13	R/W	0
OUT2	0002	Level 1	PROG =ON	Pattern = 1 Segment 2 output limit.	1000	0	0x0E	14	R/W	1000
SV_3	5003	Level 1	PROG =ON	Pattern = 1 Segment 3 SV.	USPL	LSPL	0x0F	15	R/W	0
TM_3	8003	Level 1	PROG =ON	Pattern = 1 Segment 3 execute time setting.	9959	-1	0x10	16	R/W	0
OUT3	0003	Level 1	PROG =ON	Pattern = 1 Segment 3 output limit.	1000	0	0x11	17	R/W	1000
SV_4	5004	Level 1	PROG =ON	Pattern = 1 Segment 4 SV.	USPL	LSPL	0x12	18	R/W	0
TM_4	8004	Level 1	PROG =ON	Pattern = 1 Segment 4 execute time setting.	9959	-1	0x13	19	R/W	0
OUT4	0004	Level 1	PROG =ON	Pattern = 1 Segment 4 output limit.	1000	0	0x14	20	R/W	1000
SV_5	5005	Level 1	PROG =ON	Pattern = 1 Segment 5 SV.	USPL	LSPL	0x15	21	R/W	0
TM_5	8005	Level 1	PROG =ON	Pattern = 1 Segment 5 execute time setting.	9959	-1	0x16	22	R/W	0
OUT5	0005	Level 1	PROG =ON	Pattern = 1 Segment 5 output limit.	1000	0	0x17	23	R/W	1000
SV_6	5006	Level 1	PROG =ON	Pattern = 1 Segment 6 SV.	USPL	LSPL	0x18	24	R/W	0
TM_6	8006	Level 1	PROG =ON	Pattern = 1 Segment 6 execute time setting.	9959	-1	0x19	25	R/W	0
OUT6	0006	Level 1	PROG =ON	Pattern = 1 Segment 6 output limit.	1000	0	0x1A	26	R/W	1000
SV_7	5007	Level 1	PROG =ON	Pattern = 1 Segment 7 SV.	USPL	LSPL	0x1B	27	R/W	0
TM_7	8007	Level 1	PROG =ON	Pattern = 1 Segment 7 execute time setting.	9959	-1	0x1C	28	R/W	0
OUT7	0007	Level 1	PROG =ON	Pattern = 1 Segment 7 output limit.	1000	0	0x1D	29	R/W	1000
SV_8	5008	Level 1	PROG =ON	Pattern = 1 Segment 8 SV.	USPL	LSPL	0x1E	30	R/W	0
TM_8	8008	Level 1	PROG =ON	Pattern = 1 Segment 8 execute time setting.	9959	-1	0x1F	31	R/W	0
OUT8	0008	Level 1	PROG =ON	Pattern = 1 Segment 8 output limit.	1000	0	0x20	32	R/W	1000
SV_12	5009	Level 1	PROG =ON	Pattern = 2 Segment 1 SV.	USPL	LSPL	0x21	33	R/W	0
TM_12	8009	Level 1	PROG =ON	Pattern = 2 Segment 1 execute time setting.	9959	-1	0x22	34	R/W	0
OUT12	0009	Level 1	PROG =ON	Pattern = 2 Segment 1 output limit.	1000	0	0x23	35	R/W	1000
SV_22	5010	Level 1	PROG =ON	Pattern = 2 Segment 2 SV.	USPL	LSPL	0x24	36	R/W	0
TM_22	8010	Level 1	PROG =ON	Pattern = 2 Segment 2 execute time setting.	9959	-1	0x25	37	R/W	0
OUT22	0010	Level 1	PROG =ON	Pattern = 2 Segment 2 output limit.	1000	0	0x26	38	R/W	1000
SV_32	5011	Level 1	PROG =ON	Pattern = 2 Segment 3 SV.	USPL	LSPL	0x27	39	R/W	0
TM_32	8011	Level 1	PROG =ON	Pattern = 2 Segment 3 execute time setting.	9959	-1	0x28	40	R/W	0
OUT32	0011	Level 1	PROG =ON	Pattern = 2 Segment 3 output limit.	1000	0	0x29	41	R/W	1000
SV_42	5012	Level 1	PROG =ON	Pattern = 2 Segment 4 SV.	USPL	LSPL	0x2A	42	R/W	0
TM_42	8012	Level 1	PROG =ON	Pattern = 2 Segment 4 execute time setting.	9959	-1	0x2B	43	R/W	0

7. Communication Parameter Address

Parameter	Display	Level	Hide/Display	Content	Range		Address		R/W	Default
					Max	Min	Hex	Dec		
OUT42	00E4	Level 1	PROG =ON	Pattern = 2 Segment 4 output limit.	1000	0	0x2C	44	R/W	1000
SV_52	50E5	Level 1	PROG =ON	Pattern = 2 Segment 5 SV.	USPL	LSPL	0x2D	45	R/W	0
TM_52	E0E5	Level 1	PROG =ON	Pattern = 2 Segment 5 execute time setting.	9959	-1	0x2E	46	R/W	0
OUT52	00E5	Level 1	PROG =ON	Pattern = 2 Segment 5 output limit.	1000	0	0x2F	47	R/W	1000
SV_62	50E6	Level 1	PROG =ON	Pattern = 2 Segment 6 SV.	USPL	LSPL	0x30	48	R/W	0
TM_62	E0E6	Level 1	PROG =ON	Pattern = 2 Segment 6 execute time setting.	9959	-1	0x31	49	R/W	0
OUT62	00E6	Level 1	PROG =ON	Pattern = 2 Segment 6 output limit.	1000	0	0x32	50	R/W	1000
SV_72	50E7	Level 1	PROG =ON	Pattern = 2 Segment 7 SV.	USPL	LSPL	0x33	51	R/W	0
TM_72	E0E7	Level 1	PROG =ON	Pattern = 2 Segment 7 execute time setting.	9959	-1	0x34	52	R/W	0
OUT72	00E7	Level 1	PROG =ON	Pattern = 2 Segment 7 output limit.	1000	0	0x35	53	R/W	1000
SV_82	50E8	Level 1	PROG =ON	Pattern = 2 Segment 8 SV.	USPL	LSPL	0x36	54	R/W	0
TM_82	E0E8	Level 1	PROG =ON	Pattern = 2 Segment 8 execute time setting.	9959	-1	0x37	55	R/W	0
OUT82	00E8	Level 1	PROG =ON	Pattern = 2 Segment 8 output limit.	1000	0	0x38	56	R/W	1000
P1	P1	Level 2	--	Main output proportional band. 0.0 : ON/OFF control Other values : proportional band setting value	200.0	0.0	0x39	57	R/W	3.0
I1	I1	Level 2	--	Main output integral time. 0 : disable integral function Other values : integral time setting value	3600	0	0x3A	58	R/W	240
D1	D1	Level 2	--	Main output derivative time. 0 : disable derivative function Other values : derivative time setting value	900	0	0x3B	59	R/W	60
AT.VL	AT.VL	Level 2	--	Auto tuning offset value. execute auto tuning in (SV+ATVL) point	100.0	-100.0	0x3D	61	R/W	0.0
CYT1	CYT1	Level 2	--	Main output control cycle. 0 : Linear signal 1 : SSR drive 2~150 : Relay	150	0	0x3E	62	R/W	10
HYS1	HYS1	Level 2	P1 =0.0	Hysteresis for main output. on/off control use(when P1 = 0.0 appear) heating formula : $PV \geq (SV + HYS1) \rightarrow OUT1 = OFF$ $PV \leq (SV - HYS1) \rightarrow OUT1 = ON$ cooling formula : $PV \geq (SV + HYS1) \rightarrow OUT1 = ON$ $PV \leq (SV - HYS1) \rightarrow OUT1 = OFF$	100.0	-100.0	0x3F	63	R/W	1.0
P2	P2	Level 2	OUTY =1	Sub output proportional band. 0.0 : ON/OFF control Other values : proportional band setting value	200.0	0.0	0x40	64	R/W	3.0
I2	I2	Level 2	OUTY =1	Sub output integral time. 0 : disable integral function Other values : integral time setting value	3600	0	0x41	65	R/W	240
D2	D2	Level 2	OUTY =1	Sub output derivative time. 0 : disable derivative function Other values : derivative time setting value	900	0	0x42	66	R/W	60
CYT2	CYT2	Level 2	OUTY =1	Sub output control cycle. 0 : Linear signal 1 : SSR drive 2~150 : Relay	150	0	0x43	67	R/W	10



Parameter	Display	Level	Hide/ Display	Content	Range		Address		R/W	Default
					Max	Min	Hex	Dec		
HYS2		Level 2	P2 =0.0	Hysteresis for sub output. on/off control use(when P2 = 0.0 appear)	100.0	-100.0	0x44	68	R/W	1.0
GAP1		Level 2	OUTY =1	Control gap (for main output)	1000	-1000	0x45	69	R/W	0
GAP2		Level 2	OUTY =1	Control gap (for sub output)	1000	-1000	0x46	70	R/W	0
LCK		Level 2	---	Function or level lock. 0000 = 0 0001 = 1 0010 = 16 0011 = 17 0100 = 256 0101 = 257 0110 = 272 0111 = 273 1000 = 4096 1001 = 4097 1010 = 4112 1011 = 4113 1100 = 4352 1101 = 4353 1110 = 4368 1111 = 4369	4369	0	0x47	71	R/W	0
INP1		Level 3	---	Main input type selection Change this parameter USPL & LSPL will be reset. 0 : K1 (-50.0~600.0°C) 1 : K2 (-50~1200°C) 2 : J1 (-50.0~400.0°C) 3 : J2 (-50~400°C) 4 : R (-50~1760°C) 5 : S (-50~1760°C) 6 : B (-50~1820°C) 7 : E (-50~900°C) 8 : N (-50~1300°C) 9 : T1 (-199.9~400.0°C) 10 : T2 (-199~400°C) 11 : W (-50~2320°C) 12 : PL (-50~1200°C) 13 : L (-50~800°C) 14 : PT1 (-199.9~850.0°C) 15 : PT2 (-199~850°C) 16 : PT3 (0~850°C) 17 : AN1 18 : AN2 19 : AN3 20 : AN4	AN4	K1	0x48	72	R/W	K1
ANL1		Level 3	SET2.2	Main input zero calibration. (only available in linear input)	9999	-1999	0x49	73	R/W	0
ANH1		Level 3	SET2.2	Main input span calibration. (hex display) (only available in linear input)	0x7FFF	0x0000	0x4A	74	R/W	0x5FFF
DP		Level 3	SET2.2	Decimal point position (only available in linear signal input AN1~AN4) 0 : 0000 1 : 000.0 2 : 00.00 3 : 0.000	3	0	0x4B	75	R/W	1
LSPL		Level 3	SET2.3	Input scale low.	9999	-1999	0x4C	76	R/W	---
USPL		Level 3	SET2.3	Input scale high.	9999	-1999	0x4D	77	R/W	---
ANL2		Level 3	SET2.4	Sub input zero calibration.	9999	-1999	0x4E	78	R/W	0
ANH2		Level 3	SET2.4	Sub input span calibration (hex display)	0x7FFF	0x0000	0x4F	79	R/W	0x5FFF

## 7. Communication Parameter Address

Parameter	Display	Level	Hide/ Display	Content	Range		Address		R/W	Default
					Max	Min	Hex	Dec		
ALD1	ALD1	Level 3	SET3.1	Alarm1 mode selection. 0 : No alarm function 1 : Deviation high (With hold action) 2 : Deviation low (With hold action) 3 : Deviation high / low (With hold action) 4 : Band (With hold action) 5 : Process high (With hold action) 6 : Process low (With hold action) 7 : Program segment execute alarm 8 : System error 9 : HBA (Heater Break Alarm) 10 : SOAK_A 11 : Deviation high 12 : Deviation low 13 : Deviation high / low 14 : Band 15 : Process high 16 : Process low 17 : Program run/end 18 : System normal 19 : SOAK_B	19	0	0x50	80	R/W	11
ALT1	ALT1	Level 3	SET3.2	Alarm1 time setting. 0 : Flicker 99.59 : Continued ON 00.01~99.58 : delay time Time format : min . sec	9959	0	0x51	81	R/W	9959
ALD2	ALD2	Level 3	SET3.3	Alarm2 mode selection (refer to ALD1)	19	0	0x52	82	R/W	0
ALT2	ALT2	Level 3	SET3.4	Alarm2 time setting. 0 : Flicker 99.59 : Continued ON 00.01~99.58 : delay time Time format : min . sec	9959	0	0x53	83	R/W	9959
ALD3	ALD3	Level 3	SET4.1	Alarm3 mode selection (refer to ALD1)	18	0	0x54	84	R/W	0
ALT3	ALT3	Level 3	SET4.2	Alarm3 time setting. 0 : Flicker 99.59 : Continued ON 00.01~99.58 : delay time Time format : min . sec	9959	00	0x55	85	R/W	9959
HYSA	HYSA	Level 3	SET4.3	Hysteresis setting for alarm1~3.	9999	-1999	0x56	86	R/W	10
CLO1	CLO1	Level 3	SET4.4	Main output zero calibration only for linear signal.	9999	0	0x57	87	R/W	0
CHO1	CHO1	Level 3	SET4.4	Main output span calibration only for linear signal.	9999	0	0x58	88	R/W	3600
CLO2	CLO2	Level 3	SET5.1	Sub output zero calibration only for linear signal.	9999	0	0x59	89	R/W	0
CHO2	CHO2	Level 3	SET5.1	Sub output span calibration only for linear signal.	9999	0	0x5A	90	R/W	3600
CLO3	CLO3	Level 3	SET5.2	Retransmission zero calibration.	9999	0	0x5B	91	R/W	0
CHO3	CHO3	Level 3	SET5.2	Retransmission span calibration.	9999	0	0x5C	92	R/W	3600
RUCY	RUCY	Level 3	SET5.3	Motor valve traveling time. unit : second	150	5	0x5D	93	R/W	5
WAIT	WAIT	Level 3	SET5.3	Program execution standby temperature. 0 : when program executed reach SV do not waiting for PV temperature Other values : when PV = (target SV-WAIT), program entering next segment	1000	0	0x5E	94	R/W	0

Parameter	Display	Level	Hide/ Display	Content	Range		Address		R/W	Default
					Max	Min	Hex	Dec		
SETA	SEEA	Level 3	SET5.3	Alarm special function setting. 0000 = 0 0001 = 1 0010 = 16 0011 = 17 0100 = 256 0101 = 257 0110 = 272 0111 = 273 1000 = 4096 1001 = 4097 1010 = 4112 1011 = 4113 1100 = 4352 1101 = 4353 1110 = 4368 1111 = 4369	4369	0	0x5F	95	R/W	0
PSL	PSL	Level 3	SET5.4	Protocol selection. 0 : TAIE 1 : RTU	1	0	0x60	96	R	1
BITS	BIT5	Level 3	SET5.4	Data format. 0 : O_81 (parity bit = odd, stop bit = 1) 1 : O_82 (parity bit = odd, stop bit = 2) 2 : E_81 (parity bit = even, stop bit = 1) 3 : E_82 (parity bit = even, stop bit = 2) 4 : N_81 (parity bit = none, stop bit = 1) 5 : N_82 (parity bit = none, stop bit = 2)	5	0	0x61	97	R	0
IDNO	IDNO	Level 3	SET5.4	Controller station.	254	0	0x62	98	R	1
BAUD	BAUD	Level 3	SET5.4	Baud rate. 0 : 24(2400) 1 : 48(4800) 2 : 96(9600) 3 : 192(19200) 4 : 384(38400) 5 : 576(57600) 6 : 1152(115200) bps	6	0	0x63	99	R	4
SVOS	SVOS	Level 3	SET6.1	SV bias.	1000	-1000	0x64	100	R/W	0
PVOS	PVOS	Level 3	SET6.2	PV bias. PV = PV + PVOS	1999	-1999	0x65	101	R/W	0
UNIT	UNIT	Level 3	SET6.3	Unit. Change this parameter USPL&LSPL will be reset 0 : °C 1 : °F 2 : U (Linear signal)	2	0	0x66	102	R/W	---
PVFT	PVFE	Level 3	SET6.4	PV digital filter The PV filter is used to eliminate noise against the measured input. Unit : second	10.00	0.01	0x67	103	R/W	2.00
PV2	PV2	Level 3	OUTY=2 & SET7.1	Use for motor valve feedback value	100.0	0.0	0x68	104	R	---
ODD	ODD	Level 3	SET7.2	Control action selection. 0 : HEAT (reverse action) 1 : COOL (direct action)	1	0	0x69	105	R/W	1
OPAD	OPAD	Level 3	SET7.3	Super SV function enable. 0 : OFF 1 : ON	1	0	0x6A	106	R/W	0
HZ	HZ	Level 3	SET7.4	Power frequency. 0 : 50HZ 1 : 60HZ	1	0	0x6B	107	R/W	1
SET1	SEEA	Level 4	---	Parameters Hide/Display	4369	0	0x6C	108	R/W	---
SET2	SEEA	Level 4	---	Parameters Hide/Display	4369	0	0x6D	109	R/W	---

## 7. Communication Parameter Address

Parameter	Display	Level	Hide/Display	Content	Range		Address		R/W	Default
					Max	Min	Hex	Dec		
SET3	SEET3	Level 4	---	Parameters Hide/Display	4369	0	0x6E	110	R/W	---
SET4	SEET4	Level 4	---	Parameters Hide/Display	4369	0	0x6F	111	R/W	---
SET5	SEET5	Level 4	---	Parameters Hide/Display	4369	0	0x70	112	R/W	---
SET6	SEET6	Level 4	---	Parameters Hide/Display	4369	0	0x71	113	R/W	---
SET7	SEET7	Level 4	---	Parameters Hide/Display	4369	0	0x72	114	R/W	---
SET8	SEET8	Level 4	---	Parameters Hide/Display	4369	0	0x73	115	R/W	---
SET9	SEET9	Level 4	---	Parameters Hide/Display	4369	0	0x74	116	R/W	---
SET0	SEET0	Level 4	---	Parameters Hide/Display	4369	0	0x75	117	R/W	---
INP2	INP2	Level 4	---	Sub input type selection. 0 : none 1 : 10~50mV / 4~20mA / 1~5V / 2~10V (remote SV use) 2 : 0~50mV / 0~20mA / 0~5V / 0~10V (remote SV use) 3 : valve feedback 4 : CT input	4	0	0x76	118	R/W	---
OUTY	OUTY	Level 4	---	Hardware drive selection. 0 : single output control 1 : dual output control 2 : valve control with feedback 3 : valve control without feedback selection 4 : single phase control	5	0	0x77	119	R/W	---
OUT%	---	---	---	Manipulated value for output.	1000	0	0x87	135	R	---
OBIT	---	---	---	Controller Information Bits. 2 <sup>0</sup> = OUT1 2 <sup>1</sup> = OUT2 2 <sup>2</sup> = AT 2 <sup>3</sup> = AL1 2 <sup>4</sup> = AL2 2 <sup>5</sup> = AL3 2 <sup>6</sup> = PRO 2 <sup>7</sup> = MAN 2 <sup>8</sup> = IN1E 2 <sup>9</sup> = ADCF 2 <sup>10</sup> = CJCE 2 <sup>11</sup> = IN2E 2 <sup>12</sup> = UUU1 2 <sup>13</sup> = NNN1 2 <sup>14</sup> = UUU2 2 <sup>15</sup> = NNN2	65535	0	0x88	136	R	---
CV	---	---	---	Sub input process value. Use for remote function or motor valve feedback value	---	---	0x89	137	R	---
PV	8250	Level 1	---	Process value.	USPL	LSPL	0x8A	138	R	---
REMO	---	---	---	Remote control program execute 0 : program execute by key 1 : program execute by key or communication	1	0	0x115	277	R/W	0

Parameter	Display	Level	Hide/ Display	Content	Range		Address		R/W	Default
					Max	Min	Hex	Dec		
INP1		Fast	---	Main input type selection Change this parameter USPL & LSPL will be reset. 0 : K1 (-50.0~600.0°C) 1 : K2 (-50~1200°C) 2 : J1 (-50.0~400.0°C) 3 : J2 (-50~400°C) 4 : R (-50~1760°C) 5 : S (-50~1760°C) 6 : B (-50~1820°C) 7 : E (-50~900°C) 8 : N (-50~1300°C) 9 : T1 (-199.9~400.0°C) 10 : T2 (-199~400°C) 11 : W (-50~2320°C) 12 : PL (-50~1200°C) 13 : L (-50~800°C) 14 : PT1 (-199.9~850.0°C) 15 : PT2 (-199~850°C) 16 : PT3 (0~850°C) 17 : AN1 18 : AN2 19 : AN3 20 : AN4	AN4	K1	0x48	72	R/W	K1
RUCY		Fast	OUTY=2 or 3	Motor valve traveling time. Time unit : second	150	5	0x5D	93	R/W	5
CYT1		Fast	OUTY=2 or 3	Motor valve action interval time. Time unit : second	10	0	0x3E	62	R/W	5
HYSM		Fast	OUTY = 2 or 3	Motor valve action main adjustment unit : percentage	5.0	0.0	0x44	68	R/W	1.0
HYS1		Fast	OUTY = 2 or 3	Motor valve action sub adjustment unit : percentage	HYSM	0.0	0x3F	63	R/W	0.5
RH.TC		Fast	---	Dehumidification temperature If PV less than RHTC manipulated value = RHPO	2000	0	0x12F	303	R/W	1250
RH.PO		Fast	---	Dehumidification manipulated value 0 : OFF disable dehumidification function Other values : 0.1~100.0 manipulated value	100.0	OFF	0x130	304	R/W	OFF
RH.TM		Fast	---	Dehumidification time time format : minute.second 00.00~99.58 : execute dehumidification time	99.59	0.00	0x131	305	R/W	15.00
OPFT		Fast	---	Output filter Unit : second	10.00	0.10	0x12D	301	R/W	2.00
PV2		Fast	OUTY=2 & SET7.1	Use for motor valve feedback value	100.0	0.0	0x68	104	R	---
MOLH		Fast	---	High limit setting of manipulated value for main output	100.0	0.0	0x01	1	R/W	100.0
MOLL		Fast	---	low limit setting of manipulated value for main output	100.0	0.0	0x12E	302	R/W	0.0
PMAC		Fast	SET8.4	Automatic valve position adjustment 0 : OFF stop automatic adjust 1 : ON start automatic adjust 2 : E_PB Valve position determined by external button	2	0	---	---	R	0
PSL		Fast	SET5.4	Protocol selection. 0 : TAIE 1 : RTU	1	0	0x60	96	R	1
BITS		Fast	SET5.4	Data format. 0 : O_81 (parity bit = odd, stop bit = 1) 1 : O_82 (parity bit = odd, stop bit = 2) 2 : E_81 (parity bit = even, stop bit = 1) 3 : E_82 (parity bit = even, stop bit = 2) 4 : N_81 (parity bit = none, stop bit = 1) 5 : N_82 (parity bit = none, stop bit = 2)	5	0	0x61	97	R	0

7. Communication Parameter Address

Parameter	Display	Level	Hide/Display	Content	Range		Address		R/W	Default
					Max	Min	Hex	Dec		
IDNO	1270	Fast	SET5.4	Controller station.	254	0	0x62	98	R	1
BAUD	BAUD	Fast	SET5.4	Baud rate. 0 : 24(2400) 1 : 48(4800) 2 : 96(9600) 3 : 192(19200) 4 : 384(38400) 5 : 576(57600) 6 : 1152(115200) bps	6	0	0x63	99	R	4
W_MD	0000	Fast	SET5.4	EEPROM protection 0 : OFF communication write command only write to CPU RAM 1 : ON communication write command write to CPU RAM and EEPROM	ON	OFF	0x119	281	R	ON
TRCL	EFCL	Fast	SET2.2	Main input TC/RTD zero calibration	9999	0	0x132	306	R/W	0
TRCH	EFCH	Fast	SET2.2	Main input TC/RTD span calibration (hex display)	7FFF	0	0x133	307	R/W	5FFF
HBOP	HbOP	Fast	INP2=4 & ALD1=9	Heater break output exceeds percentage setting value.	100.0	0.0	0x12C	300	R/W	90.0
PVOH	PVOH	Fast	SET6.2	PV bias(for span) PV = PV x (PVOH / 5000) + PVOS	9999	0	0x134	308	R/W	5000
PVST	PVSE	Fast	SET8.3	Program execute start address 0 : FULT (execute from current PV, but use segment 1 fully time) 1 : CUTT (execute from current PV, cut time)	CUTT	FULT	0x11E	286	R/W	FULT
MV.SF	00SF	Fast	INP1=AN1~AN4	Analog input special function selection 0 : NONE (special function OFF) 1 : SQUA (analog input square) 2 : ROOT (analog input square root) 3 : REVE (analog input reverse) 4 : SQ.RE (analog input square reverse) 5 : RO.RE (analog input square root reverse)	5	0	0x12B	299	R/W	NONE
LAP1	---	---	---	message indicator bit 2 <sup>0</sup> = OUT1 2 <sup>1</sup> = OUT2 2 <sup>2</sup> = AT 2 <sup>3</sup> = AL1 2 <sup>4</sup> = AL2 2 <sup>5</sup> = AL3 2 <sup>6</sup> = PRO 2 <sup>7</sup> = MAN 2 <sup>8</sup> = Program_Run 2 <sup>9</sup> = Program_End 2 <sup>10</sup> = Program_Wait 2 <sup>11</sup> = r 2 <sup>12</sup> = Program_Halt 2 <sup>13</sup> = r 2 <sup>14</sup> = r 2 <sup>15</sup> = r ※ r : reserve	65535	0	0x408	1032	R	---
PKE1	---	---	---	Program remote control. Use this parameter please make sure REMO=1. 2 <sup>0</sup> = r 2 <sup>1</sup> = r 2 <sup>2</sup> = r 2 <sup>3</sup> = r 2 <sup>4</sup> = r 2 <sup>5</sup> = r 2 <sup>6</sup> = r 2 <sup>7</sup> = r 2 <sup>8</sup> = 256 (RUN) 2 <sup>9</sup> = 512 (HALT) 2 <sup>10</sup> = 1024 (JUMP) 2 <sup>11</sup> = 2048 (RESET) 2 <sup>12</sup> = r 2 <sup>13</sup> = r 2 <sup>14</sup> = r 2 <sup>15</sup> = r ※ r :reserve	65535	0	0x409	1033	W	---
1MMV	---	---	---	Manipulated value for output.1	1000	0	0x411	1041	R	---
1SMV	---	---	---	Manipulated value for output.2	1000	0	0x412	1042	R	---

## 7.2 Program Parameters Address

Pattern	Segment	Parameter	Address	
			Hex	Dec
PTN =1	SEG = 1	SV_1	0x09	9
		TM_1	0x0A	10
		OUT1	0x0B	11
	SEG = 2	SV_2	0x0C	12
		TM_2	0x0D	13
		OUT2	0x0E	14
	SEG = 3	SV_3	0x0F	15
		TM_3	0x010	16
		OUT3	0x011	17
	SEG = 4	SV_4	0x012	18
		TM_4	0x013	19
		OUT4	0x014	20
	SEG = 5	SV_5	0x015	21
		TM_5	0x016	22
		OUT5	0x017	23
	SEG = 6	SV_6	0x018	24
		TM_6	0x019	25
		OUT6	0x01A	26
	SEG = 7	SV_7	0x01B	27
		TM_7	0x01C	28
		OUT7	0x01D	29
	SEG = 8	SV_8	0x01E	30
		TM_8	0x01F	31
		OUT8	0x020	32

Pattern	Segment	Parameter	Address	
			Hex	Dec
PTN =2	SEG = 1	SV_1	0x021	33
		TM_1	0x022	34
		OUT1	0x023	35
	SEG = 2	SV_2	0x024	36
		TM_2	0x025	37
		OUT2	0x026	38
	SEG = 3	SV_3	0x027	39
		TM_3	0x028	40
		OUT3	0x029	41
	SEG = 4	SV_4	0x02A	42
		TM_4	0x02B	43
		OUT4	0x02C	44
	SEG = 5	SV_5	0x02D	45
		TM_5	0x02E	46
		OUT5	0x02F	47
	SEG = 6	SV_6	0x030	48
		TM_6	0x031	49
		OUT6	0x032	50
	SEG = 7	SV_7	0x033	51
		TM_7	0x034	52
		OUT7	0x035	53
	SEG = 8	SV_8	0x036	54
		TM_8	0x037	55
		OUT8	0x038	56

Pattern	Segment	Parameter	Address	
			Hex	Dec
PTN =3	SEG = 1	SV_1	0x01C3	451
		TM_1	0x01C5	453
		OUT1	0x01C6	454
	SEG = 2	SV_2	0x01C7	455
		TM_2	0x01C9	457
		OUT2	0x01CA	458
	SEG = 3	SV_3	0x01CB	459
		TM_3	0x01CD	461
		OUT3	0x01CE	462
	SEG = 4	SV_4	0x01CF	463
		TM_4	0x01D1	465
		OUT4	0x01D2	466
	SEG = 5	SV_5	0x01D3	467
		TM_5	0x01D5	469
		OUT5	0x01D6	470
	SEG = 6	SV_6	0x01D7	471
		TM_6	0x01D9	473
		OUT6	0x01DA	474
	SEG = 7	SV_7	0x01DB	475
		TM_7	0x01DD	477
		OUT7	0x01DE	478
	SEG = 8	SV_8	0x01DF	479
		TM_8	0x01E1	481
		OUT8	0x01E2	482

Pattern	Segment	Parameter	Address	
			Hex	Dec
PTN =4	SEG = 1	SV_1	0x01E3	483
		TM_1	0x01E5	485
		OUT1	0x01E6	486
	SEG = 2	SV_2	0x01E7	487
		TM_2	0x01E9	489
		OUT2	0x01EA	490
	SEG = 3	SV_3	0x01EB	491
		TM_3	0x01ED	493
		OUT3	0x01EE	494
	SEG = 4	SV_4	0x01EF	495
		TM_4	0x01F1	497
		OUT4	0x01F2	498
	SEG = 5	SV_5	0x01F3	499
		TM_5	0x01F5	501
		OUT5	0x01F6	502
	SEG = 6	SV_6	0x01F7	503
		TM_6	0x01F9	505
		OUT6	0x01FA	506
	SEG = 7	SV_7	0x01FB	507
		TM_7	0x01FD	509
		OUT7	0x01FE	510
	SEG = 8	SV_8	0x01FF	511
		TM_8	0x0201	513
		OUT8	0x0202	514

7. Communication Parameter Address

Pattern	Segment	Parameter	Address	
			Hex	Dec
PTN =5	SEG = 1	SV_1	0x0203	515
		TM_1	0x0205	517
		OUT1	0x0206	518
	SEG = 2	SV_2	0x0207	519
		TM_2	0x0209	521
		OUT2	0x020A	522
	SEG = 3	SV_3	0x020B	523
		TM_3	0x020D	525
		OUT3	0x020E	526
	SEG = 4	SV_4	0x020F	527
		TM_4	0x0211	529
		OUT4	0x0212	530
	SEG = 5	SV_5	0x0213	531
		TM_5	0x0215	533
		OUT5	0x0216	534
	SEG = 6	SV_6	0x0217	535
		TM_6	0x0219	537
		OUT6	0x021A	538
	SEG = 7	SV_7	0x021B	539
		TM_7	0x021D	541
		OUT7	0x021E	542
	SEG = 8	SV_8	0x021F	543
		TM_8	0x0221	545
		OUT8	0x0222	546

Pattern	Segment	Parameter	Address	
			Hex	Dec
PTN =6	SEG = 1	SV_1	0x0223	547
		TM_1	0x0225	549
		OUT1	0x0226	550
	SEG = 2	SV_2	0x0227	551
		TM_2	0x0229	553
		OUT2	0x022A	554
	SEG = 3	SV_3	0x022B	555
		TM_3	0x022D	557
		OUT3	0x022E	558
	SEG = 4	SV_4	0x022F	559
		TM_4	0x0231	561
		OUT4	0x0232	562
	SEG = 5	SV_5	0x0233	563
		TM_5	0x0235	565
		OUT5	0x0236	566
	SEG = 6	SV_6	0x0237	567
		TM_6	0x0239	569
		OUT6	0x023A	570
	SEG = 7	SV_7	0x023B	571
		TM_7	0x023D	573
		OUT7	0x023E	574
	SEG = 8	SV_8	0x023F	575
		TM_8	0x0241	577
		OUT8	0x0242	578

Pattern	Segment	Parameter	Address	
			Hex	Dec
PTN =7	SEG = 1	SV_1	0x0243	579
		TM_1	0x0245	581
		OUT1	0x0246	582
	SEG = 2	SV_2	0x0247	583
		TM_2	0x0249	585
		OUT2	0x024A	586
	SEG = 3	SV_3	0x024B	587
		TM_3	0x024D	589
		OUT3	0x024E	590
	SEG = 4	SV_4	0x024F	591
		TM_4	0x0251	593
		OUT4	0x0252	594
	SEG = 5	SV_5	0x0253	595
		TM_5	0x0255	597
		OUT5	0x0256	598
	SEG = 6	SV_6	0x0257	599
		TM_6	0x0259	601
		OUT6	0x025A	602
	SEG = 7	SV_7	0x025B	603
		TM_7	0x025D	605
		OUT7	0x025E	606
	SEG = 8	SV_8	0x025F	607
		TM_8	0x0261	609
		OUT8	0x0262	610

Pattern	Segment	Parameter	Address	
			Hex	Dec
PTN =8	SEG = 1	SV_1	0x0263	611
		TM_1	0x0265	613
		OUT1	0x0266	614
	SEG = 2	SV_2	0x0267	615
		TM_2	0x0269	617
		OUT2	0x026A	618
	SEG = 3	SV_3	0x026B	619
		TM_3	0x026D	621
		OUT3	0x026E	622
	SEG = 4	SV_4	0x026F	623
		TM_4	0x0271	625
		OUT4	0x0272	626
	SEG = 5	SV_5	0x0273	627
		TM_5	0x0275	629
		OUT5	0x0276	630
	SEG = 6	SV_6	0x0277	631
		TM_6	0x0279	633
		OUT6	0x027A	634
	SEG = 7	SV_7	0x027B	635
		TM_7	0x027D	637
		OUT7	0x027E	638
	SEG = 8	SV_8	0x027F	639
		TM_8	0x0281	641
		OUT8	0x0282	642



Pattern	Segment	Parameter	Address	
			Hex	Dec
PTN =9	SEG = 1	SV_1	0x0283	643
		TM_1	0x0285	645
		OUT1	0x0286	646
	SEG = 2	SV_2	0x0287	647
		TM_2	0x0289	649
		OUT2	0x028A	650
	SEG = 3	SV_3	0x028B	651
		TM_3	0x028D	653
		OUT3	0x028E	654
	SEG = 4	SV_4	0x028F	655
		TM_4	0x0291	657
		OUT4	0x0292	658
	SEG = 5	SV_5	0x0293	659
		TM_5	0x0295	661
		OUT5	0x0296	662
	SEG = 6	SV_6	0x0297	663
		TM_6	0x0299	665
		OUT6	0x029A	666
	SEG = 7	SV_7	0x029B	667
		TM_7	0x029D	669
		OUT7	0x029E	670
	SEG = 8	SV_8	0x029F	671
		TM_8	0x02A1	673
		OUT8	0x02A2	674

Pattern	Segment	Parameter	Address	
			Hex	Dec
PTN =10	SEG = 1	SV_1	0x02A3	675
		TM_1	0x02A5	677
		OUT1	0x02A6	678
	SEG = 2	SV_2	0x02A7	679
		TM_2	0x02A9	681
		OUT2	0x02AA	682
	SEG = 3	SV_3	0x02AB	683
		TM_3	0x02AD	685
		OUT3	0x02AE	686
	SEG = 4	SV_4	0x02AF	687
		TM_4	0x02B1	689
		OUT4	0x02B2	690
	SEG = 5	SV_5	0x02B3	691
		TM_5	0x02B5	693
		OUT5	0x02B6	694
	SEG = 6	SV_6	0x02B7	695
		TM_6	0x02B9	697
		OUT6	0x02BA	698
	SEG = 7	SV_7	0x02BB	699
		TM_7	0x02BD	701
		OUT7	0x02BE	702
	SEG = 8	SV_8	0x02BF	703
		TM_8	0x02C1	705
		OUT8	0x02C2	706

Pattern	Segment	Parameter	Address	
			Hex	Dec
PTN =11	SEG = 1	SV_1	0x02C3	707
		TM_1	0x02C5	709
		OUT1	0x02C6	710
	SEG = 2	SV_2	0x02C7	711
		TM_2	0x02C9	713
		OUT2	0x02CA	714
	SEG = 3	SV_3	0x02CB	715
		TM_3	0x02CD	717
		OUT3	0x02CE	718
	SEG = 4	SV_4	0x02CF	719
		TM_4	0x02D1	721
		OUT4	0x02D2	722
	SEG = 5	SV_5	0x02D3	723
		TM_5	0x02D5	725
		OUT5	0x02D6	726
	SEG = 6	SV_6	0x02D7	727
		TM_6	0x02D9	729
		OUT6	0x02DA	730
	SEG = 7	SV_7	0x02DB	731
		TM_7	0x02DD	733
		OUT7	0x02DE	734
	SEG = 8	SV_8	0x02DF	735
		TM_8	0x02E1	737
		OUT8	0x02E2	738

Pattern	Segment	Parameter	Address	
			Hex	Dec
PTN =12	SEG = 1	SV_1	0x02E3	739
		TM_1	0x02E5	741
		OUT1	0x02E6	742
	SEG = 2	SV_2	0x02E7	743
		TM_2	0x02E9	745
		OUT2	0x02EA	746
	SEG = 3	SV_3	0x02EB	747
		TM_3	0x02ED	749
		OUT3	0x02EE	750
	SEG = 4	SV_4	0x02EF	751
		TM_4	0x02F1	753
		OUT4	0x02F2	754
	SEG = 5	SV_5	0x02F3	755
		TM_5	0x02F5	757
		OUT5	0x02F6	758
	SEG = 6	SV_6	0x02F7	759
		TM_6	0x02F9	761
		OUT6	0x02FA	762
	SEG = 7	SV_7	0x02FB	763
		TM_7	0x02FD	765
		OUT7	0x02FE	766
	SEG = 8	SV_8	0x02FF	767
		TM_8	0x0301	769
		OUT8	0x0302	770

7. Communication Parameter Address

Pattern	Segment	Parameter	Address	
			Hex	Dec
PTN =13	SEG = 1	SV_1	0x0303	771
		TM_1	0x0305	773
		OUT1	0x0306	774
	SEG = 2	SV_2	0x0307	775
		TM_2	0x0309	777
		OUT2	0x030A	778
	SEG = 3	SV_3	0x030B	779
		TM_3	0x030D	781
		OUT3	0x030E	782
	SEG = 4	SV_4	0x030F	783
		TM_4	0x0311	785
		OUT4	0x0312	786
	SEG = 5	SV_5	0x0313	787
		TM_5	0x0315	789
		OUT5	0x0316	790
	SEG = 6	SV_6	0x0317	791
		TM_6	0x0319	793
		OUT6	0x031A	794
	SEG = 7	SV_7	0x031B	795
		TM_7	0x031D	797
		OUT7	0x031E	798
	SEG = 8	SV_8	0x031F	799
		TM_8	0x0321	801
		OUT8	0x0322	802

Pattern	Segment	Parameter	Pattern	
			Hex	Dec
PTN =14	SEG = 1	SV_1	0x0323	803
		TM_1	0x0325	805
		OUT1	0x0326	806
	SEG = 2	SV_2	0x0327	807
		TM_2	0x0329	809
		OUT2	0x032A	810
	SEG = 3	SV_3	0x032B	811
		TM_3	0x032D	813
		OUT3	0x032E	814
	SEG = 4	SV_4	0x032F	815
		TM_4	0x0331	817
		OUT4	0x0332	818
	SEG = 5	SV_5	0x0333	819
		TM_5	0x0335	821
		OUT5	0x0336	822
	SEG = 6	SV_6	0x0337	823
		TM_6	0x0339	825
		OUT6	0x033A	826
	SEG = 7	SV_7	0x033B	827
		TM_7	0x033D	829
		OUT7	0x033E	830
	SEG = 8	SV_8	0x033F	831
		TM_8	0x0341	833
		OUT8	0x0342	834

Pattern	Segment	Parameter	Address	
			Hex	Dec
PTN =15	SEG = 1	SV_1	0x0343	835
		TM_1	0x0345	837
		OUT1	0x0346	838
	SEG = 2	SV_2	0x0347	839
		TM_2	0x0349	841
		OUT2	0x034A	842
	SEG = 3	SV_3	0x034B	843
		TM_3	0x034D	845
		OUT3	0x034E	846
	SEG = 4	SV_4	0x034F	847
		TM_4	0x0351	849
		OUT4	0x0352	850
	SEG = 5	SV_5	0x0353	851
		TM_5	0x0355	853
		OUT5	0x0356	854
	SEG = 6	SV_6	0x0357	855
		TM_6	0x0359	857
		OUT6	0x035A	858
	SEG = 7	SV_7	0x035B	859
		TM_7	0x035D	861
		OUT7	0x035E	862
	SEG = 8	SV_8	0x035F	863
		TM_8	0x0361	865
		OUT8	0x0362	866

Pattern	Segment	Parameter	Address	
			Hex	Dec
PTN =16	SEG = 1	SV_1	0x0363	867
		TM_1	0x0365	869
		OUT1	0x0366	870
	SEG = 2	SV_2	0x0367	871
		TM_2	0x0369	873
		OUT2	0x036A	874
	SEG = 3	SV_3	0x036B	875
		TM_3	0x036D	877
		OUT3	0x036E	878
	SEG = 4	SV_4	0x036F	879
		TM_4	0x0371	881
		OUT4	0x0372	882
	SEG = 5	SV_5	0x0373	883
		TM_5	0x0375	885
		OUT5	0x0376	886
	SEG = 6	SV_6	0x0377	887
		TM_6	0x0379	889
		OUT6	0x037A	890
	SEG = 7	SV_7	0x037B	891
		TM_7	0x037D	893
		OUT7	0x037E	894
	SEG = 8	SV_8	0x037F	895
		TM_8	0x0381	897
		OUT8	0x0382	898

Pattern	Segment	Parameter	Address	
			Hex	Dec
PTN =17	SEG = 1	SV_1	0x0383	899
		TM_1	0x0385	901
		OUT1	0x0386	902
	SEG = 2	SV_2	0x0387	903
		TM_2	0x0389	905
		OUT2	0x038A	906
	SEG = 3	SV_3	0x038B	907
		TM_3	0x038D	909
		OUT3	0x038E	910
	SEG = 4	SV_4	0x038F	911
		TM_4	0x0391	913
		OUT4	0x0392	914
	SEG = 5	SV_5	0x0393	915
		TM_5	0x0395	917
		OUT5	0x0396	918
	SEG = 6	SV_6	0x0397	919
		TM_6	0x0399	921
		OUT6	0x039A	922
	SEG = 7	SV_7	0x039B	923
		TM_7	0x039D	925
		OUT7	0x039E	926
	SEG = 8	SV_8	0x039F	927
		TM_8	0x03A1	929
		OUT8	0x03A2	930

Pattern	Segment	Parameter	Address	
			Hex	Dec
PTN =18	SEG = 1	SV_1	0x03A3	931
		TM_1	0x03A5	933
		OUT1	0x03A6	934
	SEG = 2	SV_2	0x03A7	935
		TM_2	0x03A9	937
		OUT2	0x03AA	938
	SEG = 3	SV_3	0x03AB	939
		TM_3	0x03AD	941
		OUT3	0x03AE	942
	SEG = 4	SV_4	0x03AF	943
		TM_4	0x03B1	945
		OUT4	0x03B2	946
	SEG = 5	SV_5	0x03B3	947
		TM_5	0x03B5	949
		OUT5	0x03B6	950
	SEG = 6	SV_6	0x03B7	951
		TM_6	0x03B9	953
		OUT6	0x03BA	954
	SEG = 7	SV_7	0x03BB	955
		TM_7	0x03BD	957
		OUT7	0x03BE	958
	SEG = 8	SV_8	0x03BF	959
		TM_8	0x03C1	961
		OUT8	0x03C2	962

### 7.3 Piece Linear Compensation Parameters Address

Linearize number	Parameter	Address	
		Hex	Dec
MLNB = 1	COMP	0x15B	347
	OFFS	0x165	357
MLNB = 2	COMP	0x15C	348
	OFFS	0x166	358
MLNB = 3	COMP	0x15D	349
	OFFS	0x167	359
MLNB = 4	COMP	0x15E	350
	OFFS	0x168	360
MLNB = 5	COMP	0x15F	351
	OFFS	0x169	361
MLNB = 6	COMP	0x160	352
	OFFS	0x16A	362
MLNB = 7	COMP	0x161	353
	OFFS	0x16B	363
MLNB = 8	COMP	0x162	354
	OFFS	0x16C	364
MLNB = 9	COMP	0x163	355
	OFFS	0x16D	365
MLNB = 10	COMP	0x164	356
	OFFS	0x16E	366













台灣儀控股份有限公司  
TAIWAN INSTRUMENT & CONTROL CO., LTD

Phone: +886-2-8226-1867  
Fax: +886-2-8226-1834

E-mail: [contact@fa-taie.com.tw](mailto:contact@fa-taie.com.tw)  
URL: <http://www.fa-taie.com.tw>



2022.12.20