

# FE

Rail Type  
Controller

FE250  
FE251  
FE300

Digital Process Controller



**TAIE**

台灣儀控股份有限公司  
TAIWAN INSTRUMENT & CONTROL CO., LTD

Classic evolution

# High-Performance Process Control

High Accuracy  $\pm 0.1\%$

Sampling Time 50ms

Speed upper to 115200 bps

DIN rail mounting

Precise control

High Reliability



## Excellent Anti-Interference Ability



Passing the highest level of EMC verification in CE certification. It can resist electromagnetic interference in heavy noise environment.

## Ultra Low Temperature Drift



Any operating conditions have been considered in the design, even if in temperature variety ambience, it also not affects PV and control performance.

## High Speed Sampling And High Accuracy



Input can perform 50ms high-speed sampling, enabling stable control and response. Built-in 18-bit high resolution ADC circuit provides up to 0.1% accuracy.

## Certification And Universal Voltage



All models get CE approval. operate on any voltage from AC 85~265V at 50/60 Hz, DC 24V is also available.

## DIN Rail Mounting



DIN-rail installation, thin type of body can save lots of space also easy to use in multi-point control and communication.

## Parameter Lock Function



All parameters are separated in five operation levels (Level1~Level5). Each parameter can be hidden or locked to prevent users unauthorized changes.

## Status Indicator Lamp

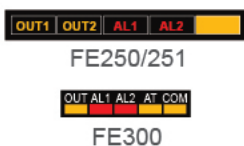

Real time monitor the status of output (OUT1/OUT2), alarm(AL1/AL2), communication(COM) and auto-tuning(AT).

## Register Mapping



Compatible with FY series controller, parameter address can be switched by software, without changing original HMI or PLC program.

# Function Block Diagram

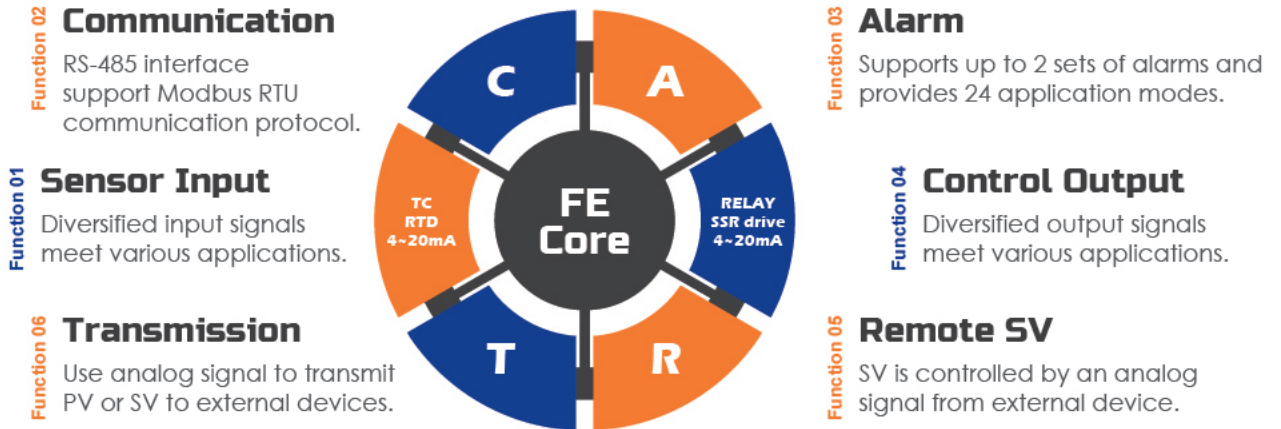

## Features

### Various I/O Types

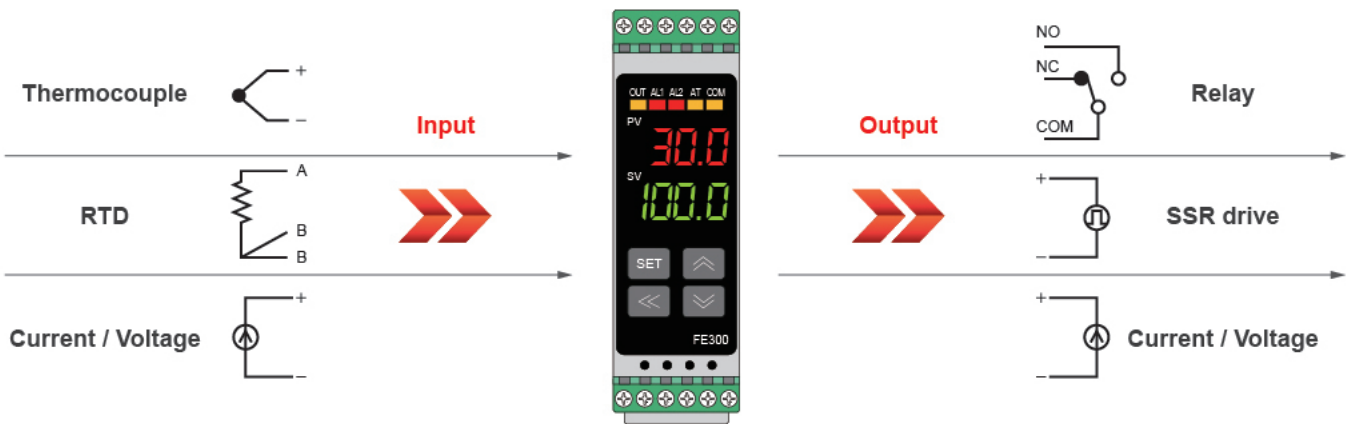

### Excellent Control Performance

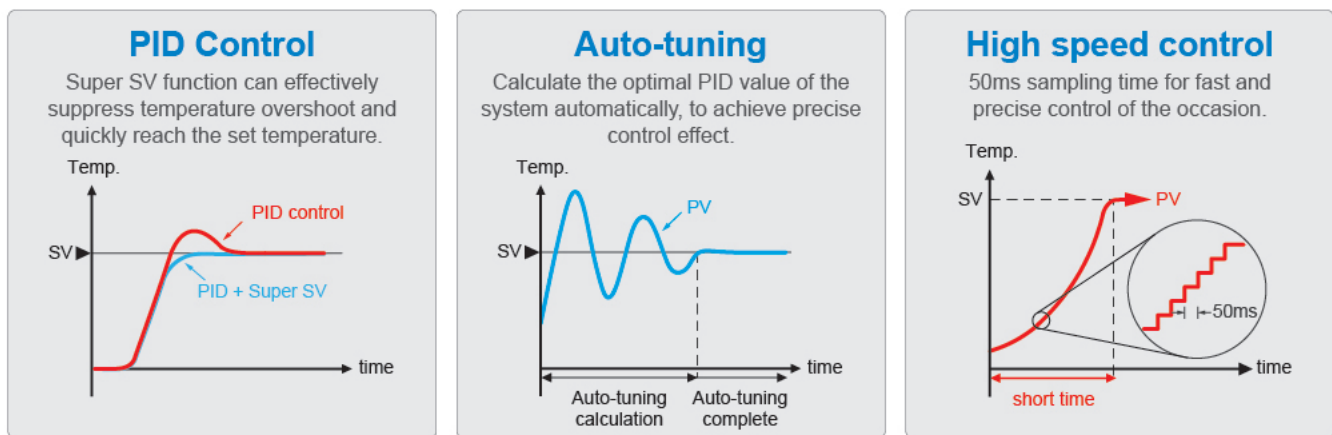

### Fast and Stable RS-485 Communication

Compatible with Modbus RTU communication protocol to quickly establish links with HMI, PLC or SCADA software.

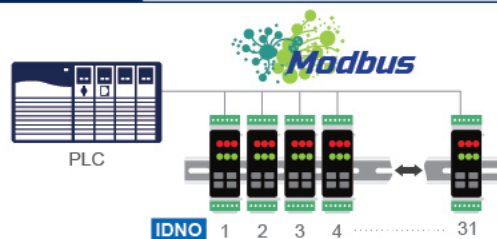

# Features

## Heating and Cooling Control

Using two outputs of the controller, as long as a controller can control the heating / cooling equipment.

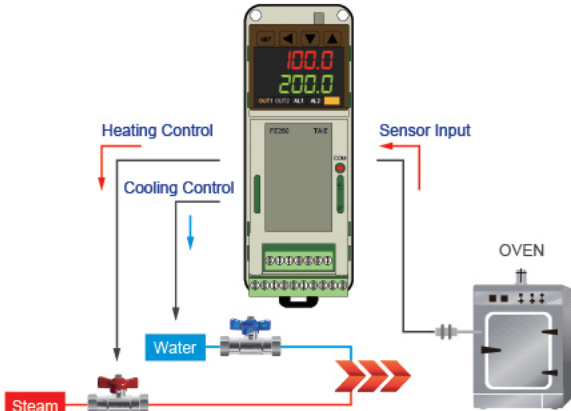

## Heater Break Alarm

With a CT (current transformer) to monitor the heater current in real time, when the current value is abnormally reduced an alarm signal can be output to notify the user.

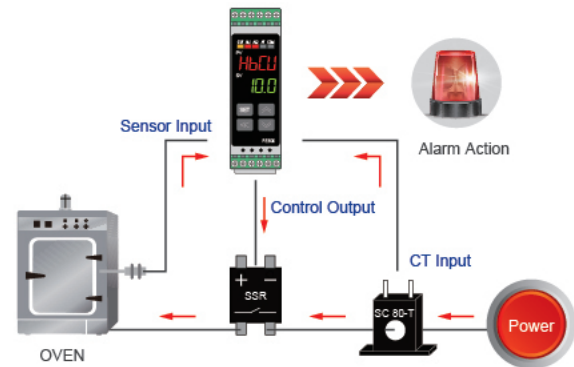

## Transmission

Transfer parameter digital values as analog signals to external devices.

signals: 0~20mA    4~20mA    0~5V  
1~5V    0~10V.....

parameters: SV1    PV1    MV1.....



## Remote SV

SV is controlled by an analog signal from an external device.

signals: 0~20mA    4~20mA    0~5V  
1~5V    0~10V.....

parameters: SV

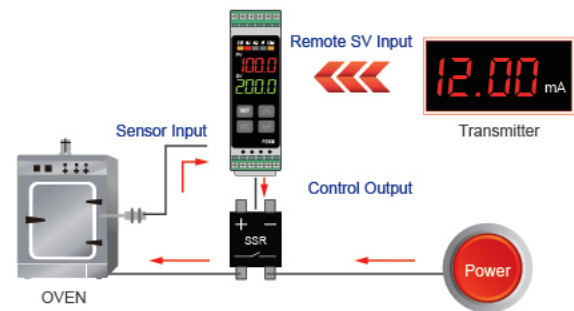

## Bumpless Transfer

When the automatic mode is changed to manual mode, the current manipulated value will be loaded, make sure the system not be impacted by sudden changes.

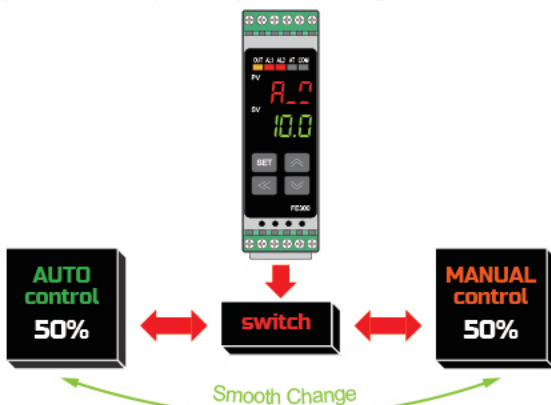

## MV% Maintain and Limit

In the high manipulated value can be limited, to protect the system avoid overheating.

In the low manipulated value can be keep, to maintain the system running.

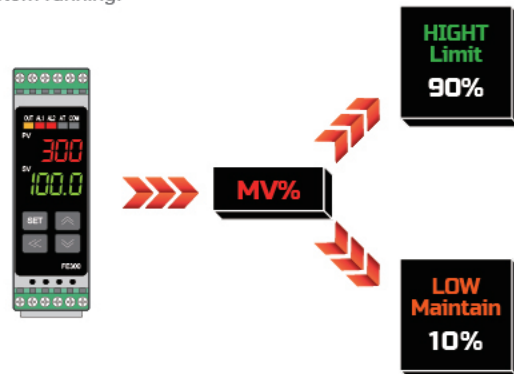

# Appearance

## Parts Description

FE250 FE251

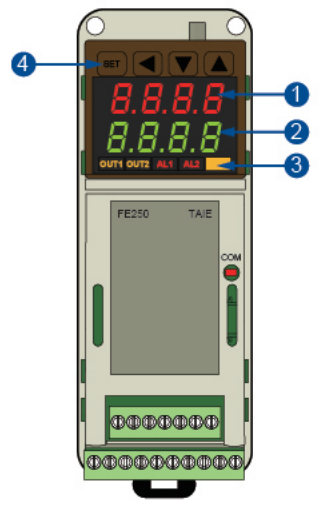

1	PV	Indicates PV (measured value) and character information such as parameter codes and error codes (Red)	
2	SV	Indicates SV (target set value) and parameter Values (Green)	
3	LED	OUT1	Lamp lit when OUT1 is activated (Orange)
		OUT2	Lamp lit when OUT2 is activated (Orange)
		AL1	Lamp lit when Alarm 1 is activated (Red)
		AL2	Lamp lit when Alarm 2 is activated (Red)
		□	Lamp lit when Auto-tuning is activated (Orange)
		COM	Lights when controller response data (Green)
4	Keypad	SET SET	For parameter call-up and set value registration
		◀ SHIFT	Shift digits when changing settings
		▼ DOWN	Decrease numerals
		▲ UP	Increase numerals

FE300

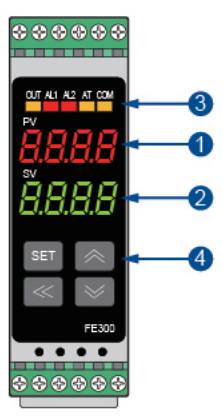





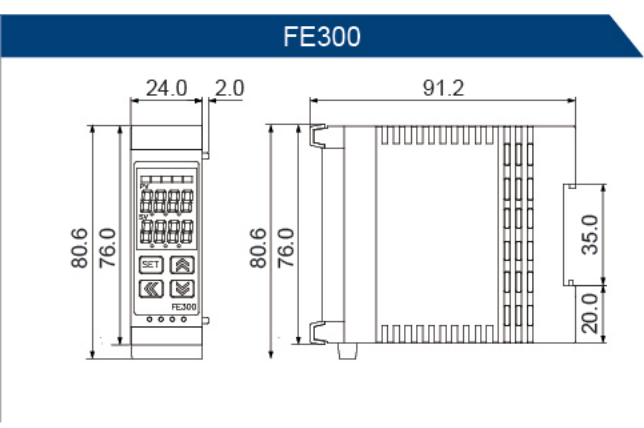
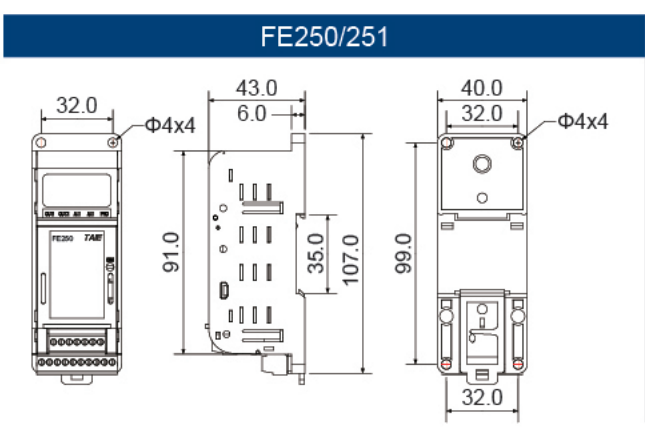





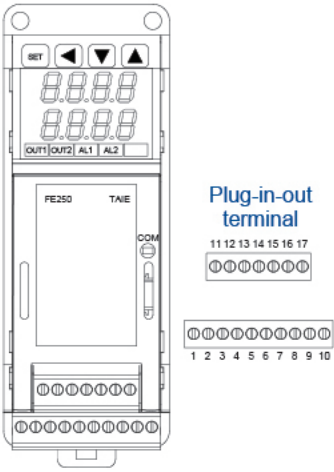

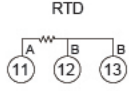



1	PV	Indicating PV (measured value) and character information such as parameter codes or error codes (Red)	
2	SV	Indicating SV (target set value) or parameter values(Green)	
3	LED	OUT1	Lamp lit when OUT1 is activated (Orange)
		AL1	Lamp lit when Alarm 1 is activated (Red)
		AL2	Lamp lit when Alarm 2 is activated (Red)
		AT	Lamp lit when Auto-tuning is activated (Orange)
		COM	Lights when controller response data (Orange)
4	Keypad	SET SET	For parameter call-up and set value registration
		◀◀ SHIFT	Shift digits when changing settings
		▼ DOWN	Decrease numerals
		▲ UP	Increase numerals

## External And Dimensions











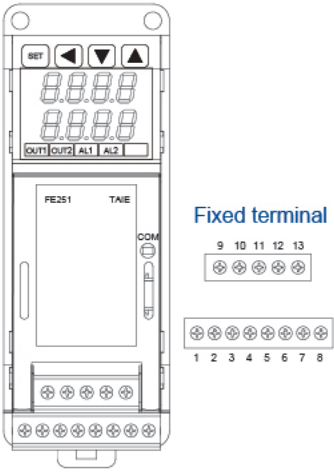

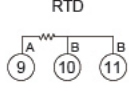





# Terminal Arrangement











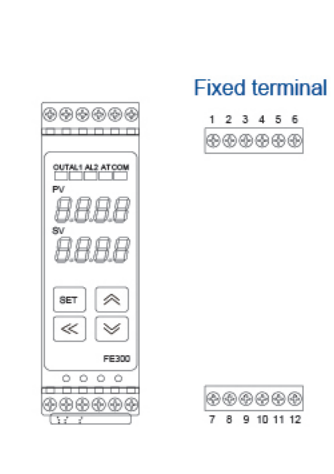





## FE250

 <p><b>Plug-in-out terminal</b> 11 12 13 14 15 16 17</p> <p>1 2 3 4 5 6 7 8 9 10</p>	Input	<p>TC / mV</p>  <p>RTD</p>  <p>mA / V</p> 	Power	<p>AC 85~265V</p>  <p>DC 24V</p> 
	Transmission	<p>mA / V</p> 	Alarm-1 Alarm-2	<p>AL1</p>  <p>AL2</p> 
	Remote SV/ CT Input	<p>mA / V</p> 	Output-2	<p>Relay</p>  <p>SSR</p>  <p>mA / V</p> 
	Communication	<p>RS-485</p> <p>T/R (B-) T/R (A+)</p> 	Output-1	<p>Relay</p>  <p>SSR</p>  <p>mA / V</p> 

## FE251

 <p><b>Fixed terminal</b> 9 10 11 12 13</p> <p>1 2 3 4 5 6 7 8</p>	Input	<p>TC / mV</p>  <p>RTD</p>  <p>mA / V</p> 	Power	<p>AC 85~265V</p>  <p>DC 24V</p> 
	Transmission	<p>mA / V</p> 	Alarm-1 Alarm-2	<p>AL1</p>  <p>AL2</p> 
	Remote SV/ CT Input	<p>mA / V</p> 	Output-2	<p>Relay</p>  <p>SSR</p>  <p>mA / V</p> 
	Communication	<p>RS-485</p> <p>T/R (B-) T/R (A+)</p> 	Output-1	<p>Relay</p>  <p>SSR</p>  <p>mA / V</p> 

## FE300

 <p><b>Fixed terminal</b> 1 2 3 4 5 6</p> <p>7 8 9 10 11 12</p>	Power	<p>AC 85~265V</p>  <p>DC 24V</p> 	Remote SV/ CT Input	<p>mA / V</p> 
	Output	<p>Relay</p>  <p>SSR</p>  <p>mA / V</p> 	Communication	<p>RS-485</p> <p>T/R (B-) T/R (A+)</p>  <p>RS-485 (No Alarm)</p> <p>T/R (A+) T/R (B-)</p> 
	Transmission	<p>mA / V</p>  <p>mA / V (No Alarm)</p>  <p>mA / V (No Output)</p> 	Input	<p>TC / mV</p>  <p>RTD</p> 
	Alarm-1 Alarm-2	<p>AL1</p>  <p>AL2</p> 	Input	<p>mA / V</p> 

# Specifications

Model		FE300	FE251	FE250
Terminal		Fixed terminal		Plug-in-out terminal
Supply Voltage		AC 85 ~ 265V, DC 24V (Optional Functions)		
Power Frequency		50/60 Hz		
Power Consumption		Approximately 6VA		
Memory		Non-Volatile Memory EEPROM		
Sensor Input ※ Please refer to Input Range Table		Accuracy : 0.1%		
		Sample time : 50ms		
		Thermocouple : (K, J, R, S, B, E, N, T, W, PLII, L)		
		RTD: PT100		
		DC Linear Analog Input: 0~20mA, 4~20mA 0~1V, 0~5V, 0~10V, 0~2V, 1~5V, 2~10V 0~25mV, 0~50mV, 0~70mV		
Output	OUT1 Relay	1a		1c
		1a SPST-NO, 250 VAC, 5A (resistive load), electrical life: 100,000 operations 1c SPDT-NO, 250 VAC, 5A (resistive load), electrical life: 50,000 operations SPDT-NC, 250 VAC, 2A (resistive load), electrical life: 20,000 operations		
	OUT2 Relay	-		1a
		SPST-NO, 250 VAC, 5A (resistive load), electrical life: 100,000 operations		
SSR Drive	ON: 24 V OFF: 0V max. load current: 20mA, with short circuit protection circuit			
linear	4~20mA, 0~20mA, 0~5V, 0~10V, 1~5V, 2~10V			
Control Method		ON-OFF or P, PI, PID control		
Alarm	Alarm 1	1a		1c
		1a SPST-NO, 250 VAC, 5A (resistive load), electrical life: 100,000 operations 1c SPDT-NO, 250 VAC, 5A (resistive load), electrical life: 50,000 operations SPDT-NC, 250 VAC, 2A (resistive load), electrical life: 20,000 operations		
	Alarm 2	1a SPST-NO, 250 VAC, 5A (resistive load), electrical life: 100,000 operations		
TRS	Re-transmitted Signal	4~20mA, 0~20mA, 0~5V, 0~10V, 1~5V, 2~10V		
	Source of Re-transmission	SV1, PV1, MV1, SV1R, PV1R, MV1R, SV2, PV2, MV2, SV2R, PV2R, MV2R		
	Accuracy	0.1%		
	Resolution	14 bit		
Remote SV	Signal	4~20mA, 0~20mA, 0~5V, 0~10V, 1~5V, 2~10V		
	Resolution	18 bit		
	Controlled by	SV		
Communication	Interface	RS-485 Half duplex Communication MAX. 31 units, MAX. distance 1200 meters		
	Protocol	Modbus RTU, TAIE		
	Parity bit	NONE, ODD, EVEN		
	Data bit	8 bit		
	Stop bit	1 or 2 bit		
	Baud rate	2400, 4800, 9600, 19200, 38400, 57600, 115200 bps		
Malfunction vibration		10~55 Hz 20m / s <sup>2</sup> , for 10 mins. each in X, Y and Z directions.		
Vibration resistance		10~55 Hz 20m / s <sup>2</sup> , for 2 hrs. each in X, Y and Z directions.		
Malfunction shock		100m / s <sup>2</sup> , 3 times each in X, Y and Z directions.		
Shock resistance		300m / s <sup>2</sup> , 3 times each in X, Y and Z directions.		
Operating environment Temperature/ Humidity		0 ~ 50°C (in the case of no freezing or condensation) / 20% ~ 90% RH		
Storage environment Temperature		-25 ~ 65°C (in the case of no freezing or condensation)		
Dimension (mm)		W26 x H81 x D90	W40 x H107 x D43	
Weight		Appox.90g	Appox.105g	

# Oder Information

Block means optional functions with additional charge

	Output 1	Output 2	Alarm	TRS	Remote	COMM	Input type	Power
<b>Model</b>	1	0	1	0	0	0	01	A
<b>Plug-in-out terminal FE250</b>	0 None 1 Relay 2 Voltage Pulse (SSR Drive) 3 4-20mA 4 0-20mA A 0-5V B 0-10V C 1-5V D 2-10V	0 None 1 Relay 2 Voltage Pulse (SSR Drive) 3 4-20mA 4 0-20mA A 0-5V B 0-10V C 1-5V D 2-10V	0 None 1 1 Set 2 2 Sets A HBA B HBA+AL2	0 None 1 4-20mA 2 0-20mA A 0-5V B 0-10V C 1-5V D 2-10V	0 None 1 4-20mA 2 0-20mA A 0-5V B 0-10V C 1-5V D 2-10V	0 None 3 TTL B RS-485 (OLD FE) C RS-485	See input type table code	A AC 85-265V D DC 24V
<b>Fixed terminal FE251 FE300</b>								

## Input Type Table

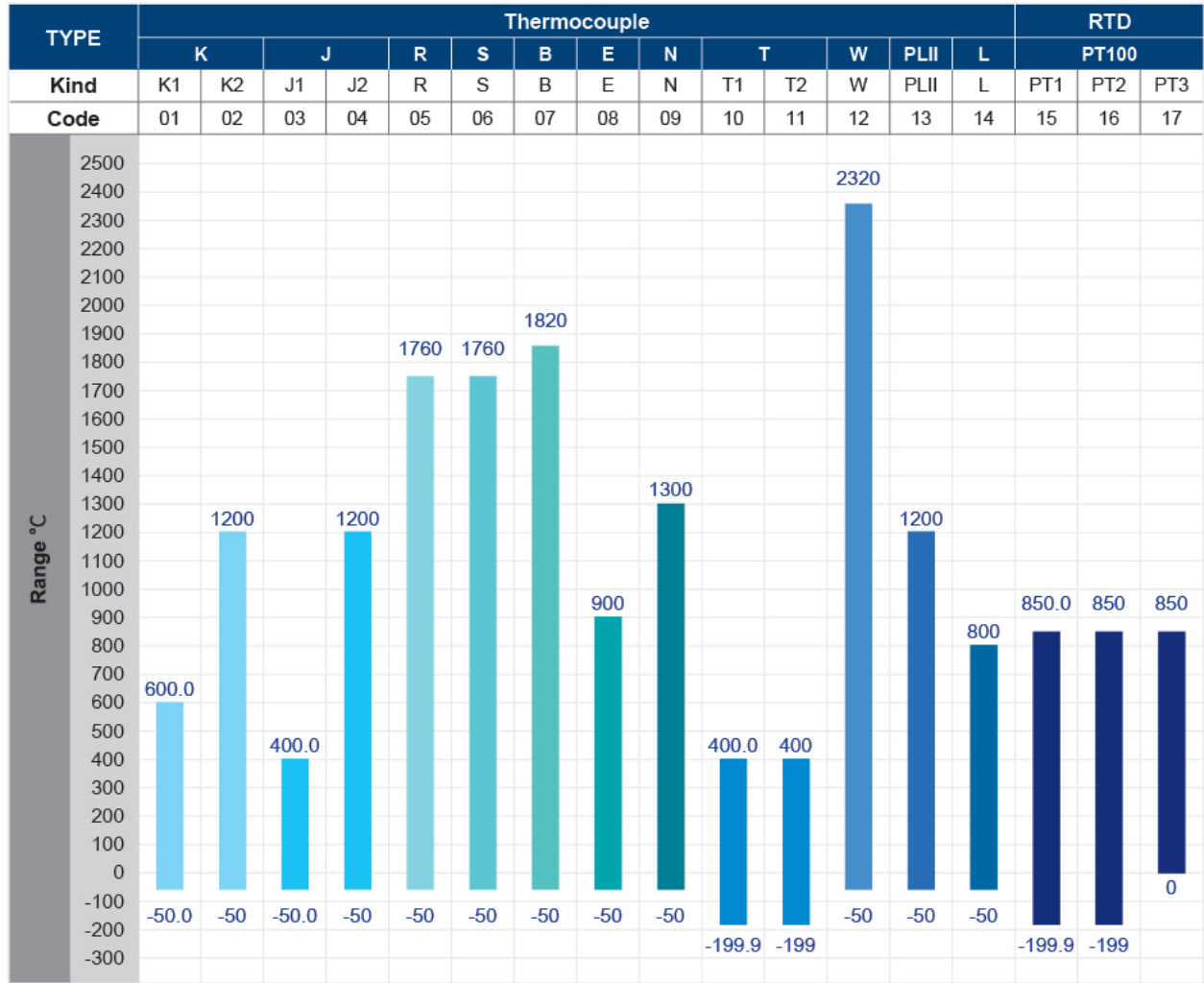

TYPE	LINEAR											
	AN1	AN2				AN3	AN4					
Code	18	19	20	21	22	23	24	25	26	27	28	29
Range	0~25mV	0~50mV	0~20mA	0~1V	0~2V	0~5V	0~10V	0~70mV	4~20mA	10~50mV	1~5V	2~10V

4 kinds of choices: -1999~9999 -199.9~999.9 -19.99~99.99 -1.999~9.999



- Before operating this product, read the instruction manual carefully to avoid incorrect operation.
- This product is intended for use with industrial machines, test and measuring equipment.
- It is not design for use with medical equipment.
- If it is possible that an accident may occur as a result of the failure of the product or some other abnormality, an appropriate independent protection device must be installed.



**TAIWAN INSTRUMENT & CONTROL CO., LTD**  
Subject to change without notice.  
All Rights Reserved, Copyright © 2020, TAIE

